

LS60

YALITIMLI SÜRME SİSTEMİ
THERMAL SLIDING SYSTEM

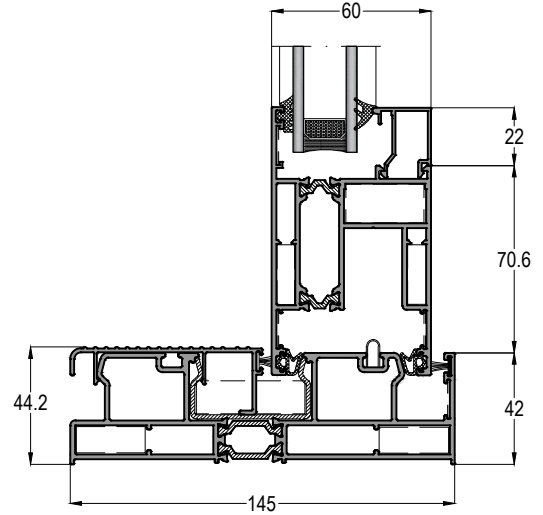

KASA GENİŞLİĞİ	: 136mm - 145mm - 221mm
Frame Width	
KANAT DERİNLİĞİ	: 60mm
Sash Depth	
SİSTEM ET KALINLIĞI	: 1,4 mm - 1,8 mm
System Wall Thickness	
ISI BARIYERİ	: Kasa 24mm - Kanat 14,8mm
Insulation Barrier	
CAM KALINLIĞI	: 10mm - 46mm
Glass Thickness	
KANAT TAŞIMA KAPASİTESİ	: 300kg - 400kg
Sash Carrying Capacity	
MAX. KANAT ENİ	: 720mm - 3235mm
Max. Sash Width	
MAX. KANAT YÜKSEKLİĞİ	: 1200mm - 2700mm
Max. Sash Height	

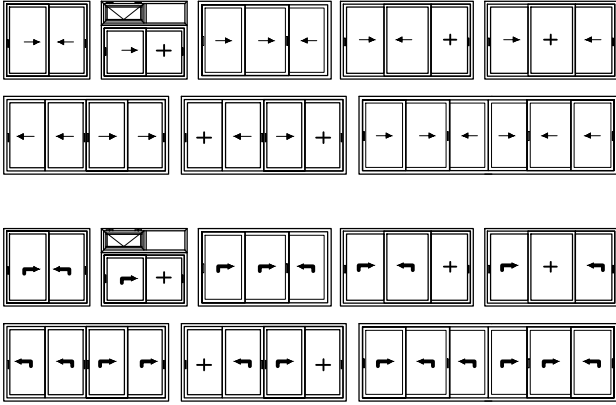
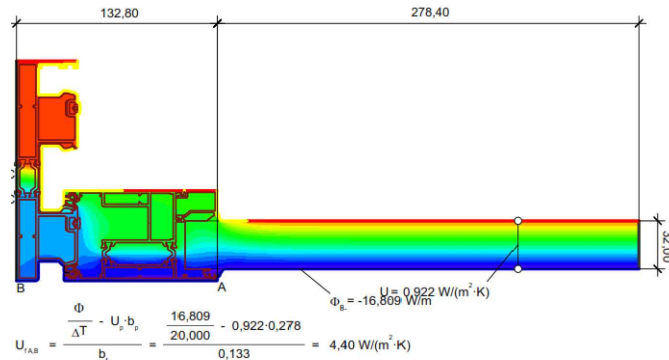



LS60

YALITIMLI KALDIR-SÜR SİSTEM
THERMAL LIFT&SLIDE SYSTEM





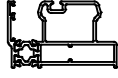
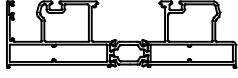
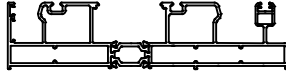
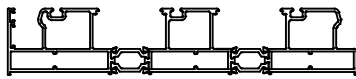
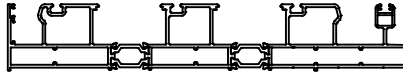
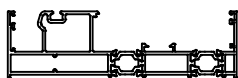
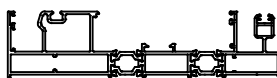
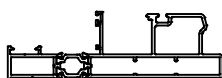
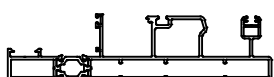





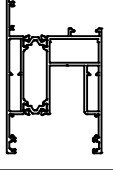

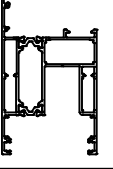

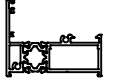
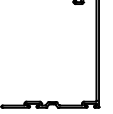
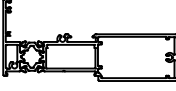
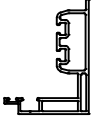
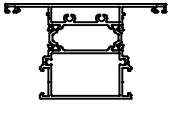

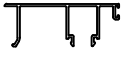
ASISTAL

PROFİL VE AKSESUAR LİSTELERİ
PROFILE & ACCESSORIES LIST

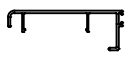

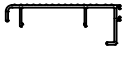







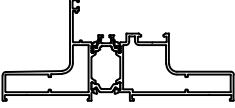

PROFİL LİSTESİ - PROFILES LIST

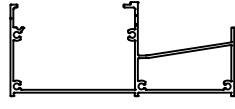
LS60 01			LS60 02		
KASA PROFİLİ FRAME PROFILE	AĞIRLIK / Weight 1,591 kg/mt		KASA PROFİLİ FRAME PROFILE	AĞIRLIK / Weight 2,822 kg/mt	
LS60 102					
2 Lİ SİNEKLİKLİ KASA PROFİLİ FLY SCREEN FRAME PROFILE	AĞIRLIK / Weight 3,396 kg/mt				
LS60 03					
3 LÜ KASA PROFİLİ FRAME PROFILE	AĞIRLIK / Weight 4,210 kg/mt				
LS60 103					
3 LÜ SİNEKLİKLİ KASA PROFİLİ FLY SCREEN FRAME PROFILE	AĞIRLIK / Weight 4,786 kg/mt				
LS60 04			NOT: LS60 04 KASA, CAM KALINLIĞI 24mm DEN FAZLA OLAN CAMLARIN MONTAJI İÇİN UYGUN DEĞİLDİR LS60 04 CASE, NOT SUITABLE FOR INSTALLATION FOR GLASSES WITH GLASS THICKNESS MORE THAN 24mm		
DIŞTAN SABİTLİ KASA PROFİLİ MONORAIL FRAME PROFILE	AĞIRLIK / Weight 2,764 kg/mt				
LS60 104			NOT: LS60 104 KASA, CAM KALINLIĞI 24mm DEN FAZLA OLAN CAMLARIN MONTAJI İÇİN UYGUN DEĞİLDİR LS60 104 CASE, NOT SUITABLE FOR INSTALLATION FOR GLASSES WITH GLASS THICKNESS MORE THAN 24mm		
DIŞTAN SABİTLİ SİNEKLİK KASA PROFİLİ MONORAIL FRAME PROFILE	AĞIRLIK / Weight 3,223 kg/mt				
LS60 118					
İÇTEN SABİTLİ KASA PROFİLİ MONORAIL FRAME PROFILE	AĞIRLIK / Weight 2,345 kg/mt				
LS60 119					
İÇTEN SABİT SİNEKLİKLİ KASA PROFİLİ MONORAIL FRAME PROFILE	AĞIRLIK / Weight 2,895 kg/mt				
LS60 05 - 1,4mm					
KASA PROFİLİ-1,4mm FRAME PROFILE	AĞIRLIK / Weight 2,448 kg/mt				
LS60 05F - 1,4mm					
SİNEKLİKLİ KASA PROFİLİ-1,4mm FLY SCREEN FRAME PROFILE	AĞIRLIK / Weight 2,952 kg/mt				

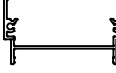

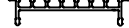
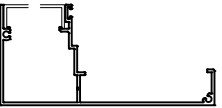













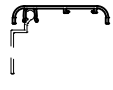

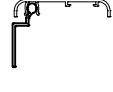
PROFİL LİSTESİ - PROFILES LIST

LS60 11	Jx cm ⁴ 43,22	Jy cm ⁴ 49,37		LS60-40	
KANAT PROFİLİ SASH PROFILE	AĞIRLIK / Weight 2,312 kg/mt			KAPAK PROFİLİ COVER PROFILE	
LS60 12- 1,4mm	Jx cm ⁴ 36,03	Jy cm ⁴ 47,29		LS60 41	
KANAT PROFİLİ-1,4mm SASH PROFILE	AĞIRLIK / Weight 2,080 kg/mt			ADAPTÖR PROFİLİ ADAPTER PROFILE	
LS60 112	Jx cm ⁴ 19,15	Jy cm ⁴ 5,20		LS60 42	
DAR KANAT PROFİLİ SASH PROFILE	AĞIRLIK / Weight 1,244 kg/mt			KENET PROFİLİ CENTRAL LOCKING PROFILE	
LS60 113	Jx cm ⁴ 99,15	Jy cm ⁴ 9,16		LS60 43	
DAR KANAT PROFİLİ SASH PROFILE	AĞIRLIK / Weight 1,933 kg/mt			3'LÜ KANAT ADAPTÖR PROFİLİ ADAPTER PROFILE	
TH60 23				LS60 44	
ORTA KAYIT PROFİLİ TRANSOM-MULLION PROFILE	AĞIRLIK / Weight 2,128 kg/mt			İSPANYOLET KİLİTLEME ADAPTÖR PROFİLİ MULTI POINT LOCK ADAPTER	
LS60 31				LS60 45	
KAPAK PROFİLİ COVER PROFILE	AĞIRLIK / Weight 0,686 kg/mt			KENET PROFİLİ CENTRAL LOCKING PROFILE	
LS60 32				LS60 46	
DEKORATİF KAPAK PROFİLİ DECORATIVE COVER PROFILE	AĞIRLIK / Weight 0,710 kg/mt			YAN KAPAK PROFİLİ SIDE COVER PROFILE	
LS60 33				LS60 71	
KAPAK PROFİLİ COVER PROFILE	AĞIRLIK / Weight 0,523 kg/mt			KULP PROFİLİ HANDLE PROFILE	
LS60 34				LS60 72	
DEKORATİF KAPAK PROFİLİ DECORATIVE COVER PROFILE	AĞIRLIK / Weight 0,545 kg/mt			KULP KAPAK PROFİLİ HANDLE COVER PROFILE	
LS60 35				12-71	
KANAT SABİTLEME PROFİLİ SASH FIXING PROFILE	AĞIRLIK / Weight 0,670 kg/mt			ADAPTÖR PROFİLİ ADAPTER PROFILE	

PROFİL LİSTESİ - PROFILES LIST

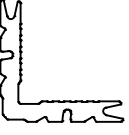
12-72			13-09986		
ADAPTÖR PROFİLİ ADAPTER PROFILE	AĞIRLIK / Weight 0,285 kg/mt		SİNEKLİK RAY PROFİLİ FLYSCREEN RAIL PROFILE	AĞIRLIK / Weight 0,740 kg/mt	
LS60 62			SL34T-52		
TH62 SİSTEM GEÇİŞ KASA PROFİLİ FRAME PROFILE FOR TH62	AĞIRLIK / Weight 2,418 kg/mt		DAR SİNEKLİK KANAT PROFİLİ FLYSCREEN SASH PROFILE	AĞIRLIK / Weight 0,469 kg/mt	
DR-001			1042		
DRENAJ KANAL PROFİLİ WATER DRAINAGE PROFILE	AĞIRLIK / Weight 1,998 kg/mt		SİNEKLİK RAY PROFİLİ FLYSCREEN RAIL PROFILE	AĞIRLIK / Weight 0,553 kg/mt	
DR-002		 MEKANİK İŞLEMLE DELME YAPILMIŞTIR DRILLING WAS DONE BY MECHANICAL PROCESS	SL-1515		
DRENAJ KANAL UZATMA PROFİLİ WATER DRAINAGE ADDITIONAL PROFILE	AĞIRLIK / Weight 0,918 kg/mt		KASA MONTAJ PROFİLİ FRAME ASSEMBLY PROFILE	AĞIRLIK / Weight 0,092 kg/mt	
DR-003		 MEKANİK İŞLEMLE DELME YAPILMIŞTIR DRILLING WAS DONE BY MECHANICAL PROCESS			
DRENAJ KANAL KAPAK PROFİLİ WATER DRAINAGE COVER PROFILE	AĞIRLIK / Weight 0,724 kg/mt				
DR-004					
DRENAJ KANAL PROFİLİ WATER DRAINAGE PROFILE	AĞIRLIK / Weight 1,540 kg/mt				
DR-005		 MEKANİK İŞLEMLE DELME YAPILMIŞTIR DRILLING WAS DONE BY MECHANICAL PROCESS			
DRENAJ KANAL KAPAK PROFİLİ WATER DRAINAGE COVER PROFILE	AĞIRLIK / Weight 0,308 kg/mt				
LS60 61					
SİNEKLİK RAY PROFİLİ FLYSCREEN RAIL PROFILE	AĞIRLIK / Weight 0,391 kg/mt				
15-304216-09					
SİNEKLİK KANAT PROFİLİ FLYSCREEN SASH PROFILE	AĞIRLIK / Weight 0,352 kg/mt				
15-306317-11					
SİNEKLİK KANAT PROFİLİ FLYSCREEN SASH PROFILE	AĞIRLIK / Weight 0,561 kg/mt				

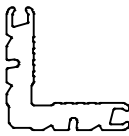

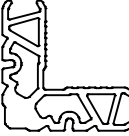













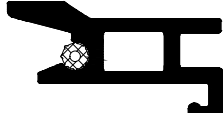

PROFİL LİSTESİ - PROFILES LIST

11-004			11-032		
CAM ÇİTASI-4 mm GLAZING BEAD PROFILE	AĞIRLIK / Weight 0,181 kg/mt		CAM ÇİTASI-32 mm GLAZING BEAD PROFILE	AĞIRLIK / Weight 0,315 kg/mt	
11-106			11-035		
CAM ÇİTASI-6 mm GLAZING BEAD PROFILE	AĞIRLIK / Weight 0,200 kg/mt		CAM ÇİTASI-35 mm GLAZING BEAD PROFILE	AĞIRLIK / Weight 0,323 kg/mt	
11-010			11-038		
CAM ÇİTASI-10 mm GLAZING BEAD PROFILE	AĞIRLIK / Weight 0,233 kg/mt		CAM ÇİTASI-38 mm GLAZING BEAD PROFILE	AĞIRLIK / Weight 0,334 kg/mt	
11-015			12-52		
CAM ÇİTASI-15 mm GLAZING BEAD PROFILE	AĞIRLIK / Weight 0,244 kg/mt		PERVAZ PROFİLİ BORDER PROFILE	AĞIRLIK / Weight 0,279 kg/mt	
11-017			12-53		
CAM ÇİTASI-17 mm GLAZING BEAD PROFILE	AĞIRLIK / Weight 0,250 kg/mt		PERVAZ MONTAJ PROFİLİ BORDER FIXING PROFILE	AĞIRLIK / Weight 0,177 kg/mt	
11-020			12-54		
CAM ÇİTASI-20 mm GLAZING BEAD PROFILE	AĞIRLIK / Weight 0,276 kg/mt		PERVAZ PROFİLİ BORDER PROFILE	AĞIRLIK / Weight 0,326 kg/mt	
11-022			12-57		
CAM ÇİTASI-22 mm GLAZING BEAD PROFILE	AĞIRLIK / Weight 0,282 kg/mt		PERVAZ PROFİLİ BORDER PROFILE	AĞIRLIK / Weight 0,358 kg/mt	
11-026			10-010106-00		
CAM ÇİTASI-26 mm GLAZING BEAD PROFILE	AĞIRLIK / Weight 0,296 kg/mt		KÖŞE TAKOZU-10,6 mm CORNER JOINT	AĞIRLIK / Weight 2,653 kg/mt	
11-028			10-010140-00		
CAM ÇİTASI-28 mm GLAZING BEAD PROFILE	AĞIRLIK / Weight 0,302 kg/mt		KÖŞE TAKOZU-14,2 mm CORNER JOINT	AĞIRLIK / Weight 3,582 kg/mt	
11-030			10-010225-00		
CAM ÇİTASI-30 mm GLAZING BEAD PROFILE	AĞIRLIK / Weight 0,308 kg/mt		KÖŞE TAKOZU-22,5 mm CORNER JOINT	AĞIRLIK / Weight 3,566 kg/mt	





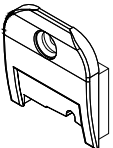

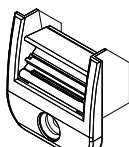
Profil ağırlıklarımız teorik olup; teslim anındaki tartımız geçerlidir.

Profile weights are theoretical and the weight at the time of delivery is valid.

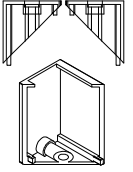
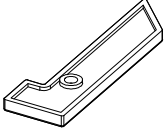
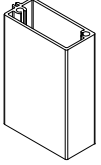
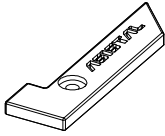
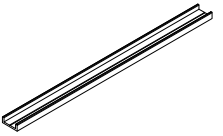
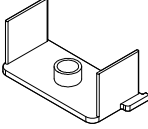
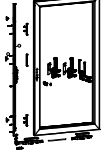
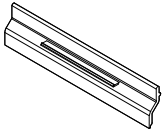
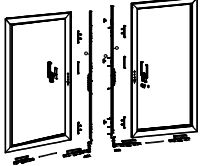
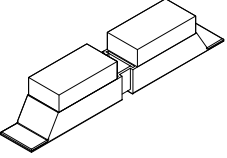

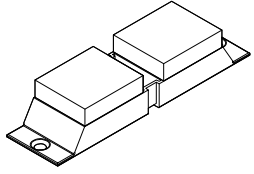
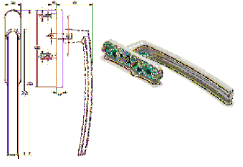
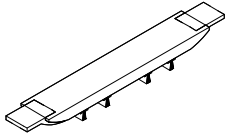
AKSESUAR LİSTESİ - ACCESSORIES LIST

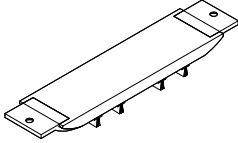
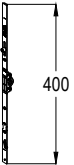
EP1-01			EP5-01		
DIŞ CAM FİTİLİ - 3,5 mm <i>OUTER GLAZING GASKET</i>	KOLİ MİKTARI/Package 240 mt / 15 kg		KANAL FİTİLİ <i>ADAPTER GASKET</i>	KOLİ MİKTARI/Package mt / koli	
EP2-01			KF 67-600		
İÇ CAM FİTİLİ - 3 mm <i>INNER GLAZING GASKET</i>	KOLİ MİKTARI/Package 440 mt / 15 kg		FİRÇA FİTİL-6mm <i>BRUSH GASKET</i>	KOLİ MİKTARI/Package 1300 mt / koli	
EP2-02			KF 67-700		
İÇ CAM FİTİLİ - 4 mm <i>INNER GLAZING GASKET</i>	KOLİ MİKTARI/Package 300 mt / 15 kg		FİRÇA FİTİL-7mm <i>BRUSH GASKET</i>	KOLİ MİKTARI/Package 1100 mt / koli	
EP2-03			KF 67-1000		
İÇ CAM FİTİLİ - 5 mm <i>INNER GLAZING GASKET</i>	KOLİ MİKTARI/Package 250 mt / 15 kg		FİRÇA FİTİL-10mm <i>BRUSH GASKET</i>	KOLİ MİKTARI/Package 600 mt / koli	
EP60-03			MO60-10		
KANAT ÜST FİTİLİ <i>SASH GASKET</i>	KOLİ MİKTARI/Package 330 mt / 15 kg		KENET PVC PROFİL <i>CENTRAL LOCKING PVC PROFILE</i>	KOLİ MİKTARI/Package 6 mt / Adet	
EP60-R04			MO60-11		
KENET FİTİLİ <i>CENTRAL LOCKING GASKET</i>	KOLİ MİKTARI/Package 300 mt / 15 kg		KENET PVC PROFİL <i>CENTRAL LOCKING PVC PROFILE</i>	KOLİ MİKTARI/Package 6 mt / Adet	
EP60-05			MO60-07		
KANAT FİTİLİ <i>SASH GASKET</i>	KOLİ MİKTARI/Package 300 mt / 15 kg		KASA KANAL PLASTİĞİ LS60 04 KASA İÇİN <i>PVC PROFILE FOR LS60 04</i>	KOLİ MİKTARI/Package 6 mt / Adet	
EP38-02			MO60-08		
KASA KANAL FİTİLİ <i>FRAME GASKET</i>	KOLİ MİKTARI/Package 535 mt / 15 kg		KASA KANAL PLASTİĞİ LS60 02 ve LS60 03 İÇİN <i>PVC PROFILE FOR LS60 02 & LS60 03</i>	KOLİ MİKTARI/Package 6 mt / Adet	
INT2-02			MO60-01		
KANAL FİTİLİ <i>ADAPTER GASKET</i>	KOLİ MİKTARI/Package 350 mt / 15 kg		KENET KAPAĞI-ALT <i>INTERLOCK PROFILE-BOTTOM</i>	KOLİ MİKTARI/Package Adet / Piece	
EP38-03			MO60-02		
SABİT ÇITA FİTİLİ <i>FIXED FRAME GASKET</i>	KOLİ MİKTARI/Package 145 mt / 13 kg		KENET KAPAĞI-ÜST <i>INTERLOCK PROFILE-TOP</i>	KOLİ MİKTARI/Package Adet / Piece	

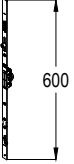

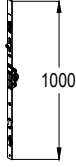
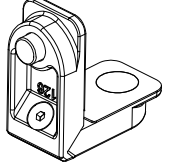
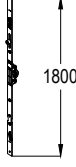
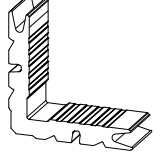
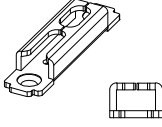
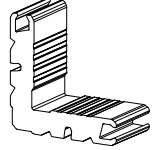
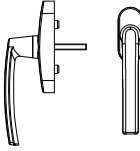
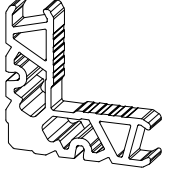
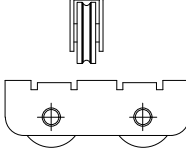

AKSESUAR LİSTESİ - ACCESSORIES LIST

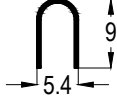
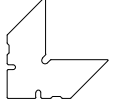
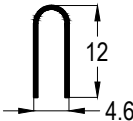
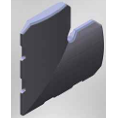
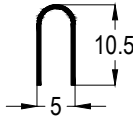
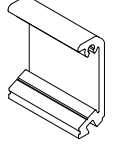
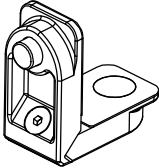
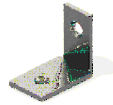
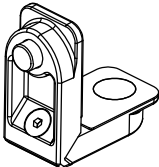
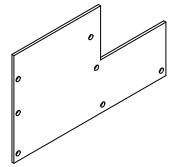
FLY-KP01			MO70-INT 01		
SİNEKLİK 90 KAPAĞI FLYSCREEN CAP	KOLİ MİKTARI/Package Adet / Piece		90°DAR KENET KAPAK TAKIMI - LS7013 COVER	KOLİ MİKTARI/Package Takım / Set	
MO60-03			LS60-DB 3560		
MO60-10 İÇİN KAPAK-ALT COVER FOR MO60-10-BOTTOM	KOLİ MİKTARI/Package Adet / Piece		KANAT SABİTLEME PARÇASI SASH FIXING	KOLİ MİKTARI/Package Adet / Piece	
MO60-04			ASI-SL1520		
MO60-10 İÇİN KAPAK-ÜST COVER FOR MO60-10-TOP	KOLİ MİKTARI/Package Adet / Piece		KASA MONTAJ PARÇASI FRAME ASSEMBLY PART	KOLİ MİKTARI/Package Adet / Piece	
MO60-12			LS60-MEK1		
4 LÜ KANAT KİLİTLEME ADAPTÖR KAPAĞI MEETING STILE CAP	KOLİ MİKTARI/Package Adet / Piece		300 kg KAPASİTELİ KALDIR-SÜR MEKANİZMA LIFT & SLIDE MECHANISM	KOLİ MİKTARI/Package Takım / Set	
MO60-13			LS60-MEK1D		
KANAT DENGELEME PLASTİĞİ SASH STABILIZATION SPACER	KOLİ MİKTARI/Package Adet / Piece		300 kg KAPASİTELİ 4'LÜ KANAT MEKANİZMA LIFT & SLIDE MECHANISM	KOLİ MİKTARI/Package Takım / Set	
MO60-05D			ASI-LS-H01		
HAVA KESİCİ-ALT LS60 04 KASA İÇİN CENTRAL SEALING-BOTTOM FOR LS60 04	KOLİ MİKTARI/Package Adet / Piece		KALDIR-SÜR KOLU LIFT&SLIDE HANDLE	KOLİ MİKTARI/Package Takım / Set	
MO60-05G			ASI-LS-H01A		
HAVA KESİCİ-ALT CENTRAL SEALING-BOTTOM	KOLİ MİKTARI/Package Adet / Piece		KALDIR-SÜR KOLU TEKLİ LIFT&SLIDE HANDLE SINGLE	KOLİ MİKTARI/Package Adet / Piece	
MO60-06D			ASI-LS-H02		
HAVA KESİCİ-ÜST LS60 04 KASA İÇİN CENTRAL SEALING-TOP FOR LS60 04	KOLİ MİKTARI/Package Adet / Piece		KALDIR-SÜR KOLU KİLİTLİ LIFT&SLIDE HANDLE LOCK	KOLİ MİKTARI/Package Takım / Set	
MO60-06G			ASI-ISP15.0		
HAVA KESİCİ-ÜST CENTRAL SEALING-TOP	KOLİ MİKTARI/Package Adet / Piece		İSPANYOLET KİLİTLEME (400mm) - 15.5 AKS MULTI POINT LOCK	KOLİ MİKTARI/Package Adet / Piece	
MO60-19			ASI-ISP15.1		
KOL PROFİL KAPAĞI HANDLE PROFILE CAP	KOLİ MİKTARI/Package alt-üst takım / set		İSPANYOLET KİLİTLEME (600mm) - 15.5 AKS MULTI POINT LOCK	KOLİ MİKTARI/Package Adet / Piece	

AKSESUAR LİSTESİ - ACCESSORIES LIST

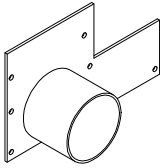
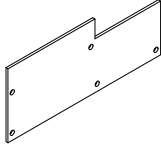
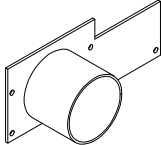
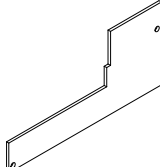
ASI-ISP15.2			ASI-PB 1126		
İSPANYOLET KİLİTLEME (1000mm)-15.5 AKS <i>MULTI POINT LOCK</i>	KOLİ MİKTARI/Package Adet / Piece		PİMLİ KÖŞE BAĞLANTI <i>CORNER JOINT</i>	KOLİ MİKTARI/Package 11 x 26 mm	
ASI-ISP15.3			ASI-KT 1126		
İSPANYOLET KİLİTLEME (1800mm) - 15.5 AKS <i>MULTI POINT LOCK</i>	KOLİ MİKTARI/Package Adet / Piece		KÖŞE TAKOZU <i>CORNER JOINT</i>	KOLİ MİKTARI/Package Adet / Piece	
ASI-ISP K03			ASI-KT 1429		
İSPANYOLET KİLİT KARŞILIK <i>MULTI POINT LOCK STRIKER</i>	KOLİ MİKTARI/Package Adet / Piece		KÖŞE TAKOZU <i>CORNER JOINT</i>	KOLİ MİKTARI/Package Adet / Piece	
ASI-WH 002			ASI-KT 2307		
İSPANYOLET KİLİTLEME KOL <i>MULTI POINT LOCK HANDLE</i>	KOLİ MİKTARI/Package Adet / Piece		KÖŞE TAKOZU <i>CORNER JOINT</i>	KOLİ MİKTARI/Package Adet / Piece	
ASI-SR 04			ASI-SB 19.1		
NORMAL SÜRME RULMAN (U TİPİ RAY) <i>NORMAL SLIDING ROLLER FOR RAIL TYPE - U</i>	KOLİ MİKTARI/Package Adet / Piece		KÖŞE GÖNYESİ <i>CORNER ALIGNMENT</i>	KOLİ MİKTARI/Package 1000 Adet / Piece	
ASI-INR 01 Sineklik için <i>for Flyscreen Sliding</i>			ASI-SB 34		
ÇELİK RAY <i>STEEL RAIL</i>	KOLİ MİKTARI/Package 6 mt / Adet		KÖŞE GÖNYESİ <i>CORNER ALIGNMENT</i>	KOLİ MİKTARI/Package 1000 Adet / Piece	
ASI-INR 02 Normal Sürme için <i>for Normal Sliding</i>			EM 12-54		
ÇELİK RAY <i>STEEL RAIL_LS60-SD</i>	KOLİ MİKTARI/Package 6 mt / Adet		KÖŞE GÖNYESİ <i>CORNER ALIGNMENT</i>	KOLİ MİKTARI/Package 1000 Adet / Piece	
ASI-INR 03 Kaldır-Sür Sürme için <i>for Lift&Sliding</i>			ASI-DB 9143		
ÇELİK RAY <i>STEEL RAIL_LS60-LSDR</i>	KOLİ MİKTARI/Package 6 mt / Adet		DİK BAĞLANTI <i>T JOINT</i>	KOLİ MİKTARI/Package Adet / Piece	
ASI-PB 1119			ASI-P 100.1		
KÖŞE BAĞLANTI <i>CORNER JOINT</i>	KOLİ MİKTARI/Package 11 x 19 mm		DİK BAĞLANTI <i>T JOINT</i>	KOLİ MİKTARI/Package 250 Adet / Piece	
ASI-PB 1124 (MON / 0404)			DR-KAP 01		
KÖŞE BAĞLANTI <i>CORNER JOINT</i>	KOLİ MİKTARI/Package 11 x 24 mm		DRENAJ KANAL KAPAK <i>WATER DRAINAGE COVER</i>	KOLİ MİKTARI/Package Adet / Piece	

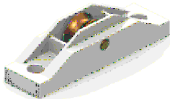
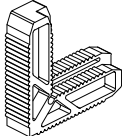
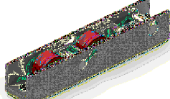
AKSESUAR LİSTESİ - ACCESSORIES LIST

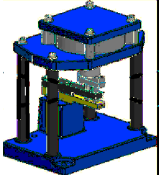
DR-KAP 02				
DRENAJ KANAL KAPAK <i>WATER DRAINAGE COVER</i>	KOLİ MİKTARI/Package Adet / Piece			
DR-KAP 03				
DRENAJ KANAL KAPAK <i>WATER DRAINAGE COVER</i>	KOLİ MİKTARI/Package Adet / Piece			
DR-KAP 04				
DRENAJ KANAL KAPAK <i>WATER DRAINAGE COVER</i>	KOLİ MİKTARI/Package Adet / Piece			
DR-KAP 05				
DRENAJ KANAL KAPAK <i>WATER DRAINAGE COVER</i>	KOLİ MİKTARI/Package Adet / Piece			
ASI-5025				
SİNEKLİK FİTİLİ <i>FLYSCREEN GASKET</i>	KOLİ MİKTARI/Package 100 mt			
ASI-BZ 5060				
SİNEKLİK KANAT RULMAN <i>FLYSCREEN SASH ROLLER</i>	KOLİ MİKTARI/Package Adet / Piece			
ASI-BZ 5007				
SİNEKLİK KÖŞE TAKOZU <i>FLYSCREEN CORNER JOINT</i>	KOLİ MİKTARI/Package Adet / Piece			
ASI-SR 02R				
AYARLI ÇİFTLİ RULMAN (SİNEKLİK İÇİN) <i>DOUBLE SLIDING ROLLER FOR FLY SCREEN</i>	KOLİ MİKTARI/Package Adet / Piece			
ASI-WDC 01				
YAĞMUR TAHLİYE KAPAĞI <i>WATER REJECT COVER</i>	KOLİ MİKTARI/Package Adet / Piece			
501 EKO PANÇ				
KÖŞE PİMLİ BAĞLANTI PANÇ MAKİNESİ <i>PUNCH MACHINE FOR CORNER JOINT WITH PIN</i>	KOLİ MİKTARI/Package Adet / Piece			

LS60

YALITIMLI KALDIR-SÜR SİSTEM
THERMAL LIFT&SLIDE SYSTEM

ASISTAL



PROFİL DETAYLARI
PROFILE DETAILS

LS60

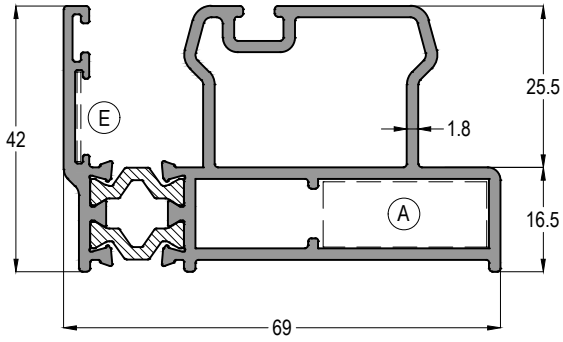

YALITIMLI KALDIR-SÜR SİSTEM
THERMAL LIFT&SLIDE SYSTEM

ASISTAL



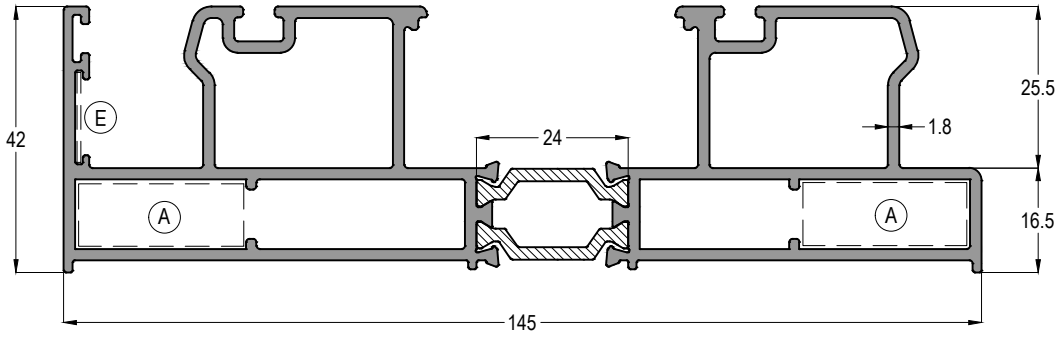

LS60 01		
 ASI-KT 1126 - ASI-PB 1126	 ASI-SB 19.1	AĞIRLIK / Weight
		1,591 kg/mt

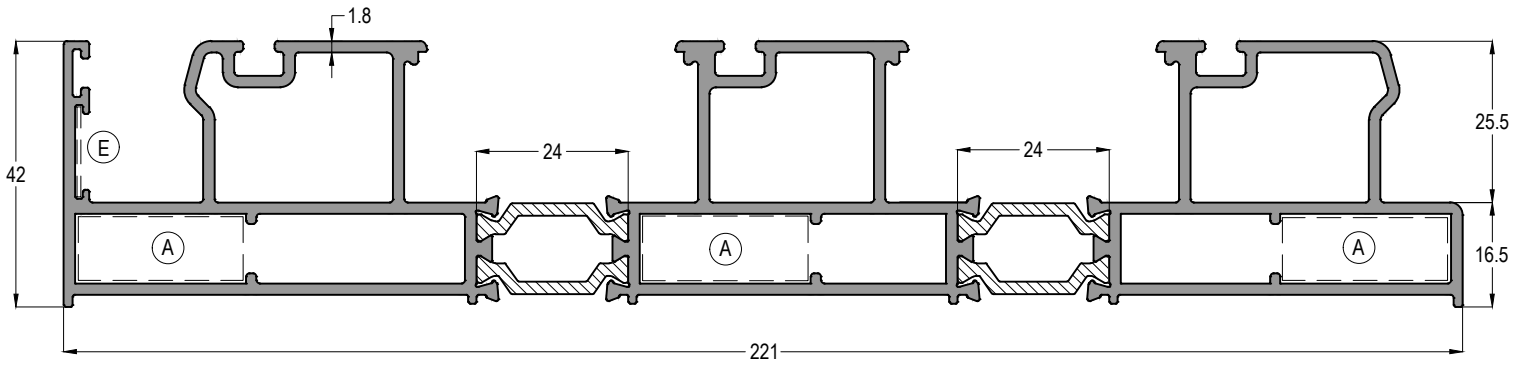

LS60 02		
 ASI-KT 1126 - ASI-PB 1126	 ASI-SB 19.1	AĞIRLIK / Weight
		2,822 kg/mt



LS60 03		
 ASI-KT 1126 - ASI-PB 1126	 ASI-SB 19.1	AĞIRLIK / Weight
		4,210 kg/mt

Profil ağırlıklarımız teorik olup; teslim anındaki tartımız geçerlidir.
Profile weights are theoretical and the weight at the time of delivery is valid.

LS60

YALITIMLI KALDIR-SÜR SİSTEM
THERMAL LIFT&SLIDE SYSTEM



ASISTAL

SİNEKLİKLİ KASALAR - 1,8mm

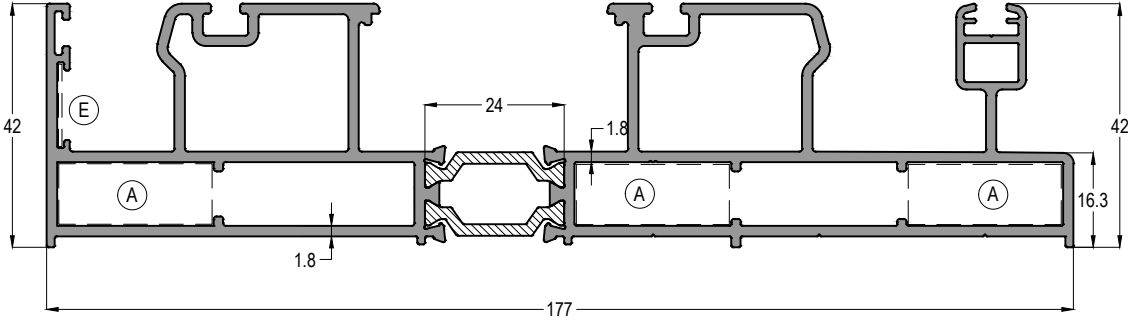
FRAMES with FLYSCREEN - 1,8mm



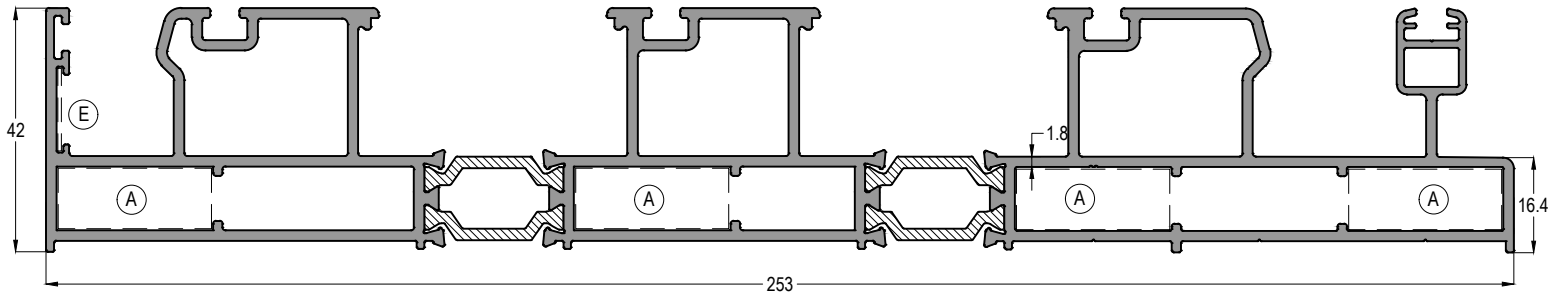

LS60 102

		AĞIRLIK / Weight
		3,396 kg/mt



LS60 103

		AĞIRLIK / Weight
		4,786 kg/mt

LS60

YALITIMLI KALDIR-SÜR SİSTEM
THERMAL LIFT&SLIDE SYSTEM

ASISTAL

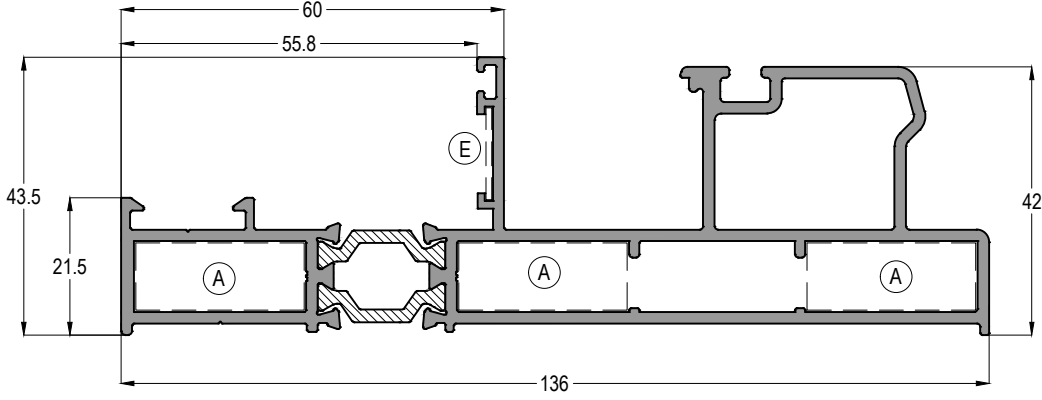

LS60 118



ASI-KT 1126 - ASI-PB 1126



ASI-SB 19.1

AĞIRLIK / Weight

2,345 kg/mt

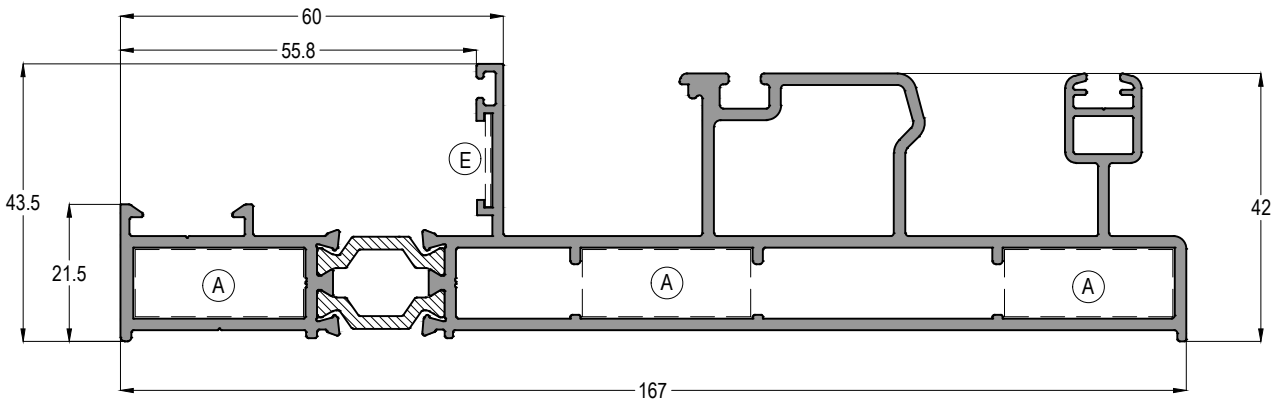

LS60 119



ASI-KT 1126 - ASI-PB 1126

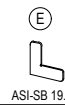

ASI-SB 19.1

AĞIRLIK / Weight

2,895 kg/mt

LS60

YALITIMLI KALDIR-SÜR SİSTEM
THERMAL LIFT&SLIDE SYSTEM

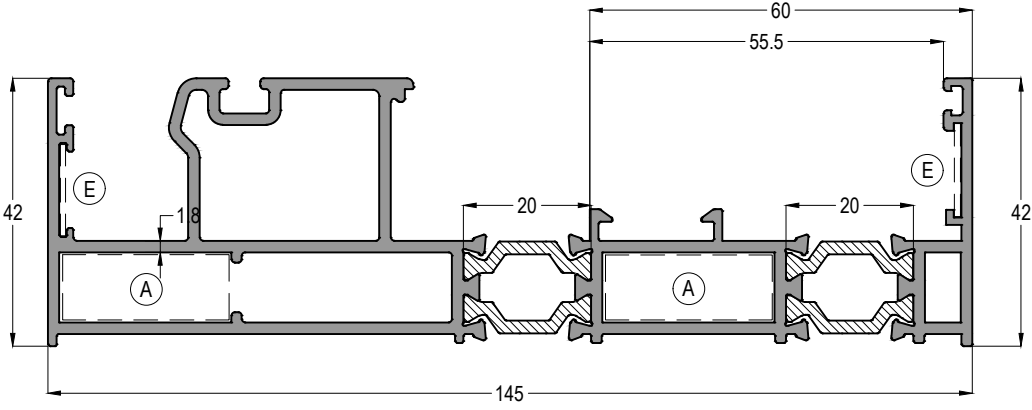

ASISTAL



NOT: LS60 04 KASA, CAM KALINLIĞI 24mm DEN FAZLA OLAN CAMLARIN MONTAJI İÇİN UYGUN DEĞİLDİR



*LS60 04 CASE, NOT SUITABLE FOR INSTALLATION
FOR GLASSES WITH GLASS THICKNESS MORE THAN 24mm*

LS60 04

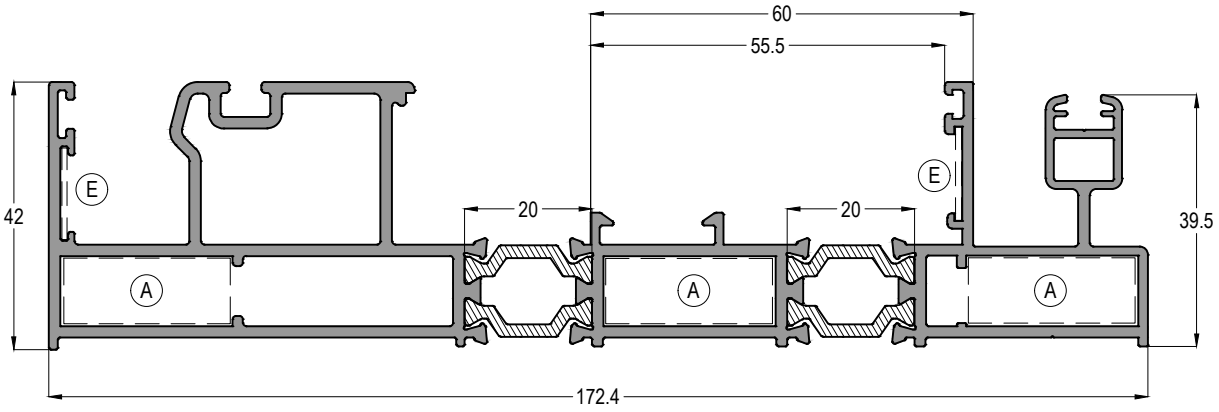
 ASI-KT 1126 ~ ASI-PB 1126	 ASI-SB 19.1	AĞIRLIK / Weight 2,764 kg/mt
--	--	---------------------------------



LS60 104

 ASI-KT 1126 ~ ASI-PB 1126	 ASI-SB 19.1	AĞIRLIK / Weight 3,223 kg/mt
--	--	---------------------------------

LS60 - 1,4mm

YALITIMLI KALDIR-SÜR SİSTEM
THERMAL LIFT&SLIDE SYSTEM

ASISTAL

KASALAR - 1,4mm

FRAMES - 1,4mm

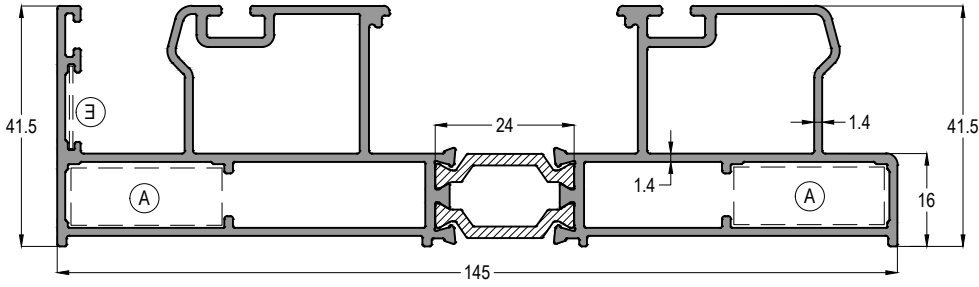

LS60 05



ASI-KT 1126 - ASI-PB 1126



ASI-SB 19.1

AĞIRLIK / Weight

2,448 kg/mt

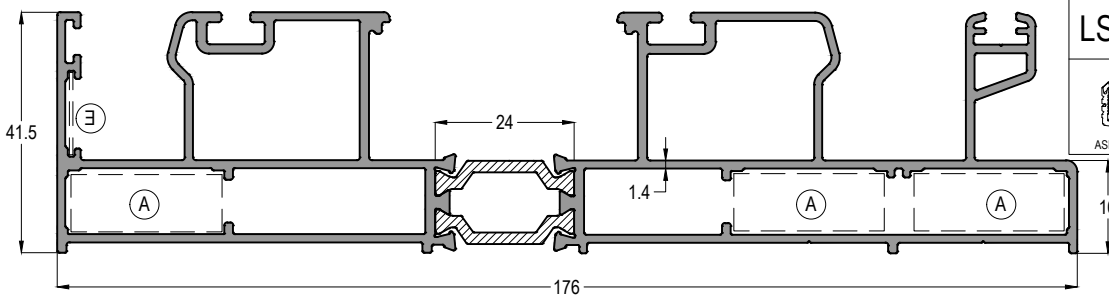

LS60 05F



ASI-KT 1126 - ASI-PB 1126



ASI-SB 19.1

AĞIRLIK / Weight

2,952 kg/mt

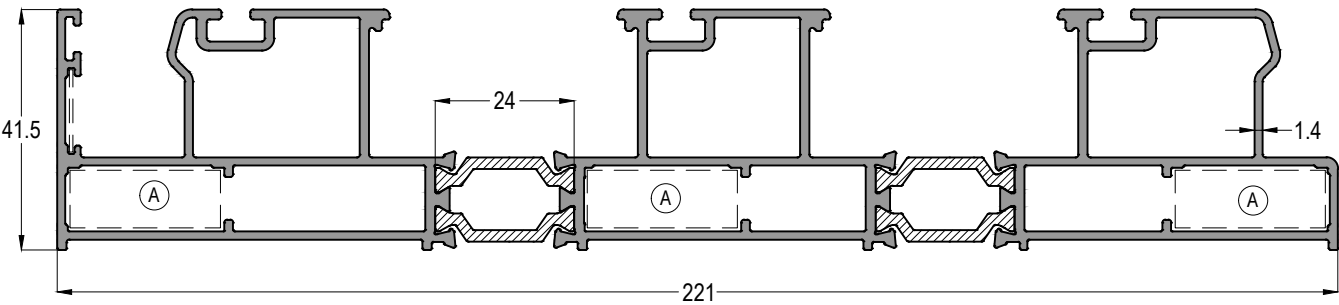

LS60 09



ASI-KT 1126 - ASI-PB 1126



ASI-SB 19.1

AĞIRLIK / Weight

3,698 kg/mt

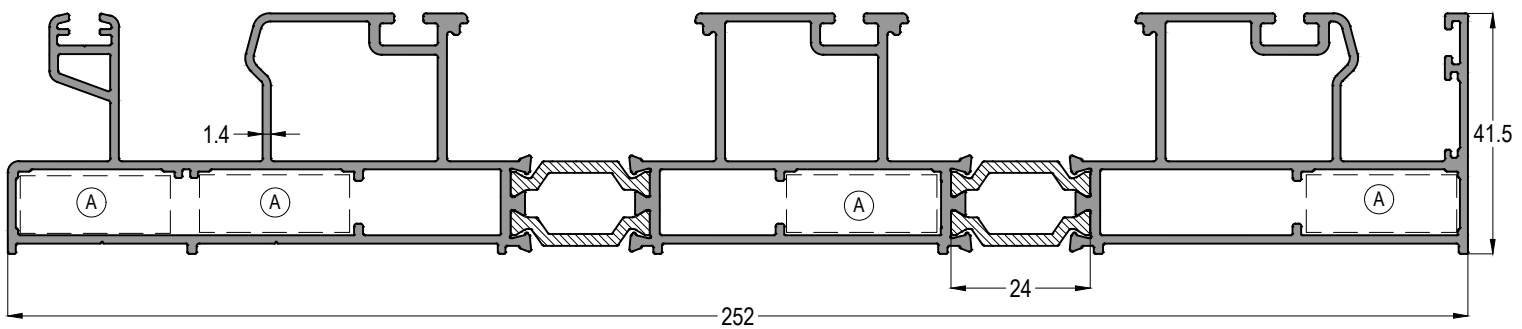

LS60 09F



ASI-KT 1126 - ASI-PB 1126



ASI-SB 19.1

AĞIRLIK / Weight

4,202 kg/mt



Profil ağırlıklarımız teorik olup, teslim anındaki tartımız geçerlidir.
Profile weights are theoretical and the weight at the time of delivery is valid.

LS60

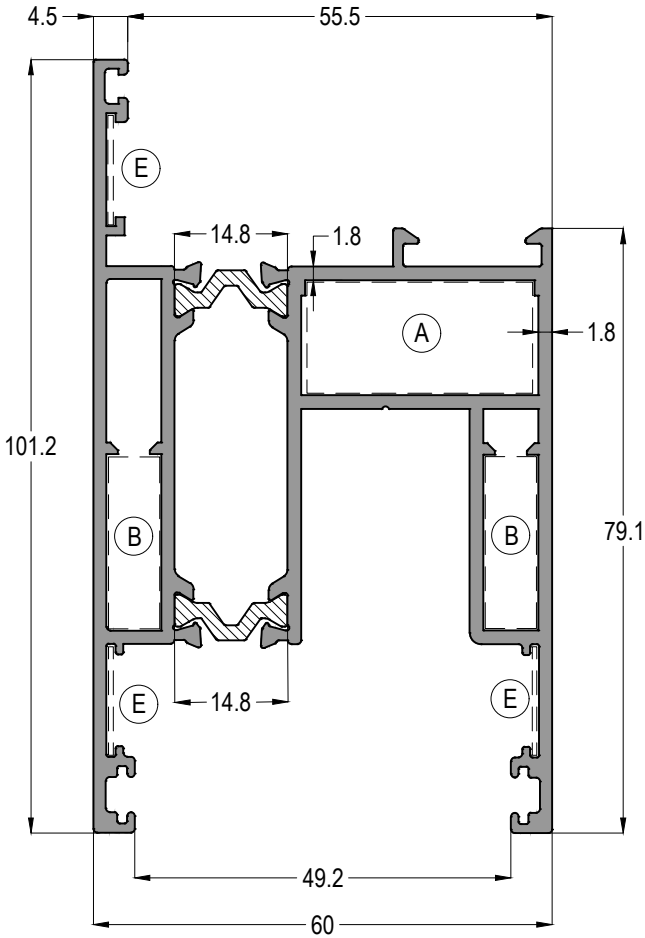

YALITIMLI KALDIR-SÜR SİSTEM
THERMAL LIFT&SLIDE SYSTEM

ASISTAL

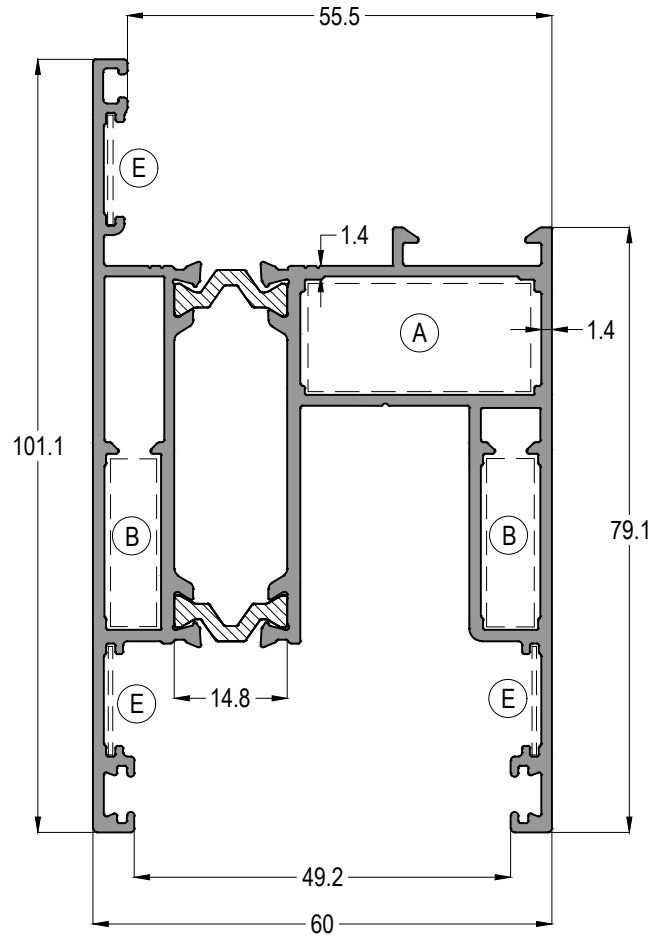

LS60 11			Jx cm ⁴	Jy cm ⁴
			43,22	49,37
			AĞIRLIK / Weight	
ASI-KT 1429	ASI-KT 2307	ASI-SB 19.1	2,312 kg/mt	



LS60 12 - 1,4mm			Jx cm ⁴	Jy cm ⁴
			36,03	47,29
			AĞIRLIK / Weight	
ASI-KT 1429	ASI-KT 2307	ASI-SB 19.1	2,080 kg/mt	

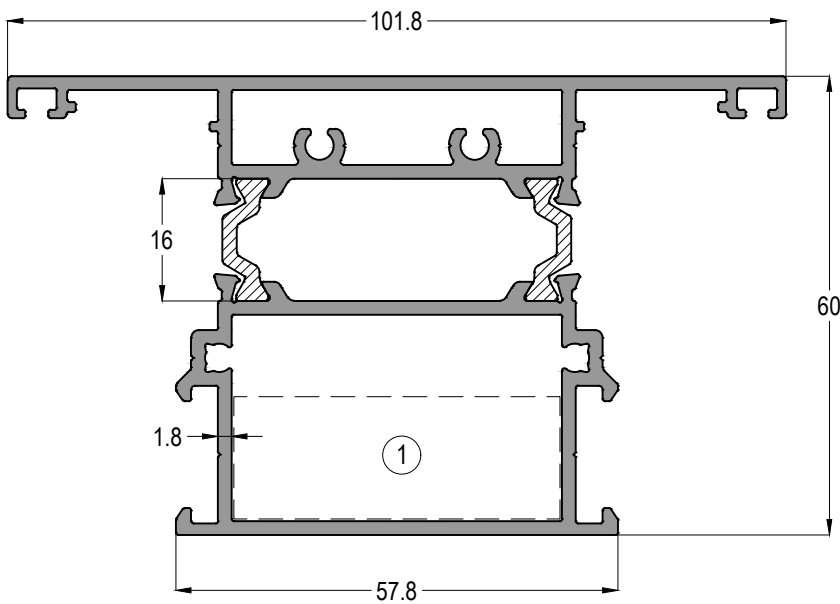



TH60 23		
	1	AĞIRLIK / Weight
ASI-DB 9143		2,128 kg/mt

LS60

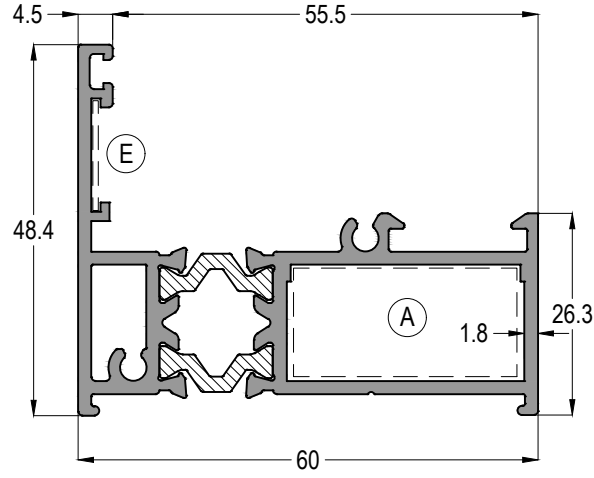

YALITIMLI KALDIR-SÜR SİSTEM
THERMAL LIFT&SLIDE SYSTEM

ASISTAL

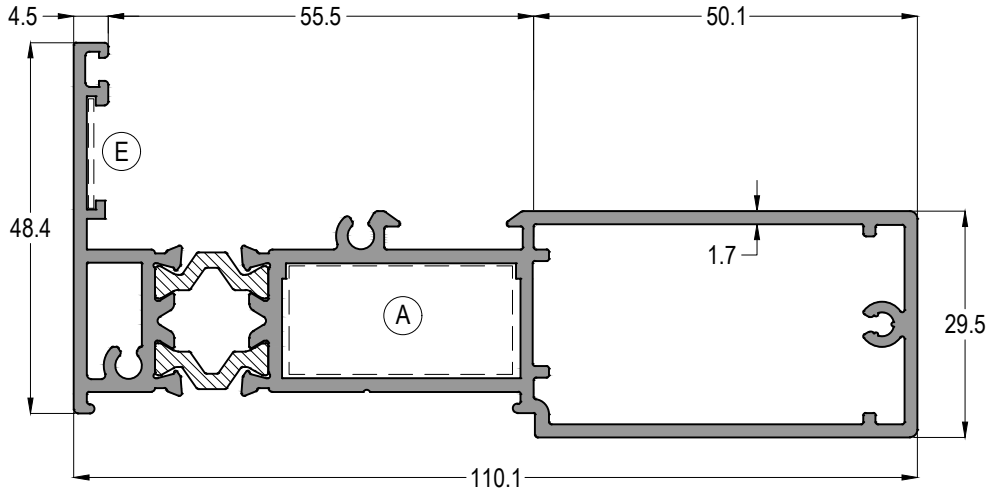

LS60 112		Jx cm ⁴	Jy cm ⁴
		19,15	5,20
 ASI-KT 1429	 ASI-SB 19.1	AĞIRLIK / Weight	
		1,244 kg/mt	



LS60 113		Jx cm ⁴	Jy cm ⁴
		99,15	9,16
 ASI-KT 1429	 ASI-SB 19.1	AĞIRLIK / Weight	
		1,933 kg/mt	



LS60

YALITIMLI KALDIR-SÜR SİSTEM
THERMAL LIFT&SLIDE SYSTEM

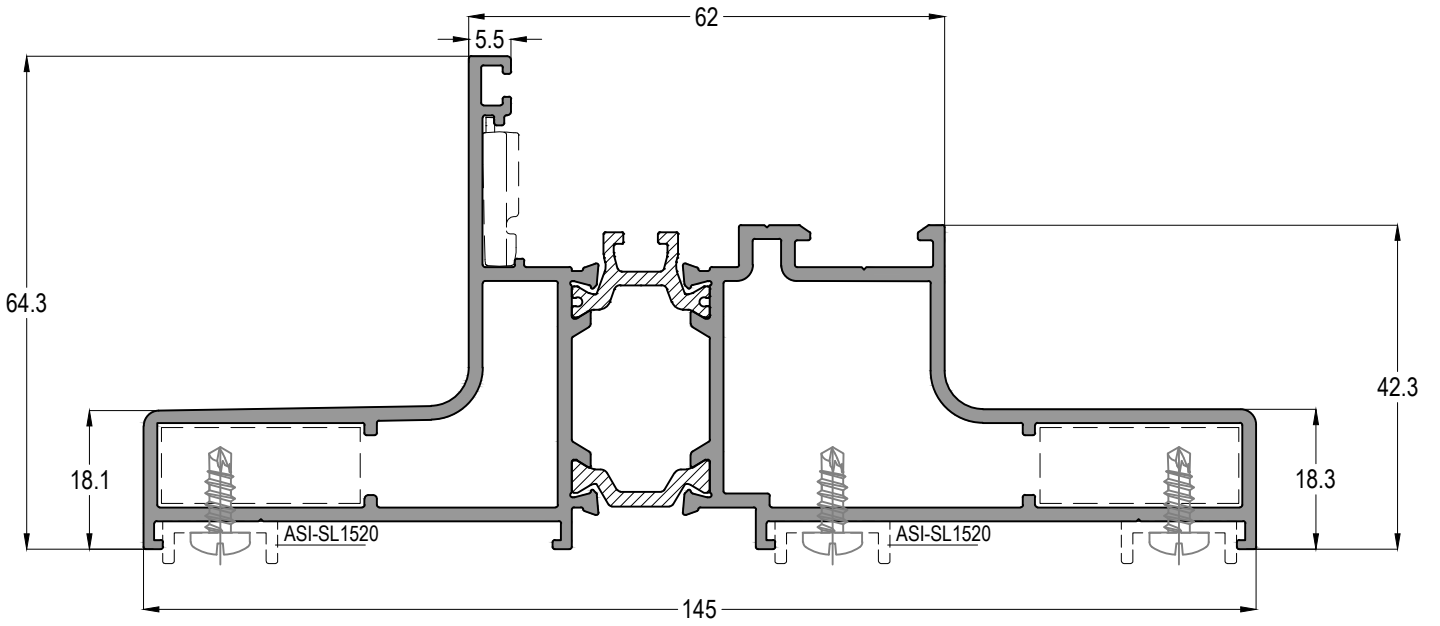
ASISTAL



LS60 62

 ASI-KT 1126 ~ ASI-PB 1126	 ASI-FUJI 2000	AĞIRLIK / Weight 2,418 kg/mt
---	--	---------------------------------

LS60

YALITIMLI KALDIR-SÜR SİSTEM
THERMAL LIFT&SLIDE SYSTEM

ASISTAL

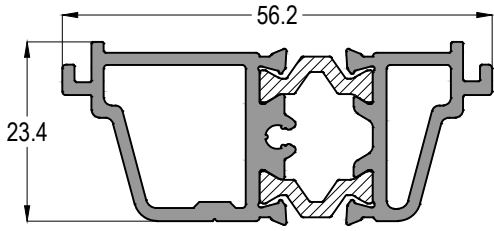

LS60 41



MO60-12

AĞIRLIK / Weight

0,987 kg/mt

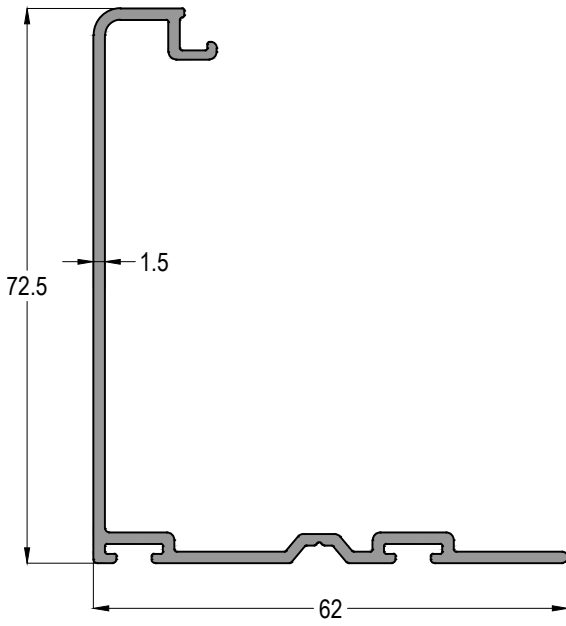

LS60 42

AĞIRLIK / Weight

0,670 kg/mt

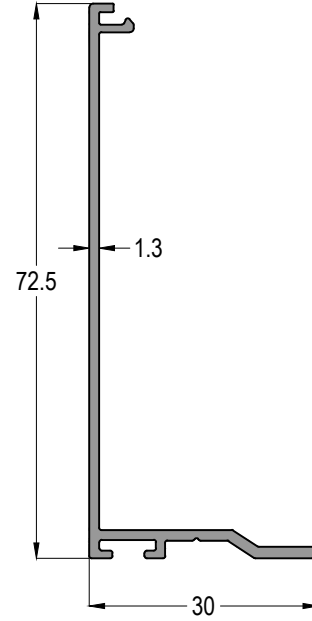

LS60 45

AĞIRLIK / Weight

0,404 kg/mt

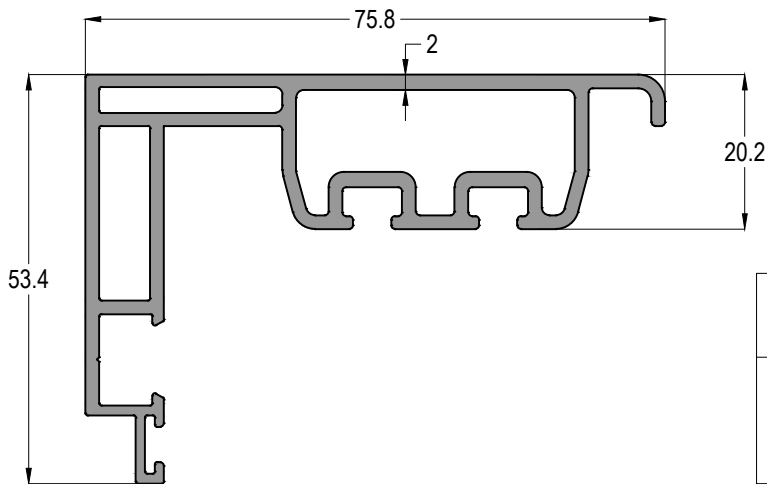

LS60 43

AĞIRLIK / Weight

1,434 g/mt

LS60

YALITIMLI KALDIR-SÜR SİSTEM
THERMAL LIFT&SLIDE SYSTEM

ASISTAL

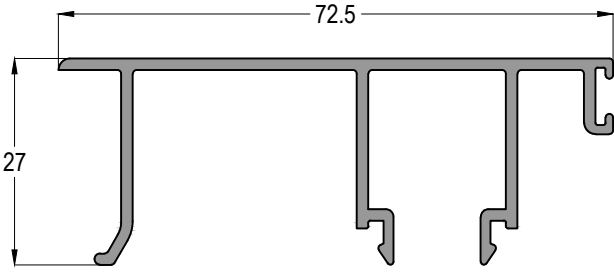

LS60 31

AĞIRLIK / Weight

0,686 kg/mt

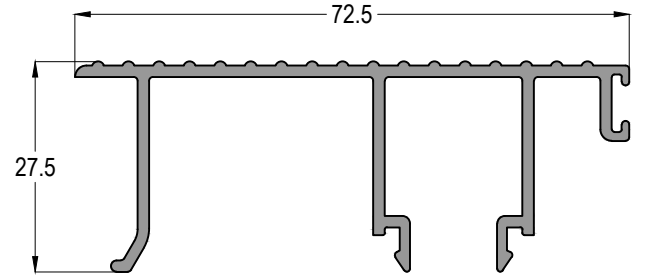

LS60 32

AĞIRLIK / Weight

0,710 kg/mt

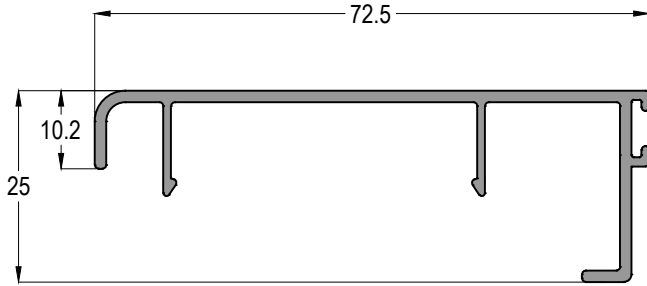

LS60 33

AĞIRLIK / Weight

0,523 kg/mt

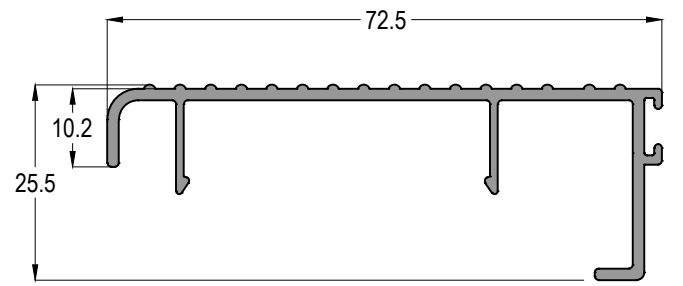

LS60 34

AĞIRLIK / Weight

0,545 kg/mt

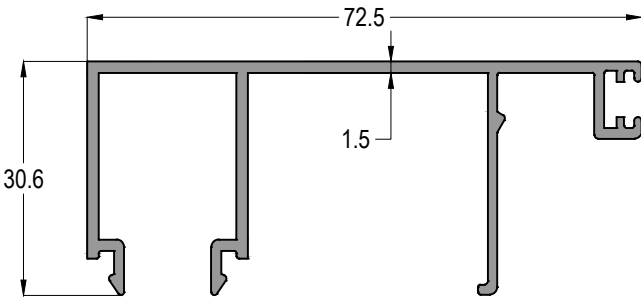

LS60 40

AĞIRLIK / Weight

0,724 kg/mt

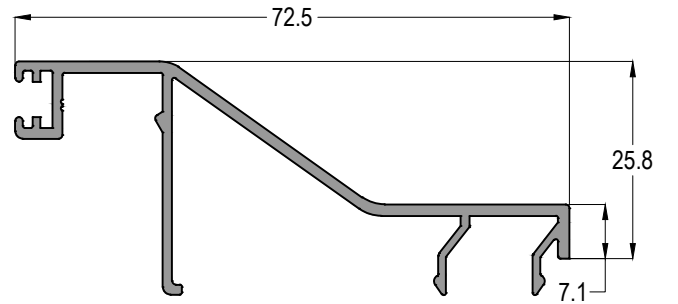

LS60 46

AĞIRLIK / Weight

0,561 kg/mt

LS60

YALITIMLI KALDIR-SÜR SİSTEM
THERMAL LIFT&SLIDE SYSTEM

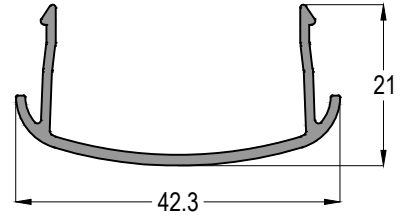
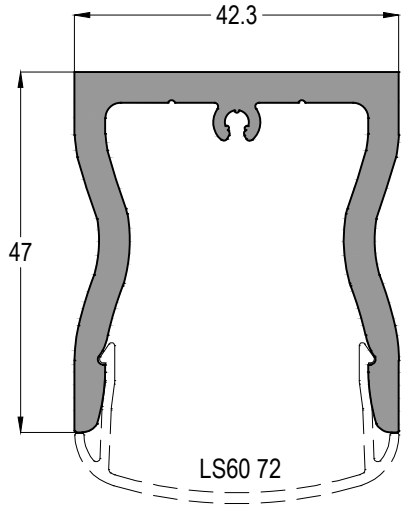

LS60 72

LS60 72	
	AĞIRLIK / Weight
	0,296 kg/mt

LS60 71

 MO60-19	AĞIRLIK / Weight
	1,430 kg/mt

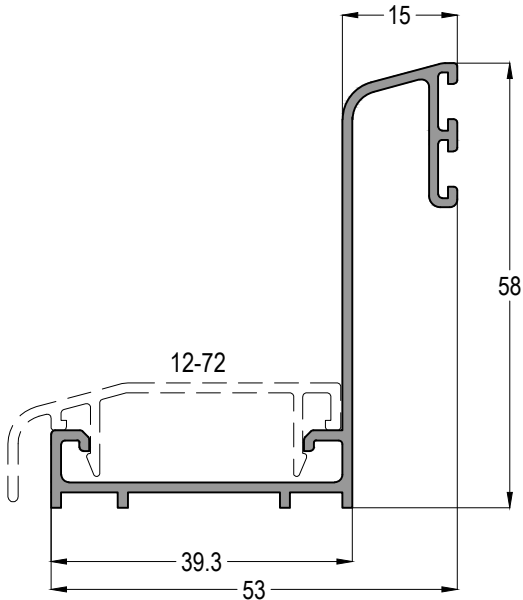

12-71

12-71	
	AĞIRLIK / Weight
	0,545 kg/mt

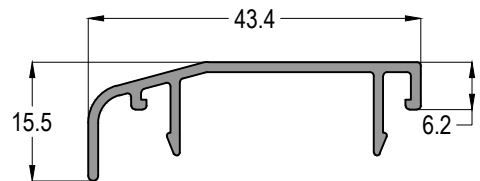

12-72

12-72	
	AĞIRLIK / Weight
	0,286 kg/mt



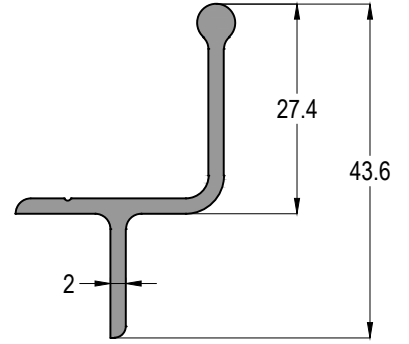
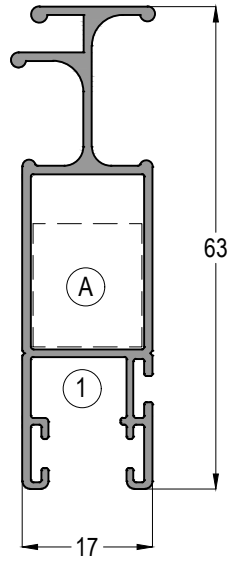
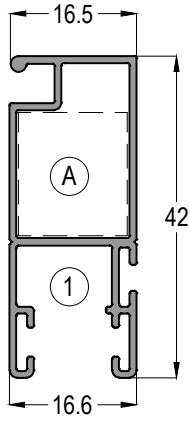

LS60

YALITIMLI KALDIR-SÜR SİSTEM
THERMAL LIFT&SLIDE SYSTEM





ASISTAL



15-304216-09

		AĞIRLIK / Weight
		0,352 kg/mt
ASI-BZ 5007	ASI-BZ 5060	

15-306317-11



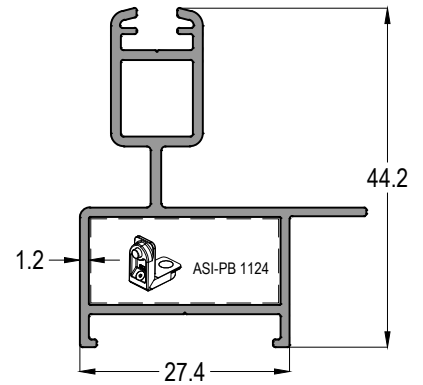
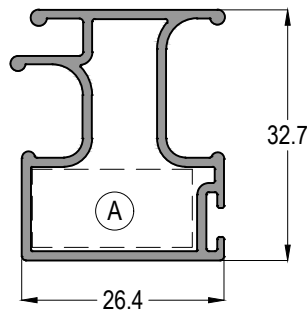
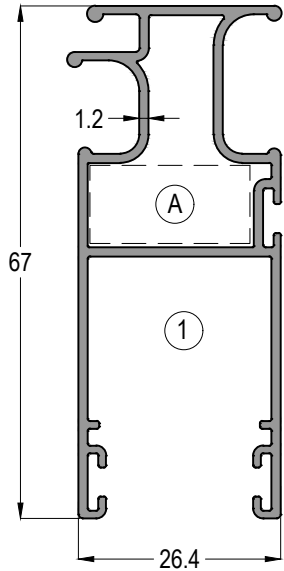

		AĞIRLIK / Weight
		0,561 kg/mt
ASI-BZ 5007	ASI-BZ 5060	

LS60 61





0,391 kg/mt



13-09986

		AĞIRLIK / Weight
		0,741 kg/mt
ASI-PB 1119	ASI-SR 02R	

SL34T-52

		AĞIRLIK / Weight
		0,469 kg/mt
ASI-PB 1119	FLY-KP01	

1042

0,553 kg/mt

LS60

YALITIMLI KALDIR-SÜR SİSTEM
THERMAL LIFT&SLIDE SYSTEM

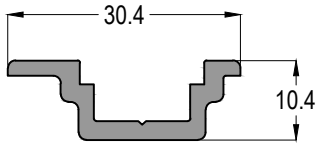

LS60 44
0,285 kg/mt

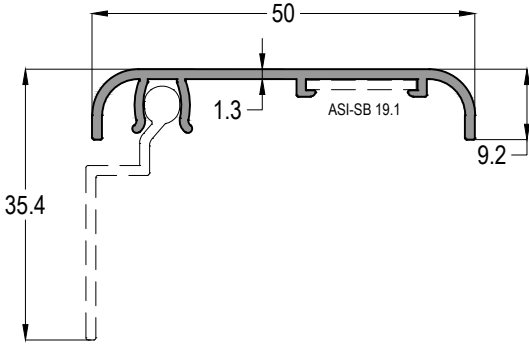

12-52
0,279 kg/mt

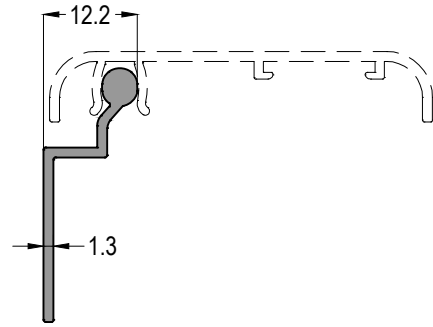

12-53
0,176 kg/mt

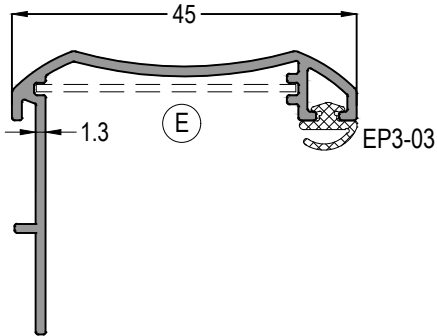

E	12-57
	0,358 kg/mt
ASI-SB 34	

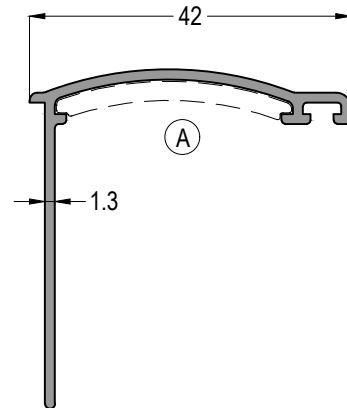

A	12-54
	0,326 kg/mt
EM 12-54	

LS60

YALITIMLI KALDIR-SÜR SİSTEM
THERMAL LIFT&SLIDE SYSTEM

ASISTAL

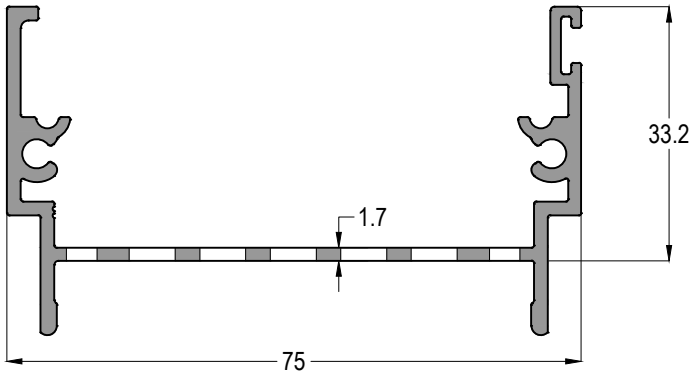
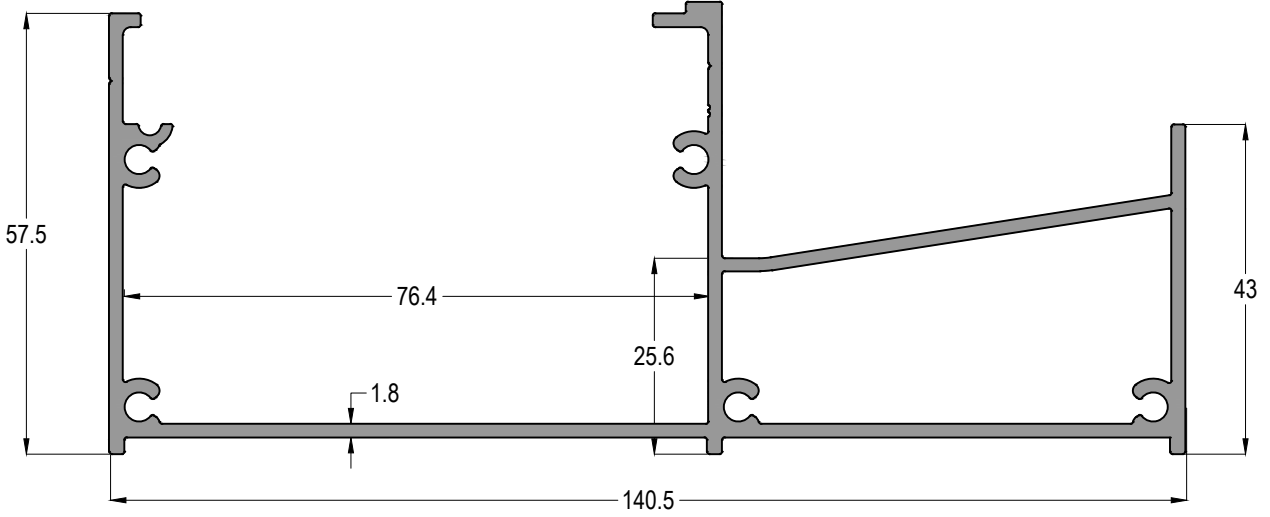

DR-001



AĞIRLIK / Weight

1,998 kg/mt

DR-002

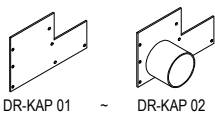

AĞIRLIK / Weight

0,918 kg/mt

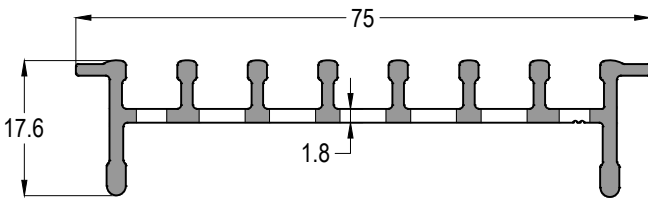

DR-003

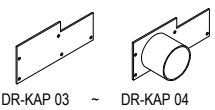

AĞIRLIK / Weight

0,724 kg/mt

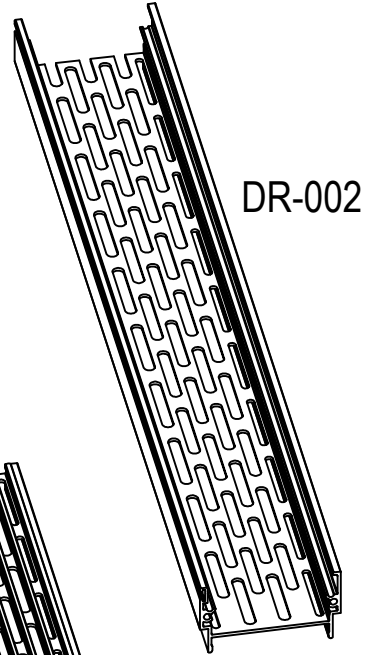

MEKANİK İŞLEMLE DELME YAPILMIŞTIR
DRILLING WAS DONE BY MECHANICAL PROCESS

DR-003

DR-005

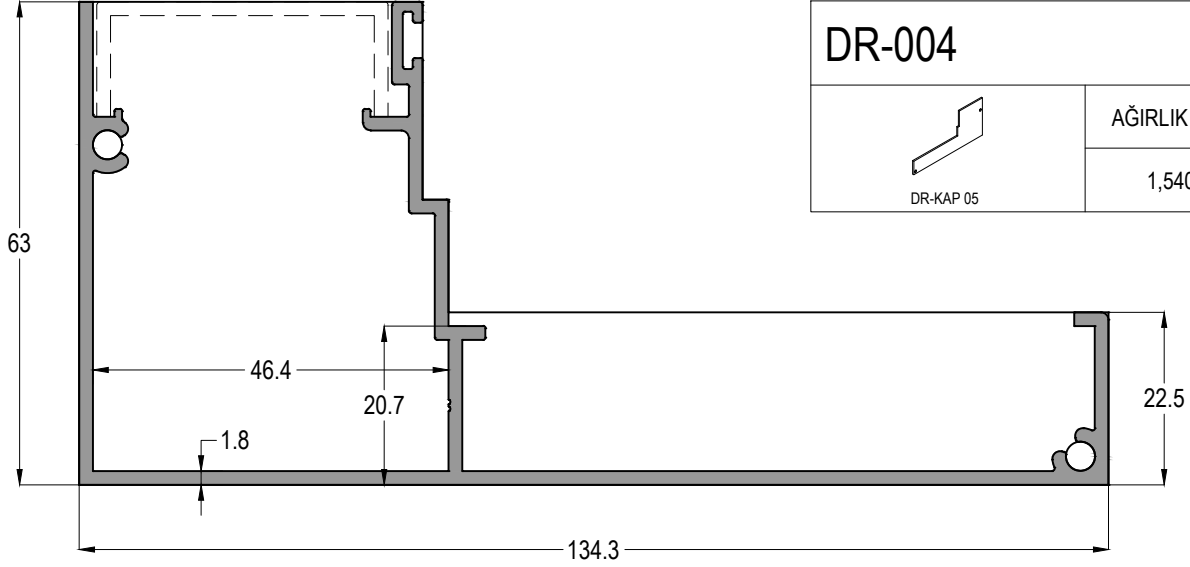

SADECE PRES RENK KULLANILACAKTIR
ONLY PRESS COLOR WILL BE USED

DR-004



DR-KAP 05

AĞIRLIK / Weight

1,540 kg/mt

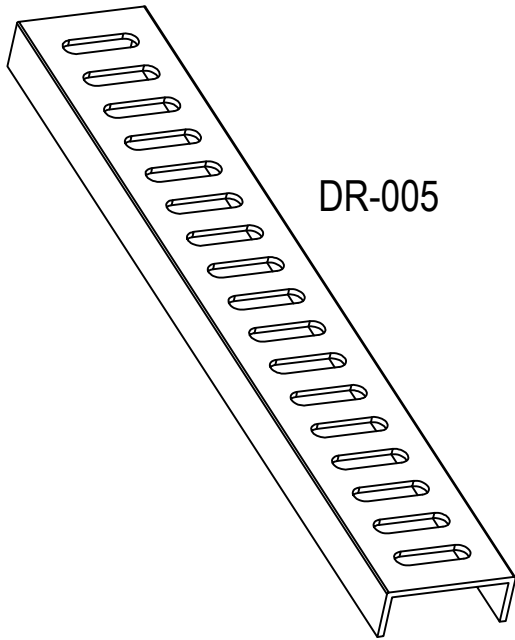

DR-005

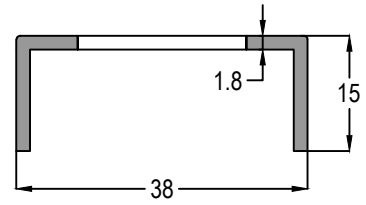

DR-005



DR-KAP 05

AĞIRLIK / Weight

0,308 kg/mt

MEKANİK İŞLEMLE DELME YAPILMIŞTIR
DRILLING WAS DONE BY MECHANICAL PROCESS

SADECE NAT. ELOKSAL KULLANIMI ÖNERİLİR
ONLY NATURAL ANODIZING IS RECOMMENDED

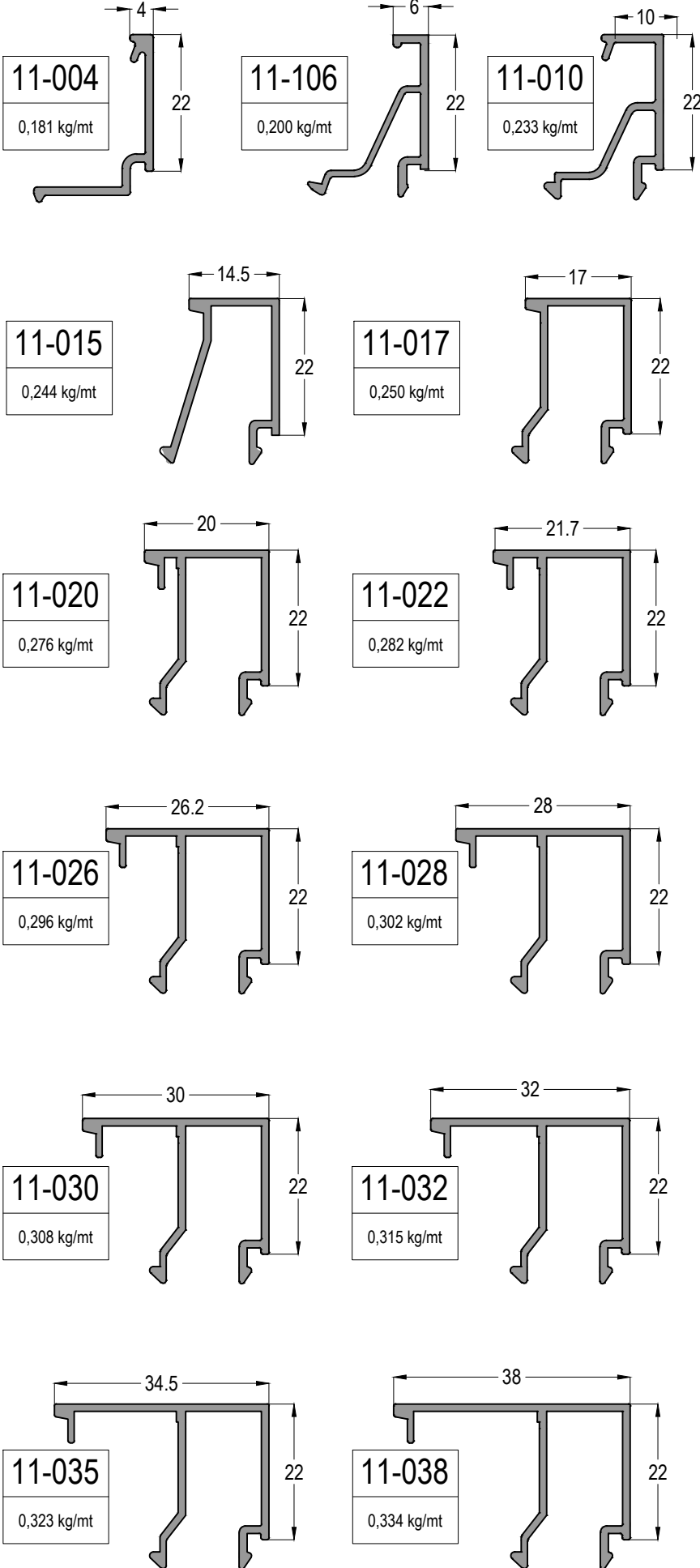

CAM KALINLIĞINA GÖRE CAM ÇİTASI SEÇİM TABLOSU
Glazing Bead Selection Table according to the Glass Thickness

CAM KALINLIĞI Glass Thickness (mm)	CAM ÇİTASI Glazing Bead	İÇ CAM FİTİLİ Glass Gasket (IN)	DIŞ CAM FİTİLİ Glass Gasket (OUT)
10	11-038	EP2-02	EP1-01
11	11-038	EP2-01	EP1-01
12	11-035	EP2-03	EP1-01
13	11-035	EP2-02	EP1-01
14	11-035	EP2-01	EP1-01
15	11-032	EP2-03	EP1-01
16	11-032	EP2-02	EP1-01
17	11-032	EP2-01	EP1-01
18	11-030	EP2-02	EP1-01
19	11-030	EP2-01	EP1-01
20	11-028	EP2-02	EP1-01
21	11-028	EP2-01	EP1-01
22	11-026	EP2-02	EP1-01
23	11-026	EP2-01	EP1-01
24	11-022	EP2-03	EP1-01
25	11-022	EP2-02	EP1-01
26	11-022	EP2-01	EP1-01
28	11-020	EP2-02	EP1-01
29	11-020	EP2-01	EP1-01
30	11-017	EP2-03	EP1-01
31	11-017	EP2-02	EP1-01
32	11-017	EP2-01	EP1-01
33	11-015	EP2-02	EP1-01
34	11-015	EP2-01	EP1-01
38	11-010	EP2-02	EP1-01
39	11-010	EP2-01	EP1-01
40	11-106	EP2-03	EP1-01
42	11-106	EP2-02	EP1-01
43	11-106	EP2-01	EP1-01
44	11-004	EP2-02	EP1-01
45	11-004	EP2-02	EP1-01
46	11-004	KC-02	EP1-01

AÇILIM TİPLERİ NORMAL SÜRME - OPENING TYPES NORMAL SLIDING

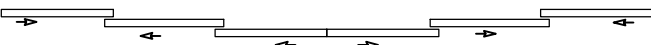
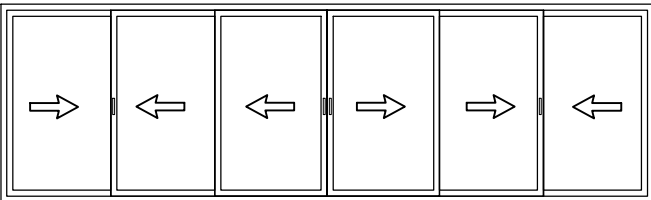
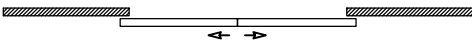
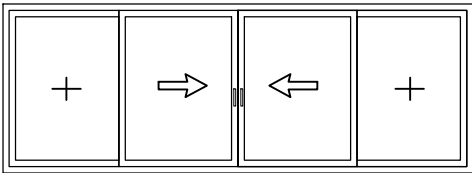
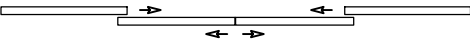
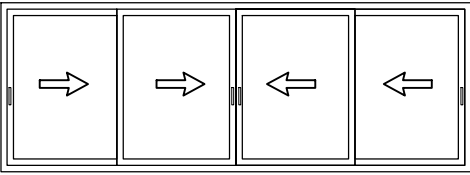
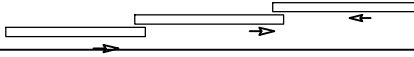
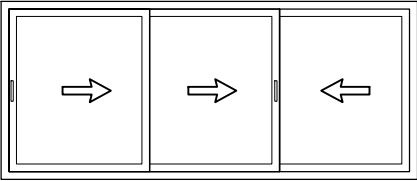
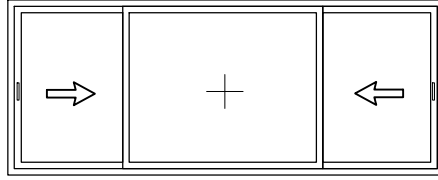
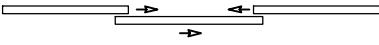
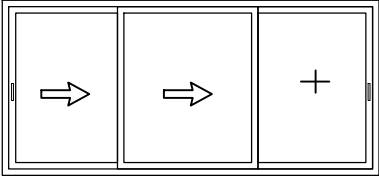
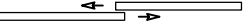
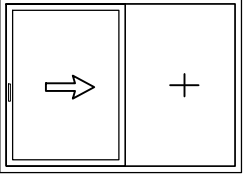
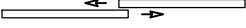
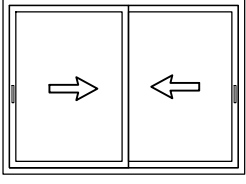

AÇILIM TİPLERİ KALDIR-SÜR SÜRME - OPENING TYPES LIFT & SLIDING

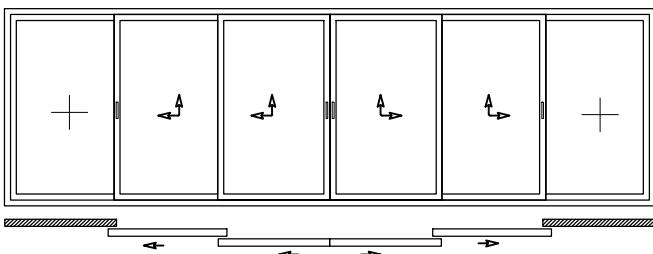
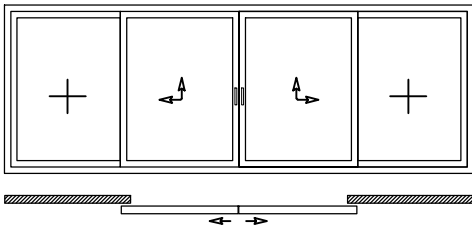
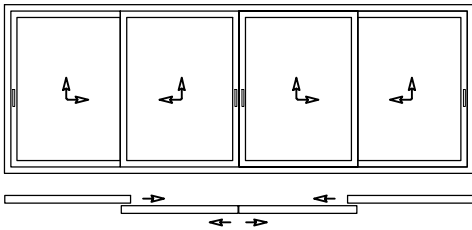
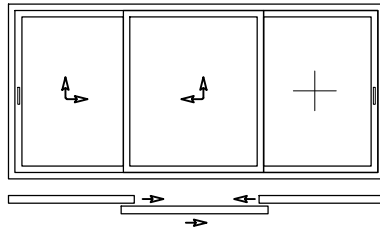
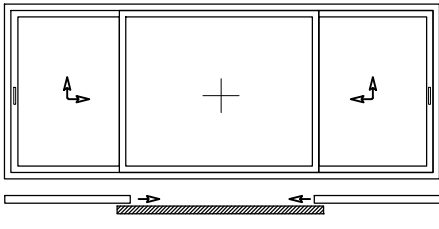
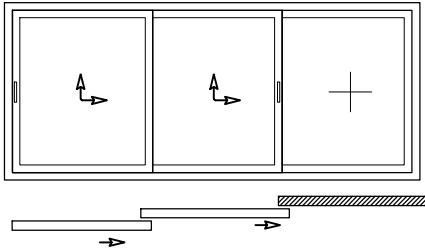
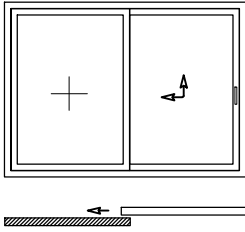
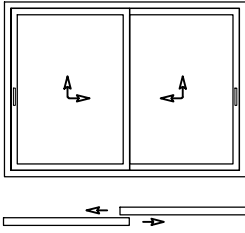

RÜZGAR YÜKÜNE GÖRE MAKSİMUM KANAT EBATLARI

MAXIMUM SASH DIMENSIONS FOR GIVEN WIND PRESSURE

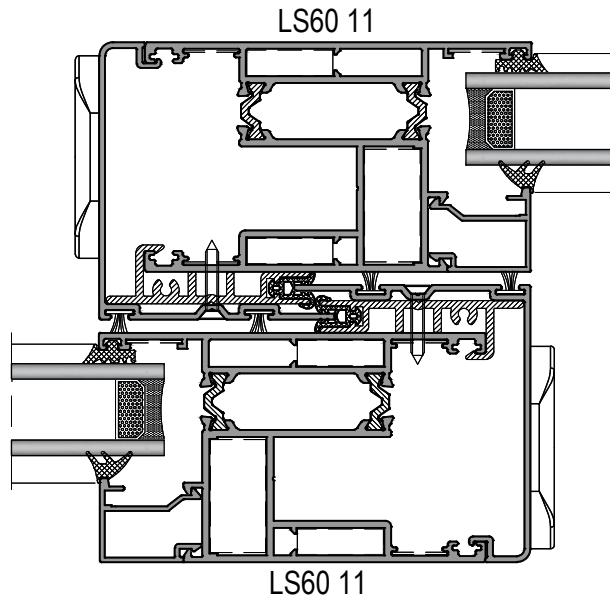
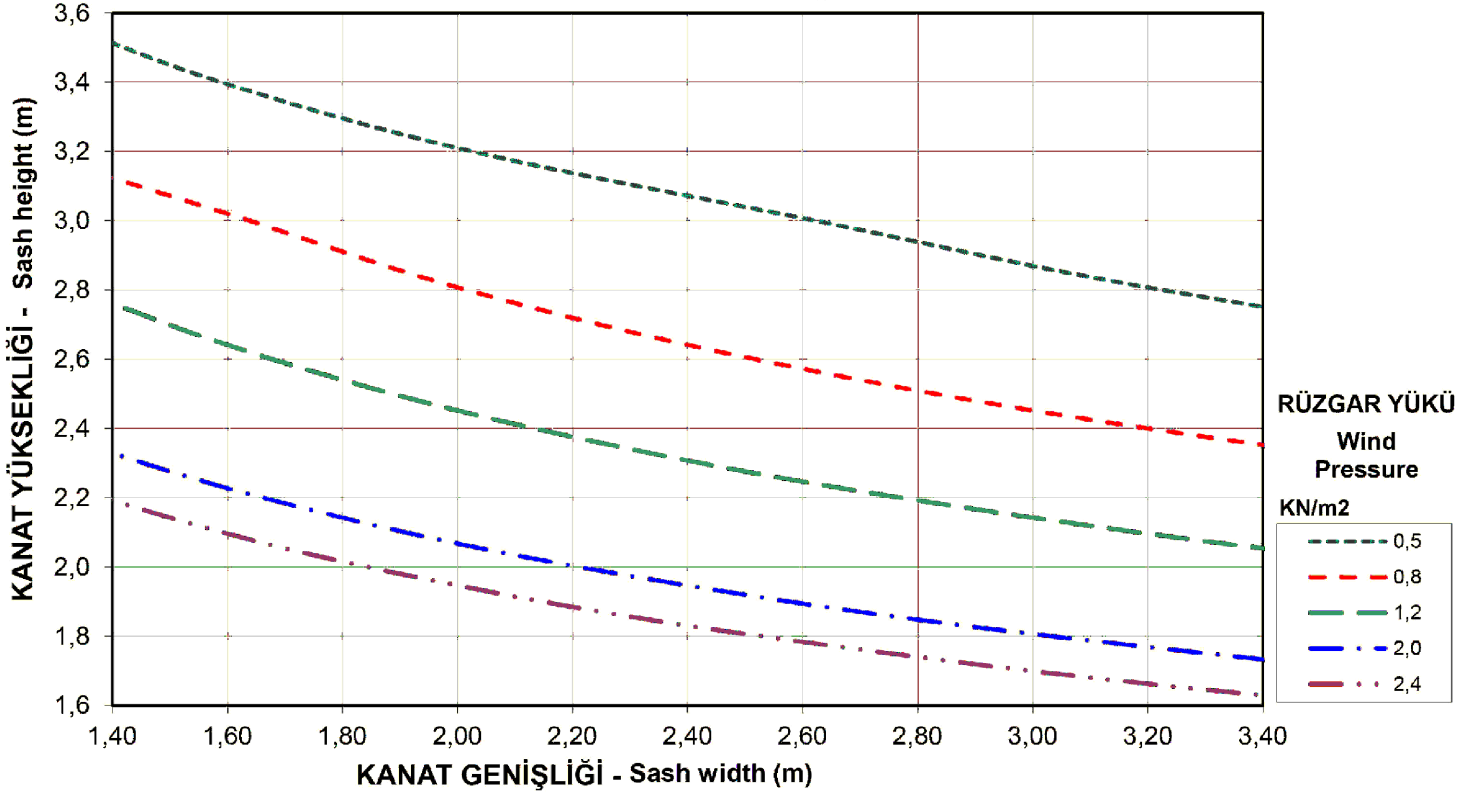

KANAT EBATLARI BELİRLENİRKEN MEKANİZMANIN TAŞIMA KAPASİTESİNİ GEÇMEMESİNE DİKKAT EDİLMELİDİR

WHILE THE SASH DIMENSIONS DETERMINED, SASH WEIGHT MUST BE LESS THAN ROLLER CARY CAPACITY

RÜZGAR YÜKÜNE GÖRE MAKSİMUM KANAT EBATLARI

MAXIMUM SASH DIMENSIONS FOR GIVEN WIND PRESSURE

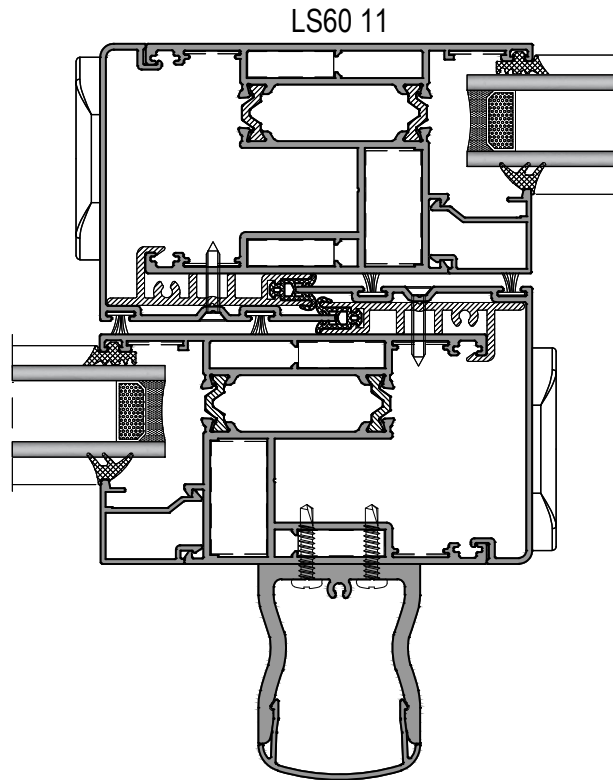
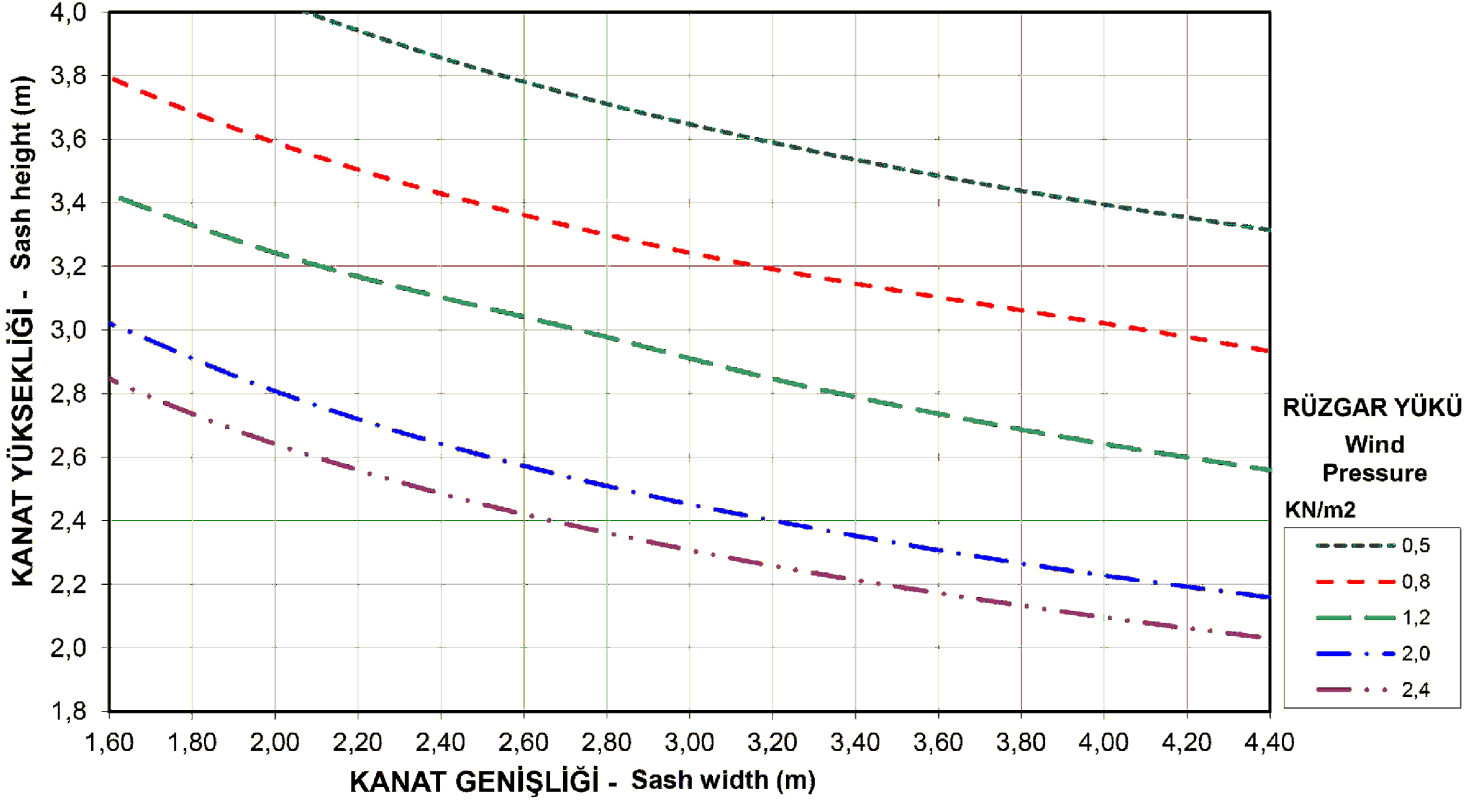

KANAT EBATLARI BELİRLENİRKEN MEKANİZMANIN TAŞIMA KAPASİTESİNİ GEÇMEMESİNE DİKKAT EDİLMELİDİR

WHILE THE SASH DIMENSIONS DETERMINED, SASH WEIGHT MUST BE LESS THAN ROLLER CARY CAPACITY

LS60

YALITIMLI KALDIR-SÜR SİSTEM
THERMAL LIFT&SLIDE SYSTEM

ASISTAL

SİSTEM DETAYLARI
SYSTEM DETAILS

LS60

YALITIMLI KALDIR-SÜR SİSTEMİ
THERMAL LIFT&SLIDE SYSTEM

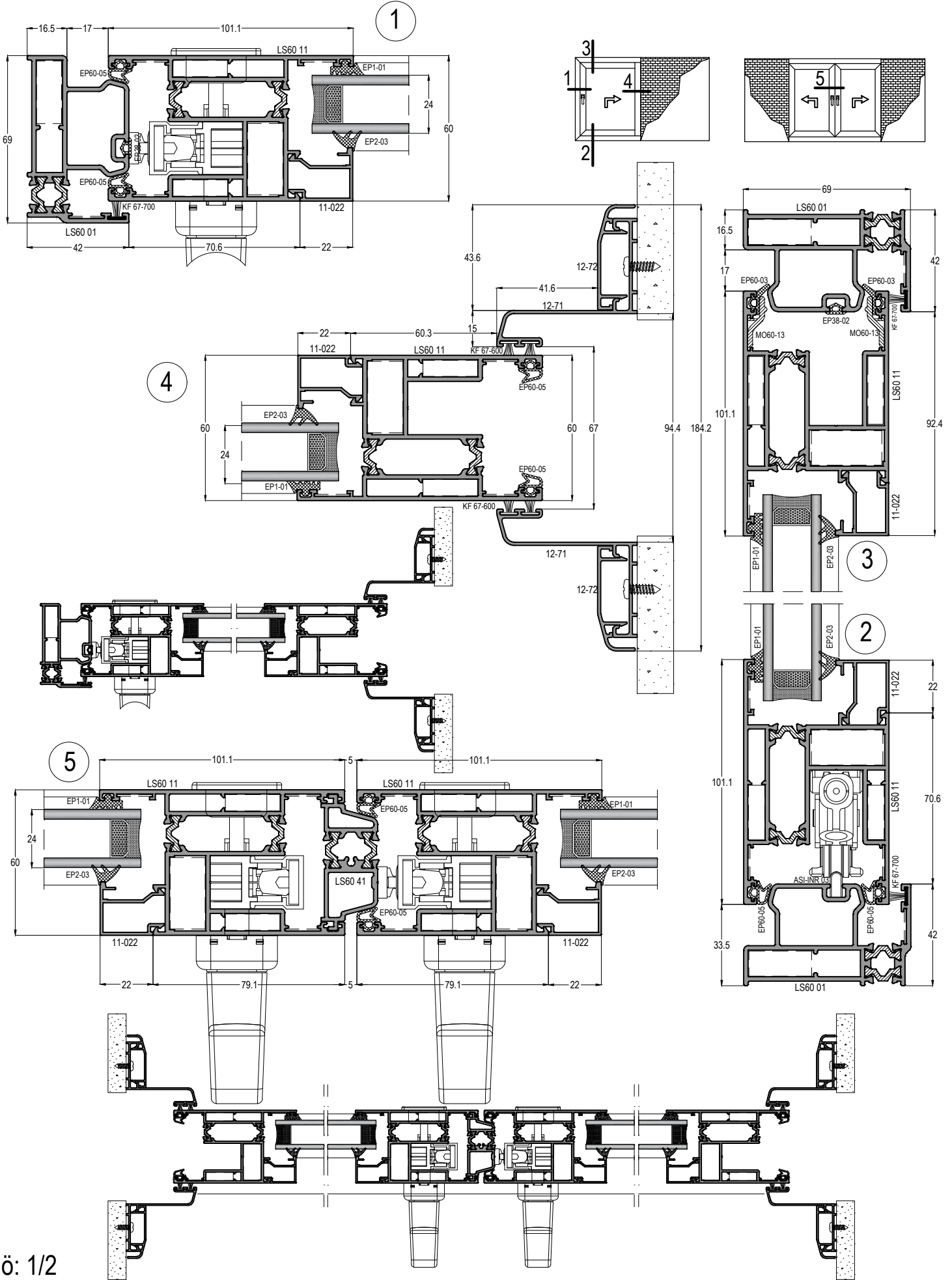

LS60

YALITIMLI KALDIR-SÜR SİSTEM
THERMAL LIFT&SLIDE SYSTEM

ASISTAL

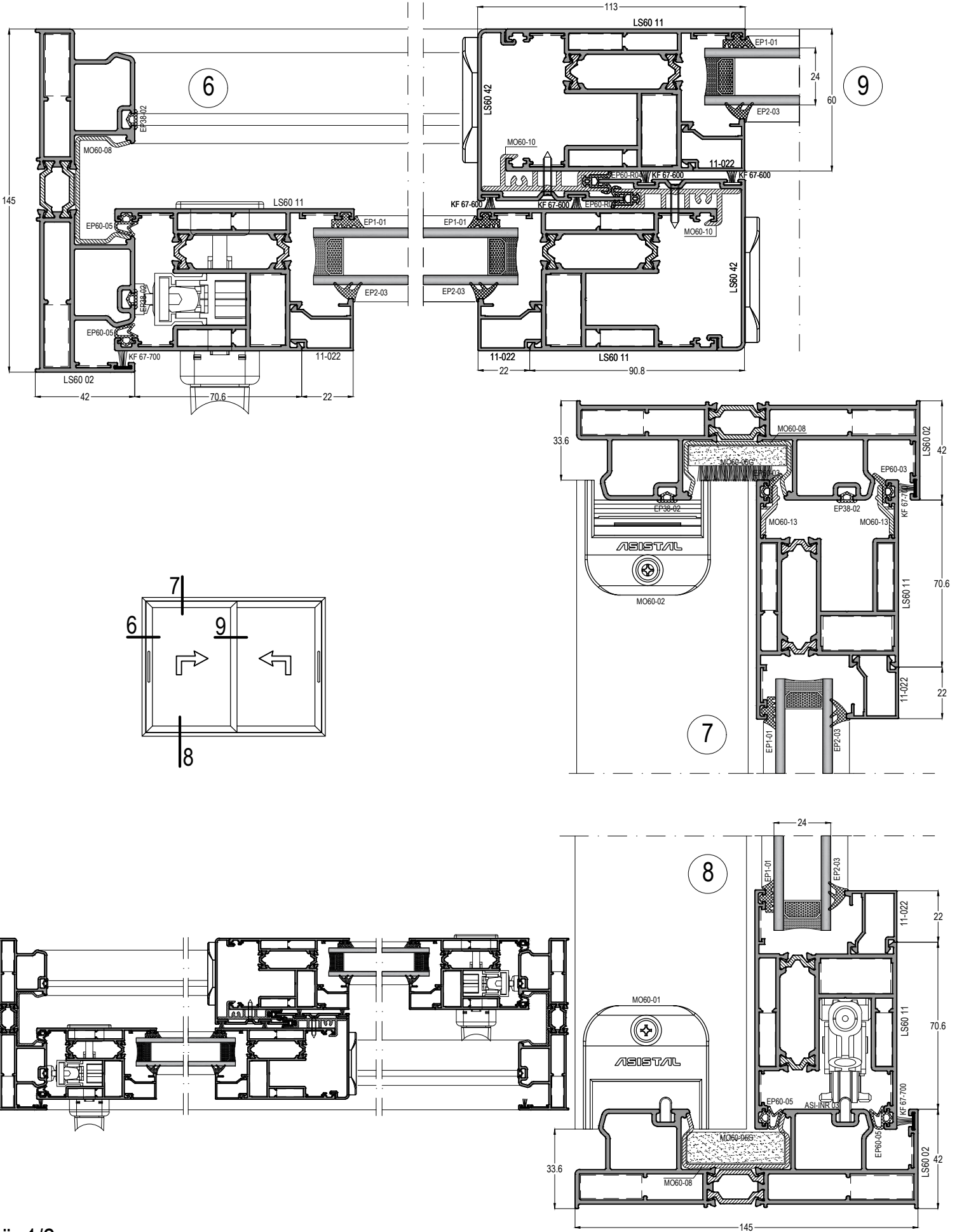



LS60 102 KASA DETAYLARI FRAME DETAILS - LS60 102

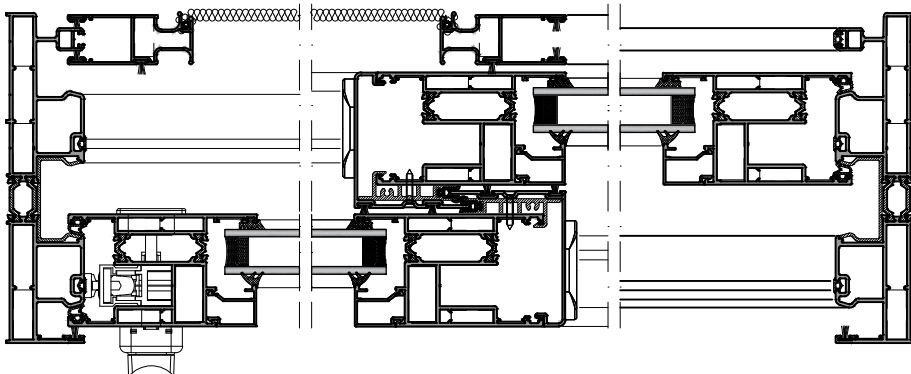
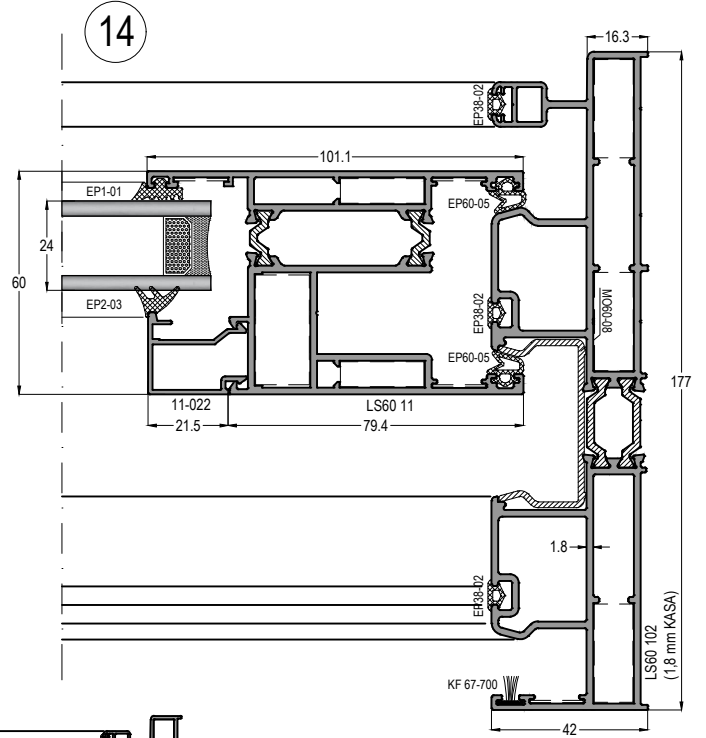
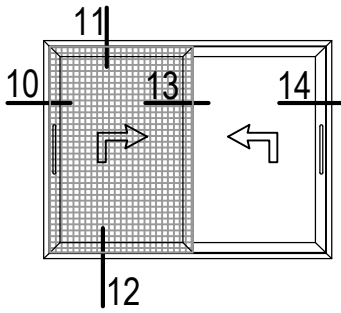
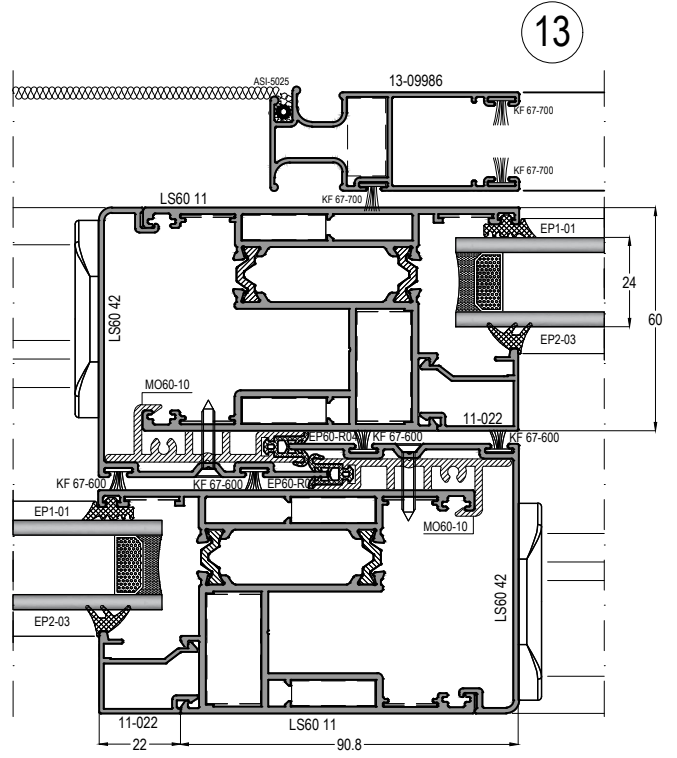
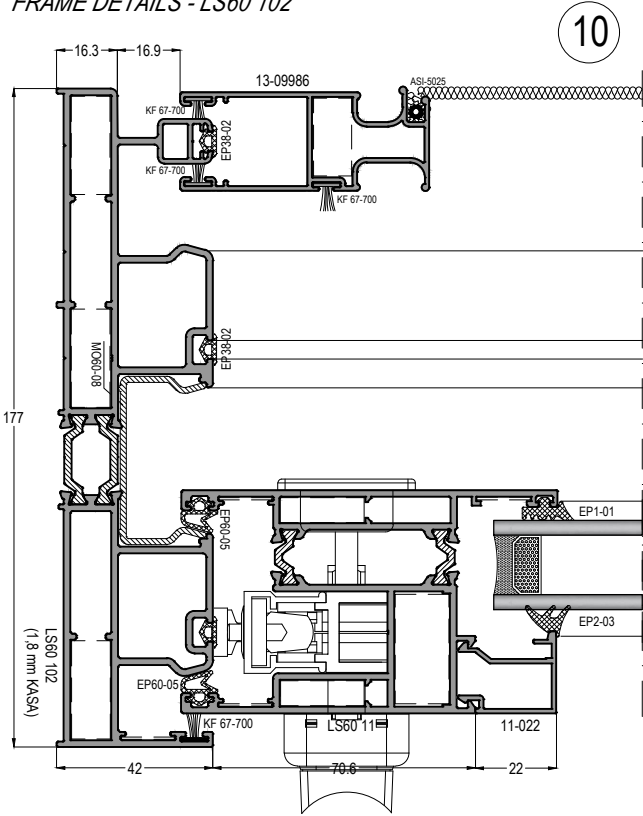

LS60

YALITIMLI KALDIR-SÜR SİSTEM
THERMAL LIFT&SLIDE SYSTEM



LS60 102 KASA DETAYLARI FRAME DETAILS - LS60 102

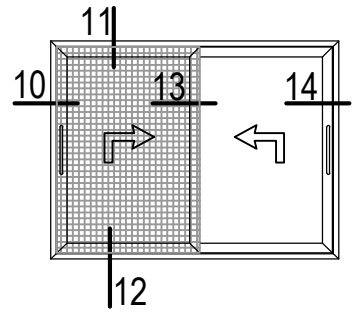

11

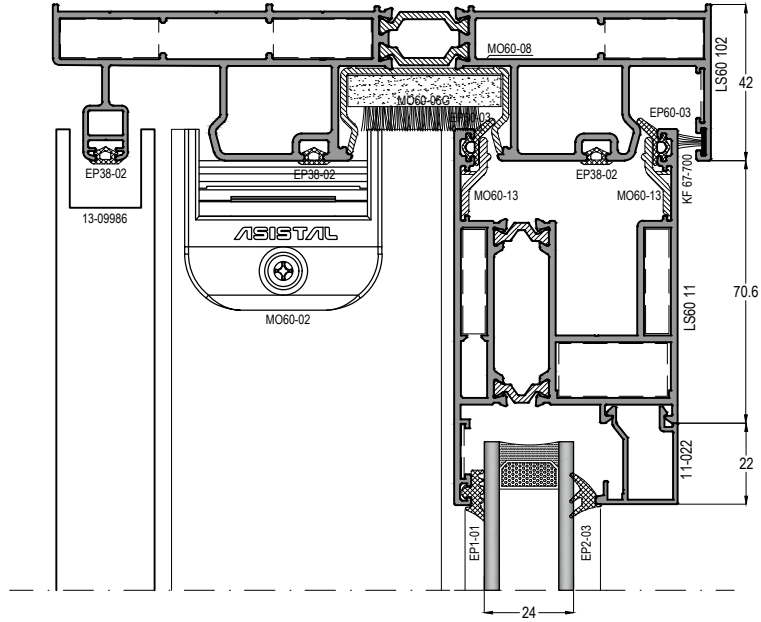

12

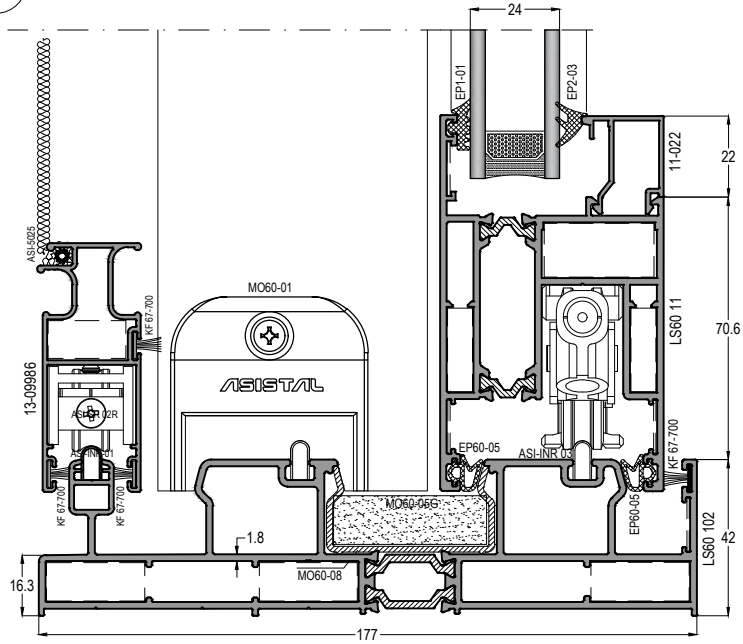

LS60

YALITIMLI KALDIR-SÜR SİSTEMİ
THERMAL LIFT&SLIDE SYSTEM



16

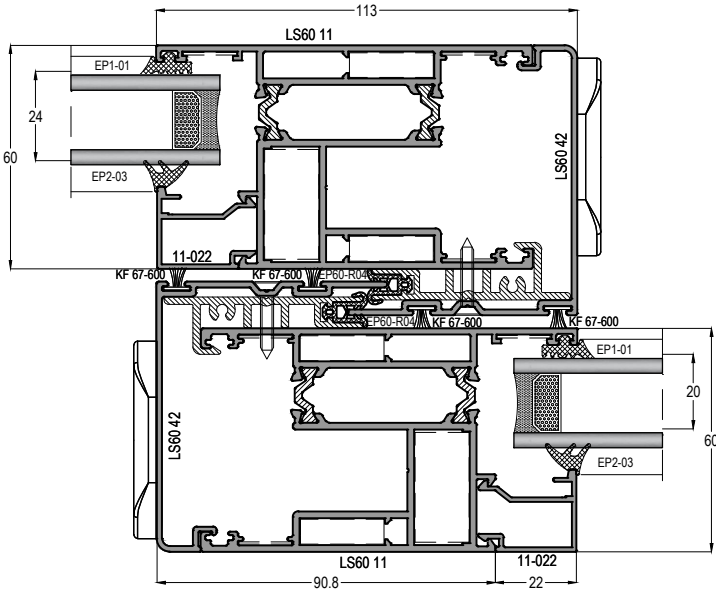

17

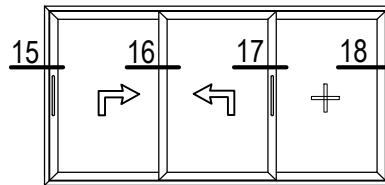
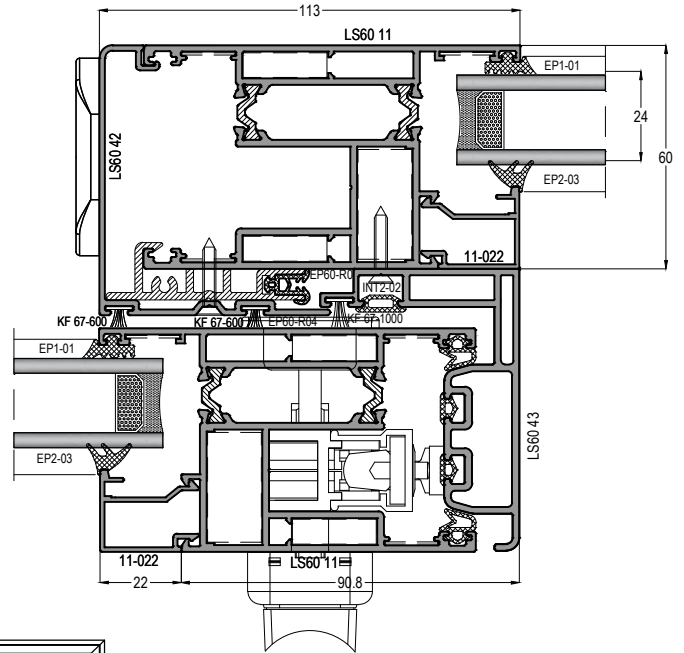

15

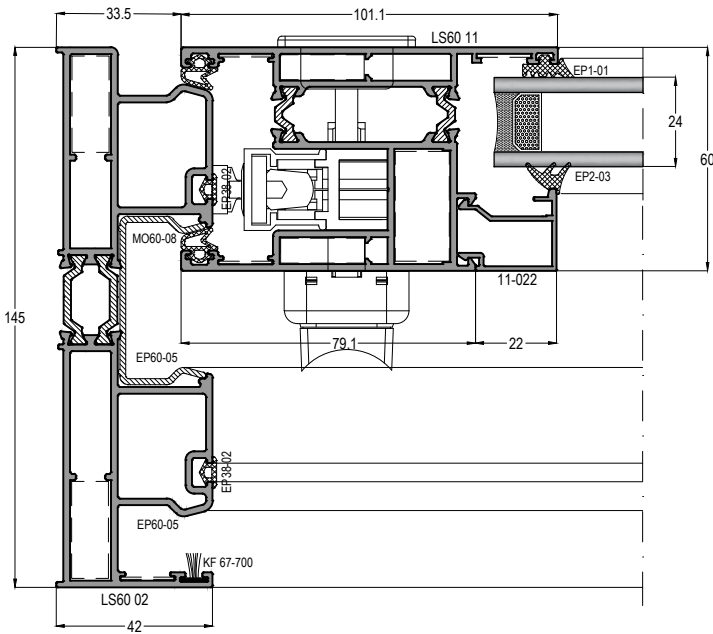

18

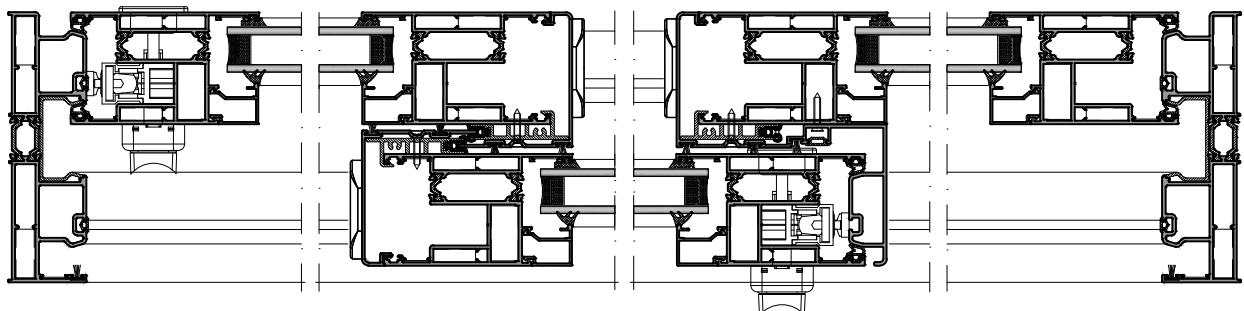
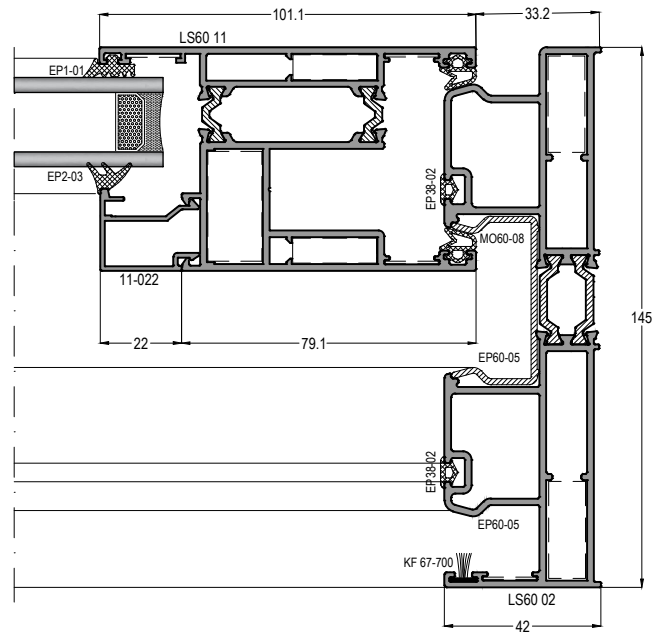

LS60

YALITIMLI KALDIR-SÜR SİSTEMİ
THERMAL LIFT&SLIDE SYSTEM



21

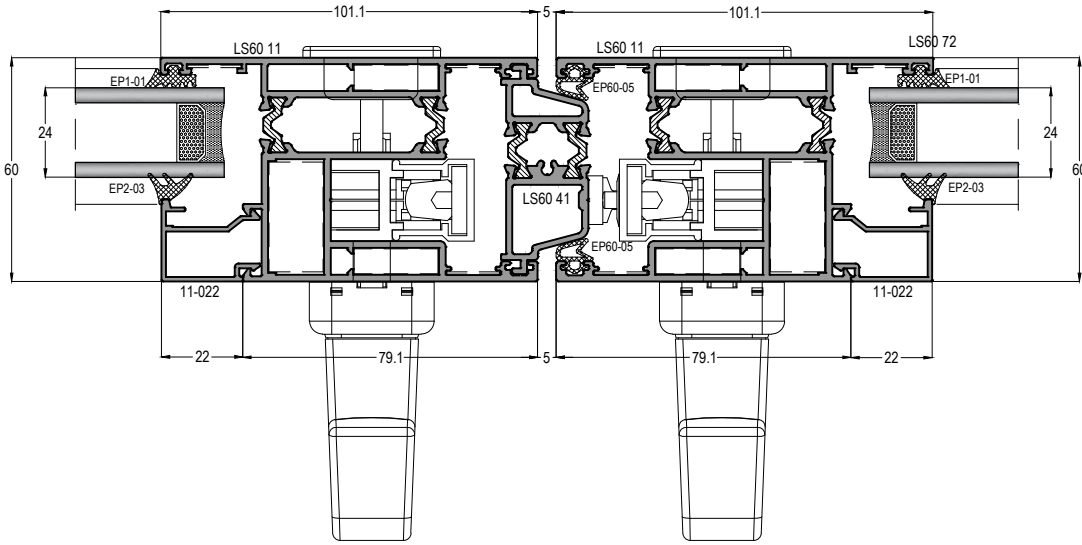

20

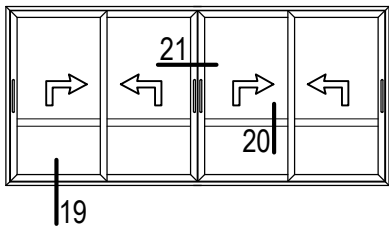
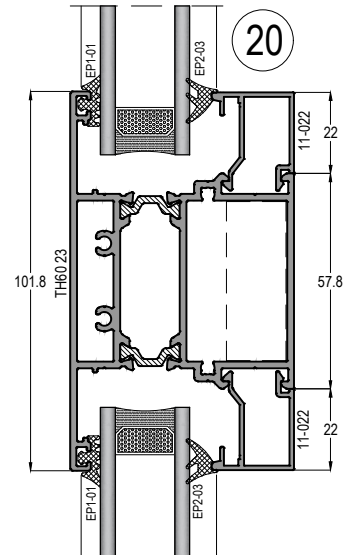

19

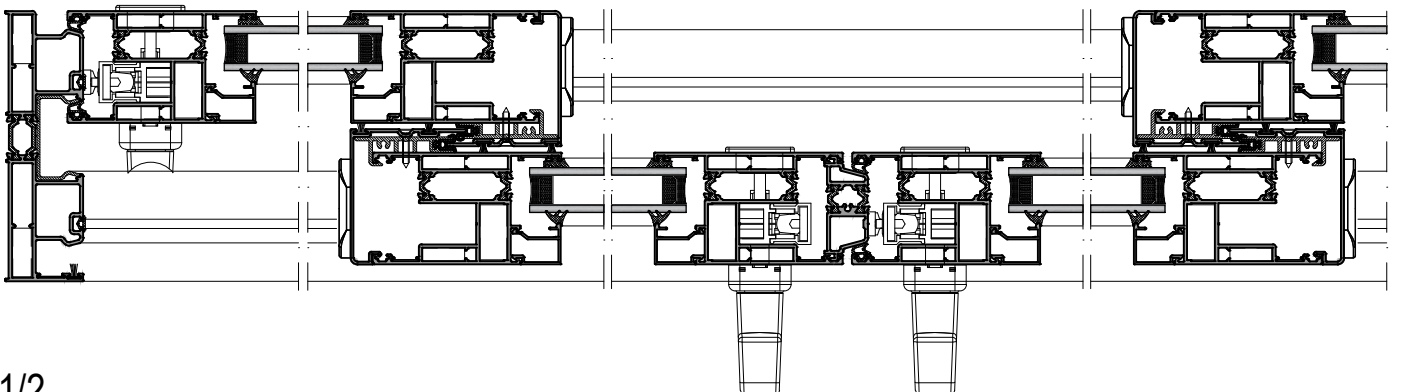
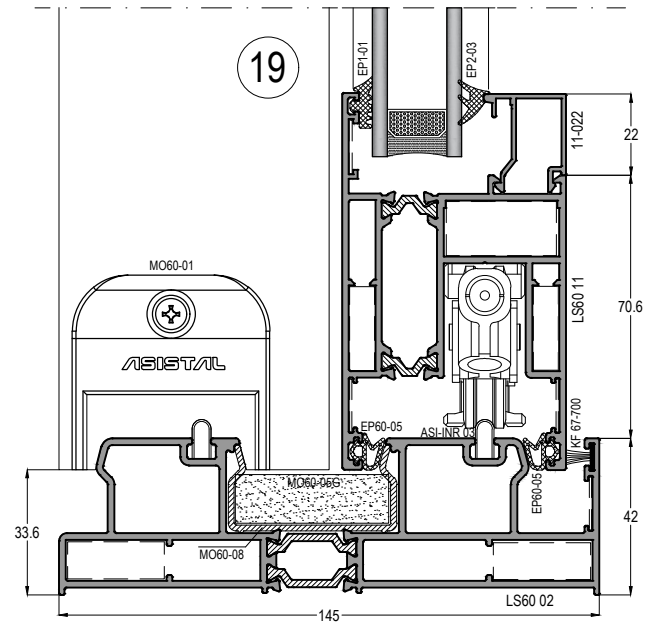

LS60 - 1,4mm

YALITIMLI KALDIR-SÜR SİSTEM
THERMAL LIFT&SLIDE SYSTEM



SİNEKLİK DETAYLARI FLY SCREEN DETAILS

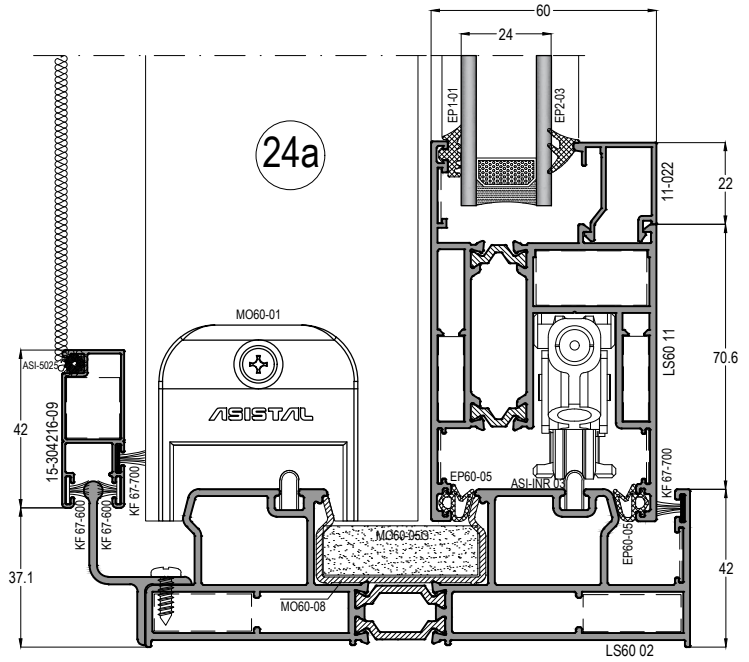
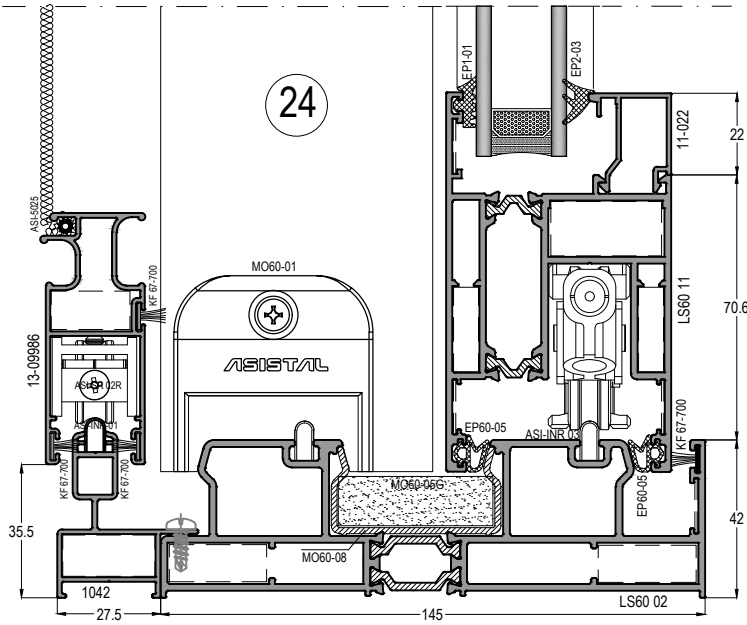

SİNEKLİK DETAYLARI - 1,4 mm FLY SCREEN DETAILS - 1,4 mm

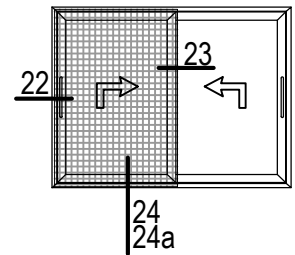
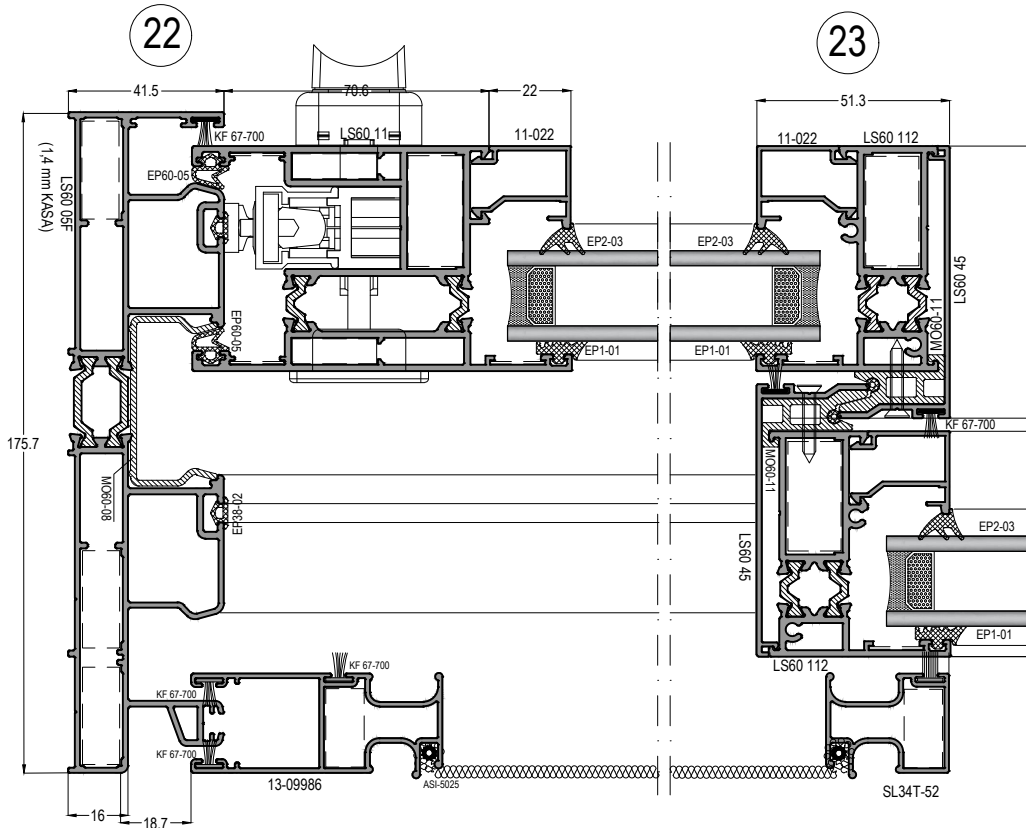

LS60

YALITIMLI KALDIR-SÜR SİSTEM
THERMAL LIFT&SLIDE SYSTEM



ORTA KENET KİLİTLEME DETAYLARI CENTRAL LOCKING DETAILS

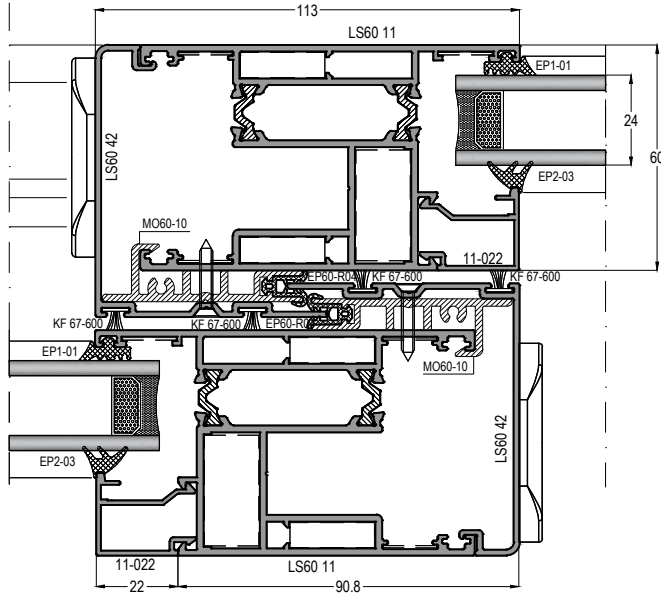

25

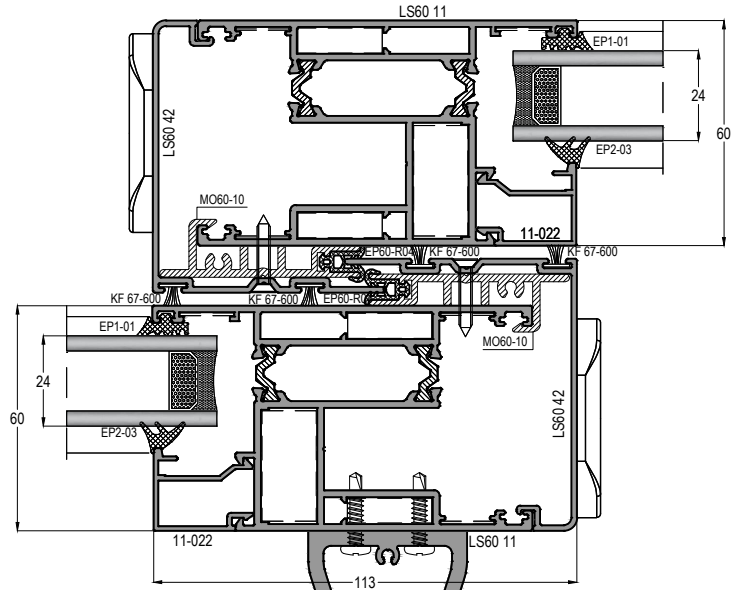

25a

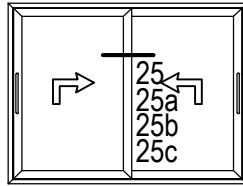

LS60 72

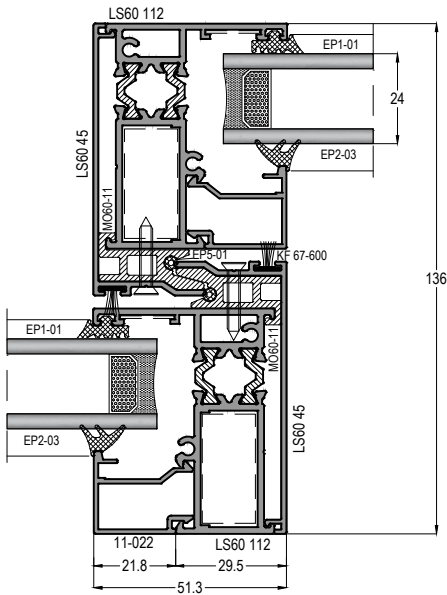

25b

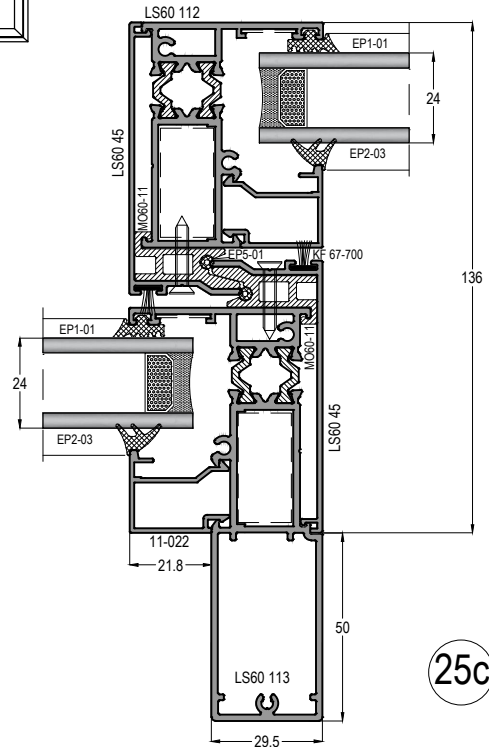

25c

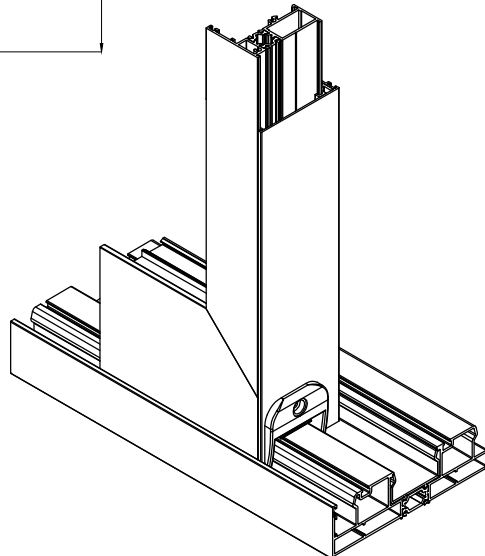

LS60

YALITIMLI KALDIR-SÜR SİSTEM
THERMAL LIFT&SLIDE SYSTEM

ASISTAL

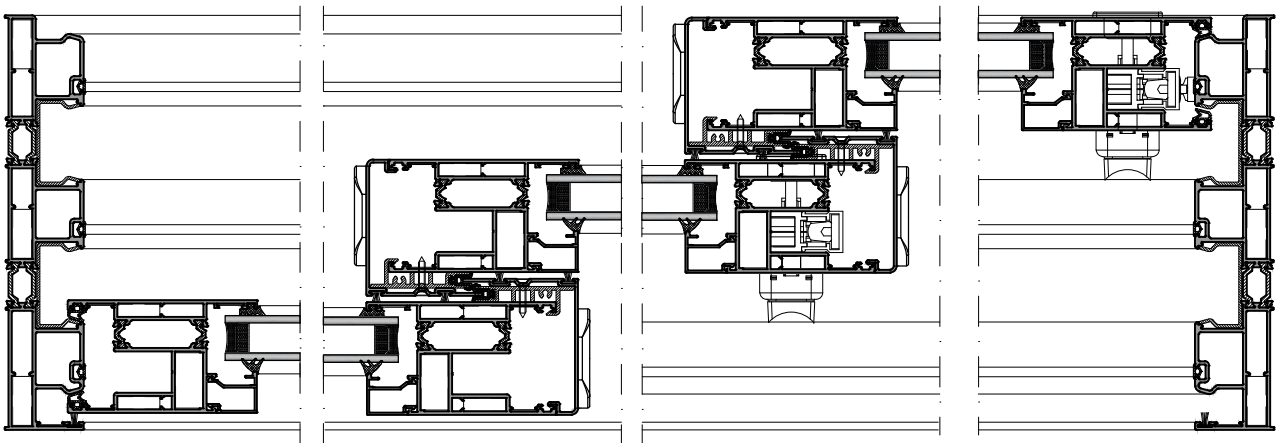
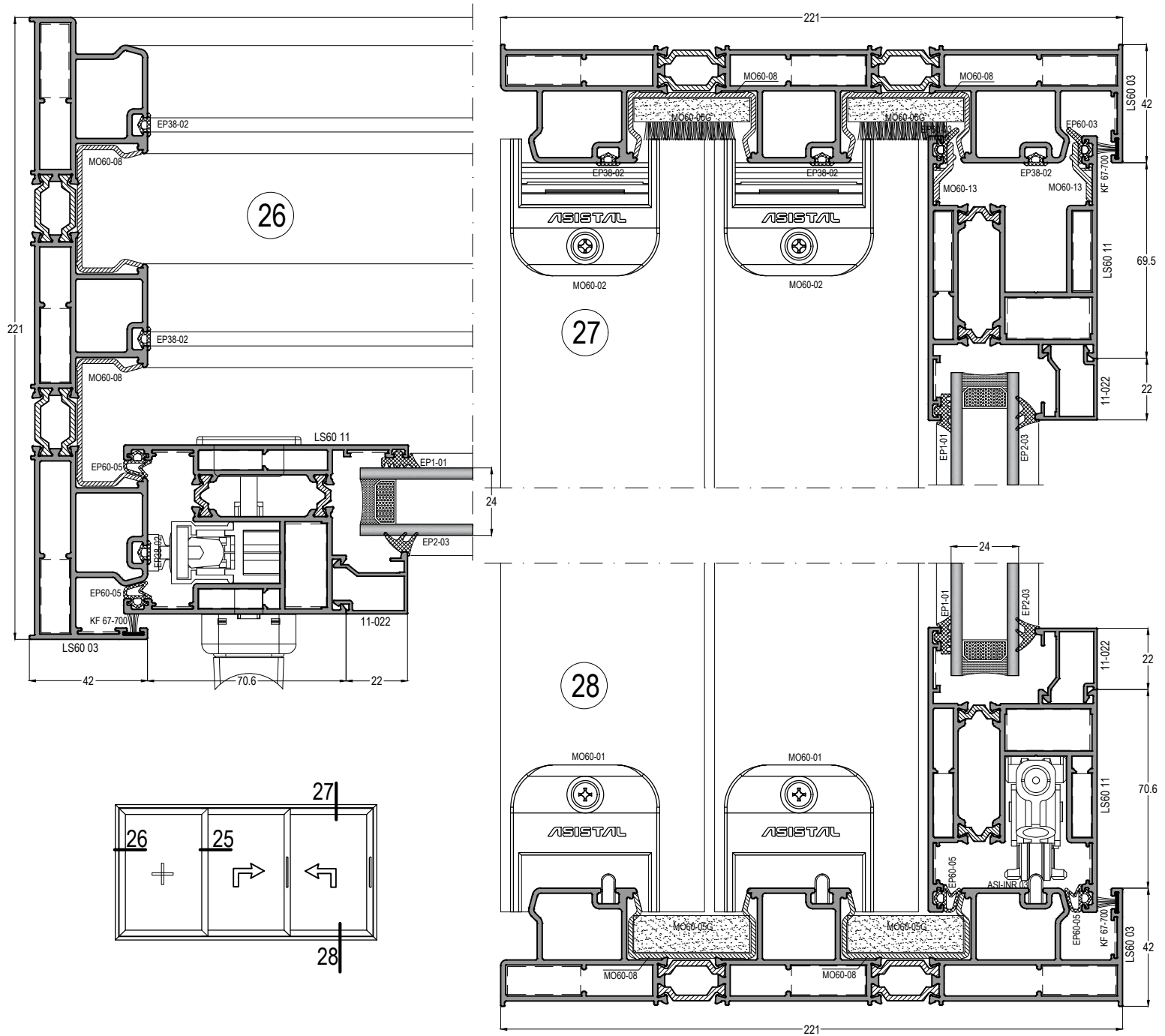



LS60 103 KASA DETAYLARI FRAME DETAILS - LS60 103

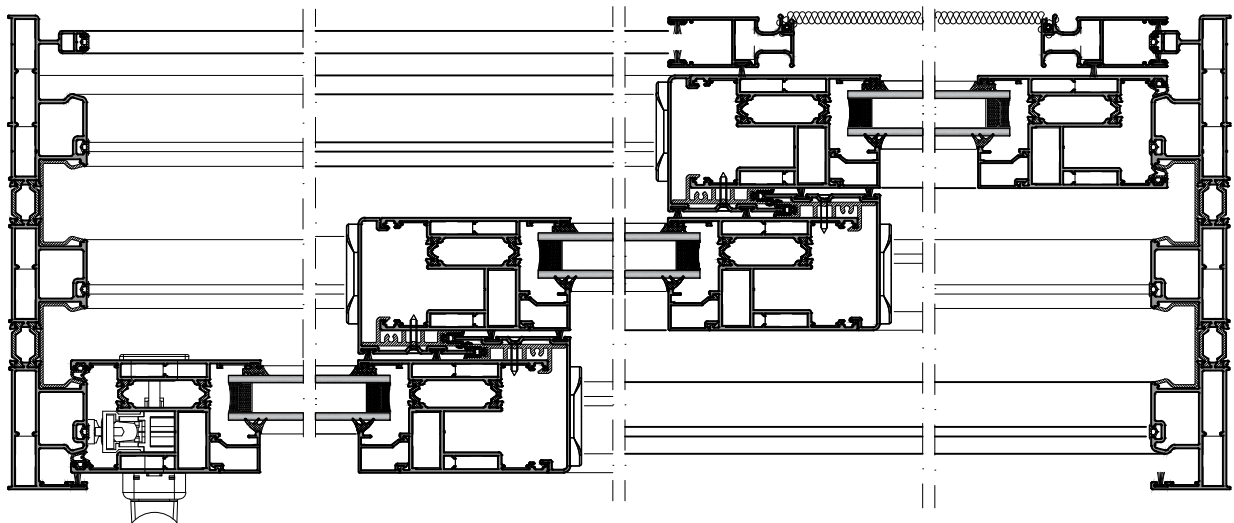
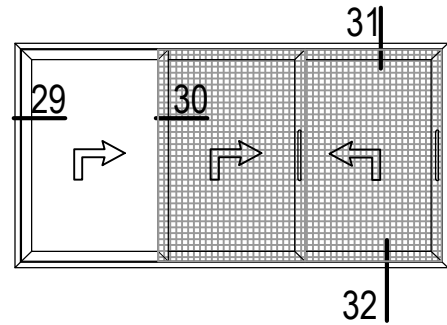
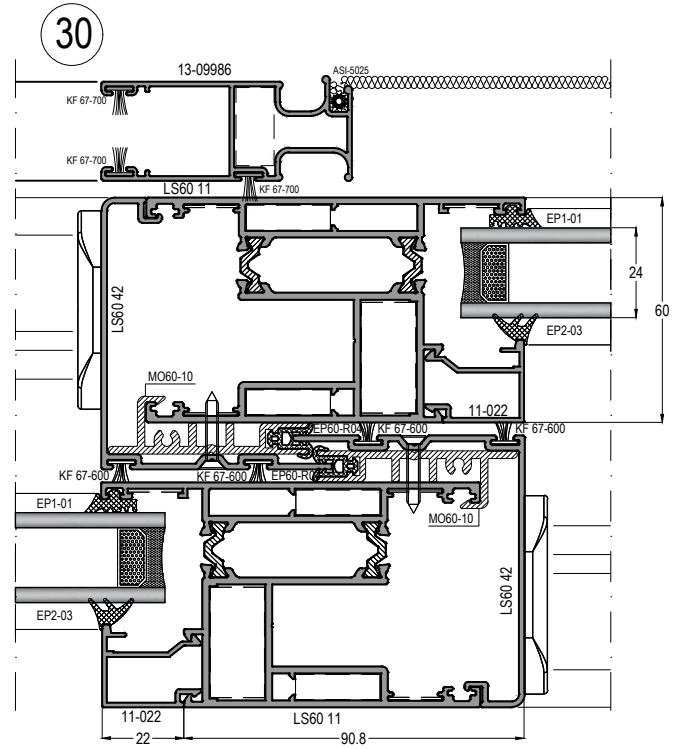
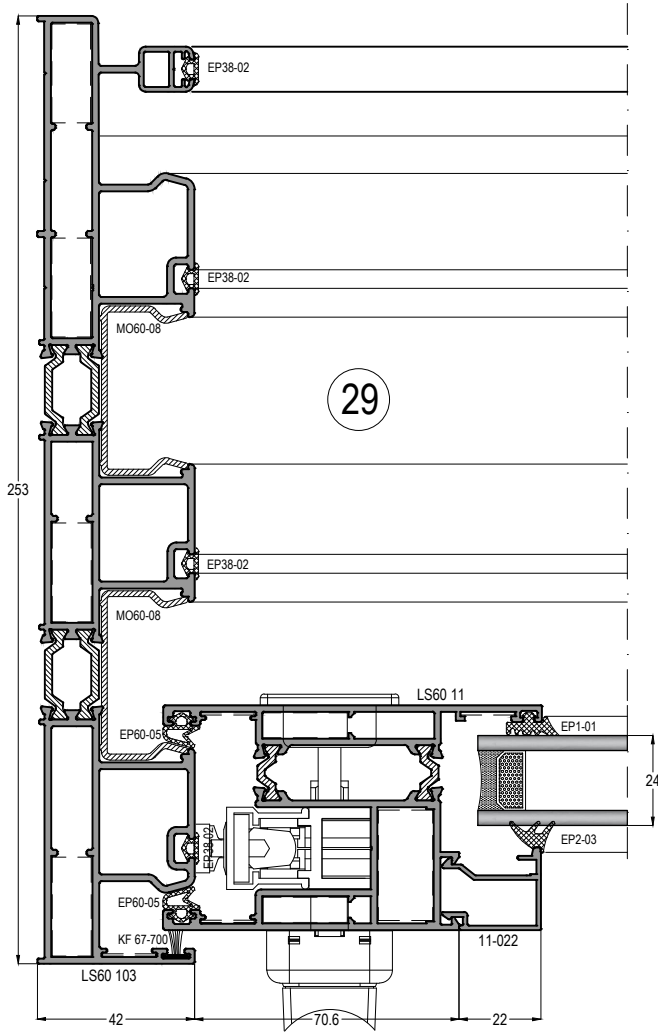

LS60 103 KASA DETAYLARI FRAME DETAILS - LS60 103

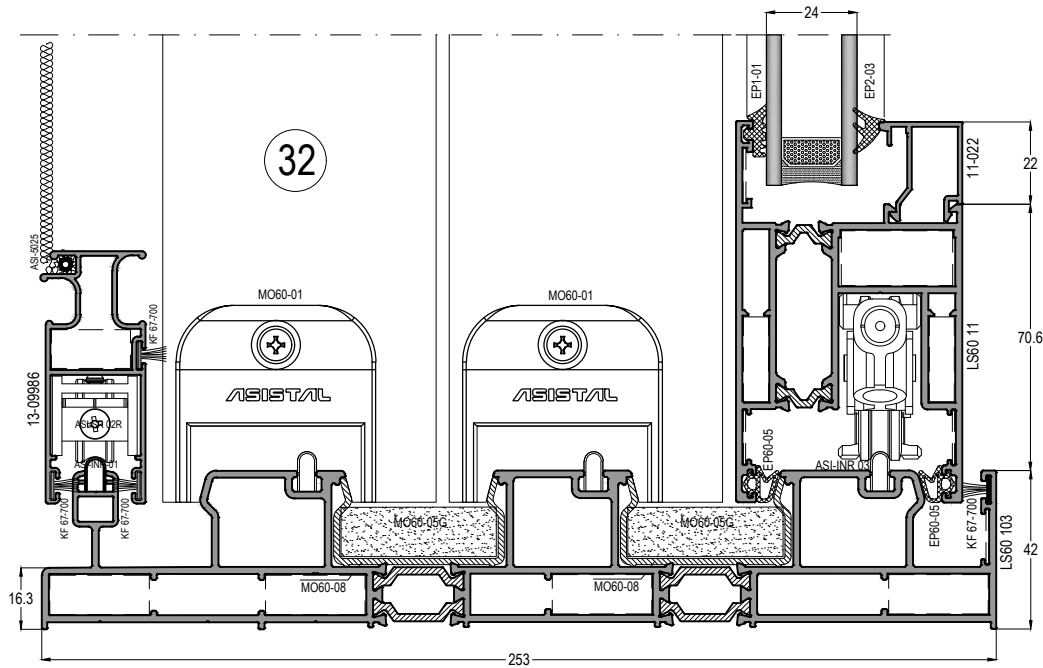
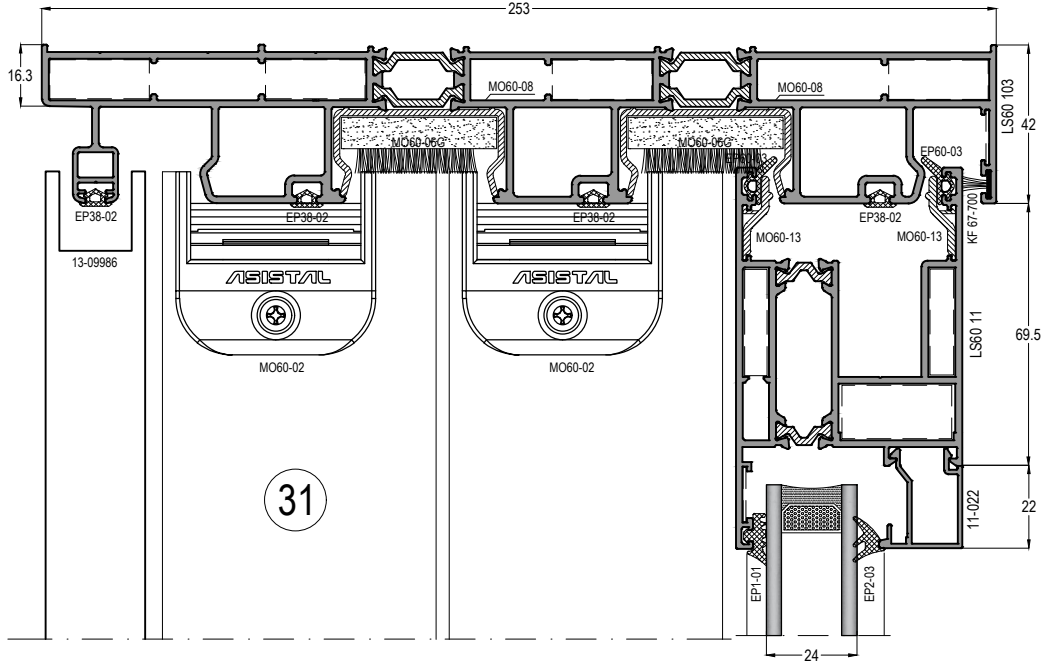
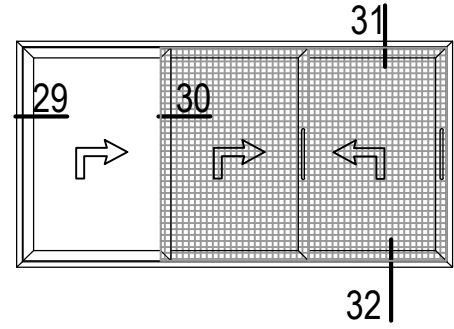

HAREKETLİ KANATDAN SABİT YAPILMASI

SLIDING SASH CONVERTING TO THE FIXED SASH

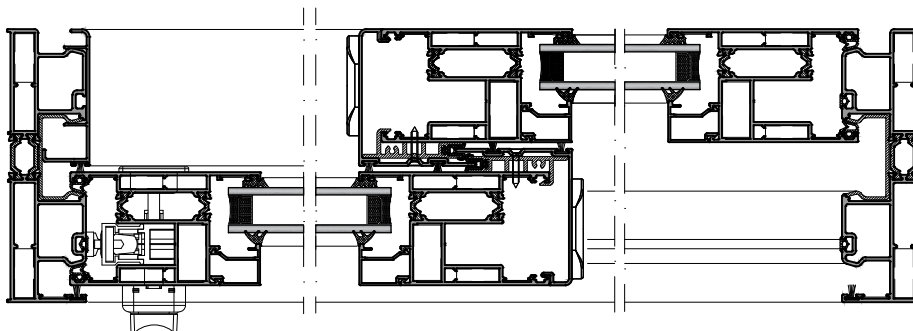
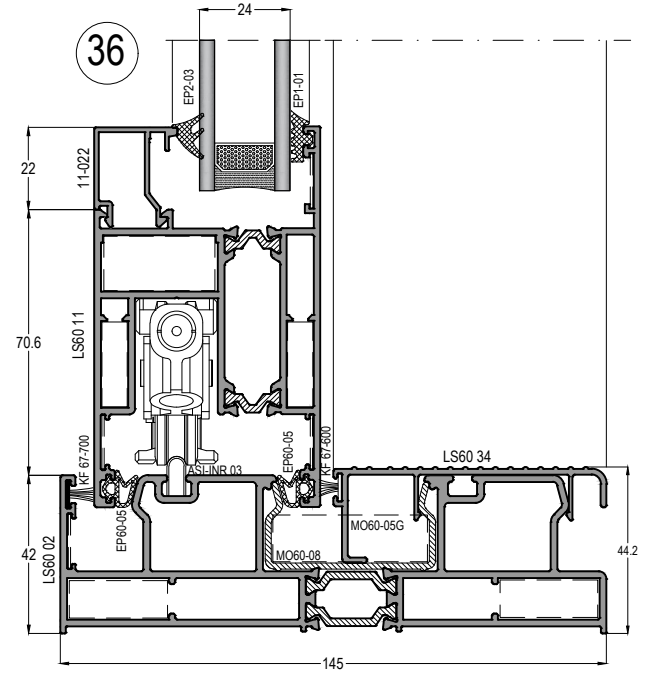
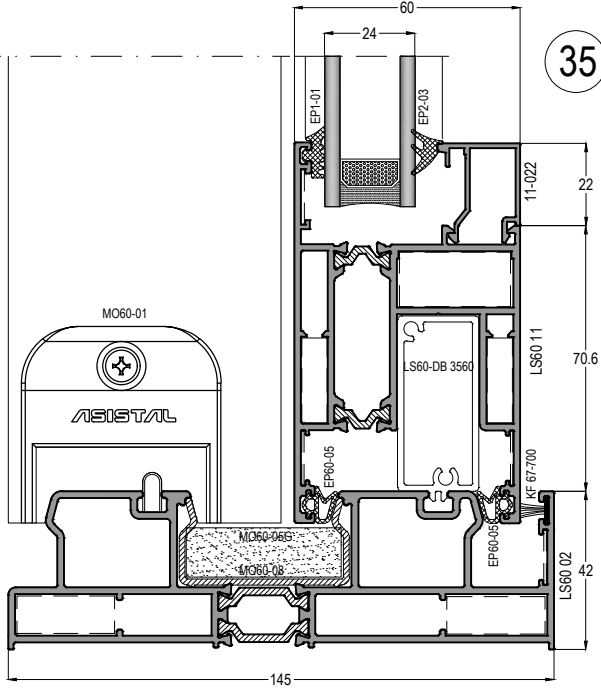
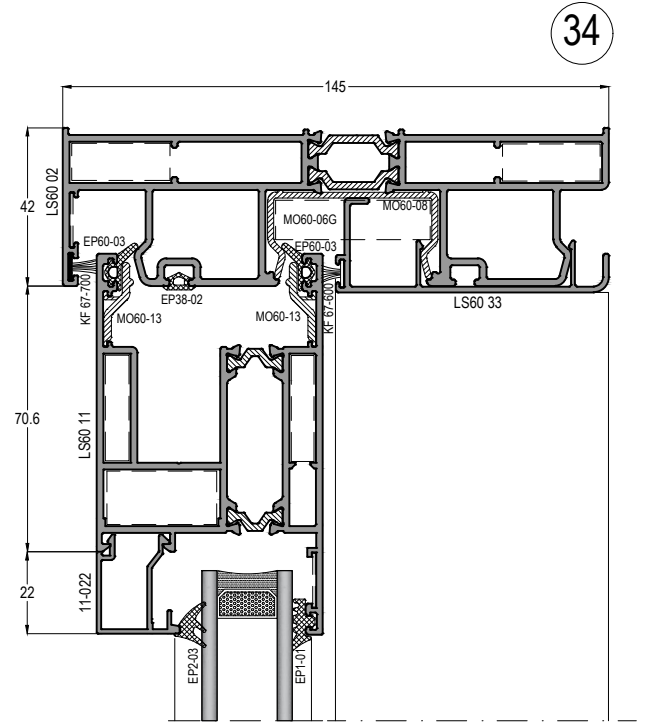
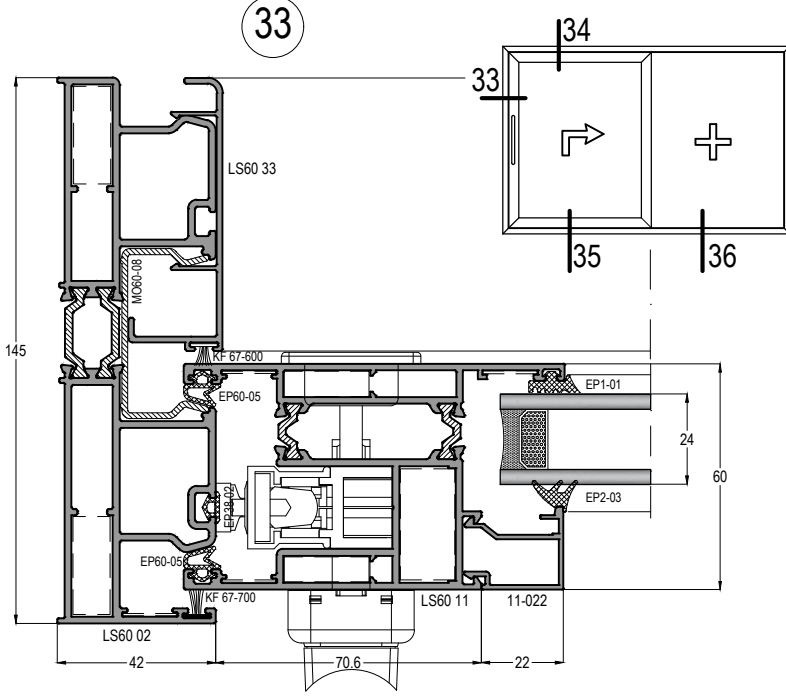

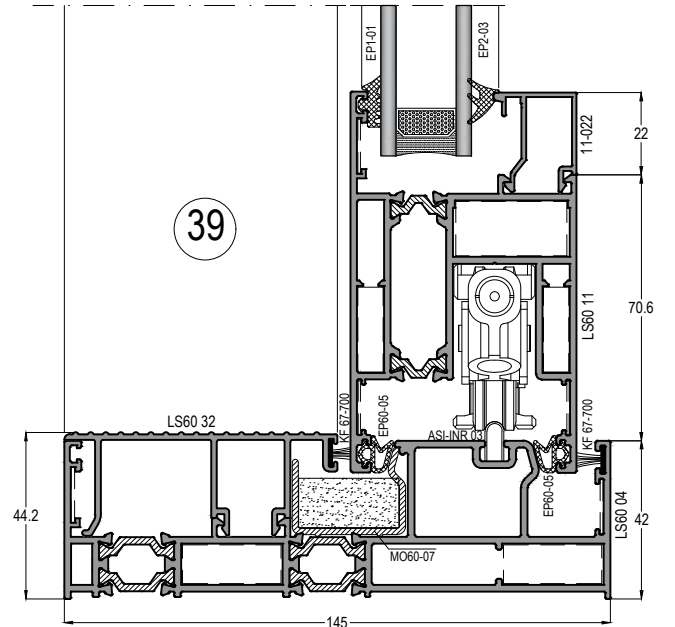
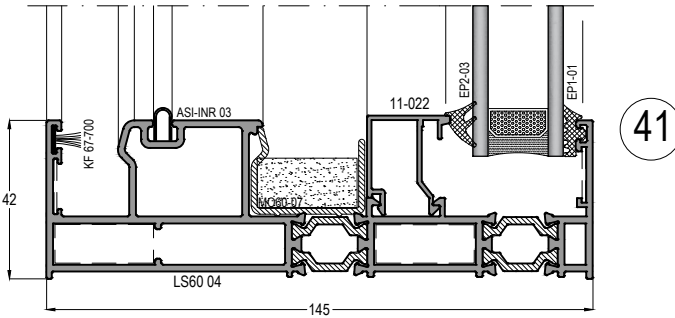
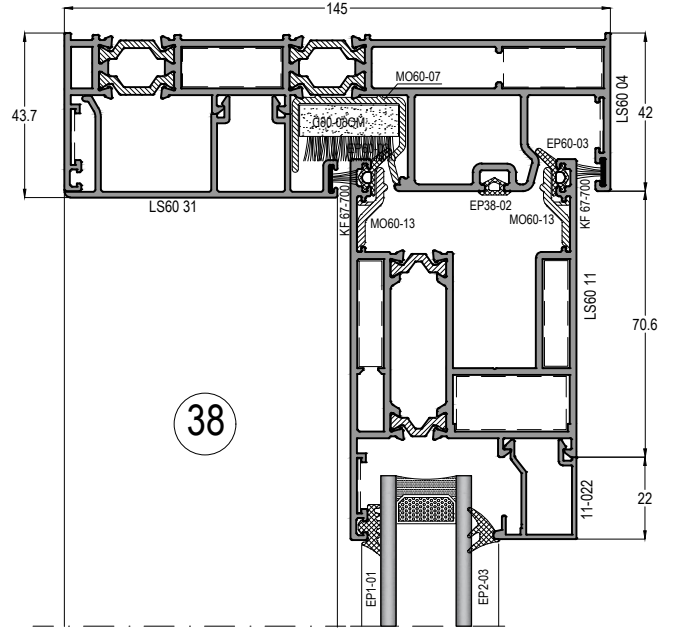
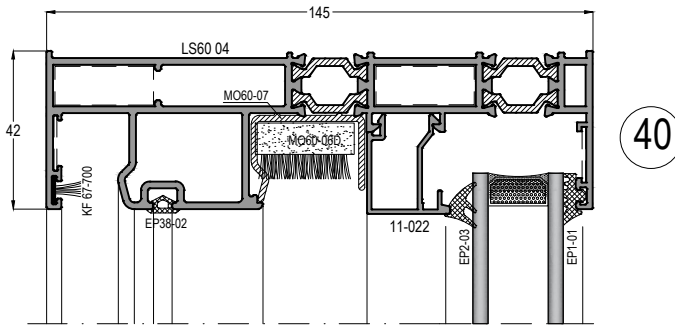
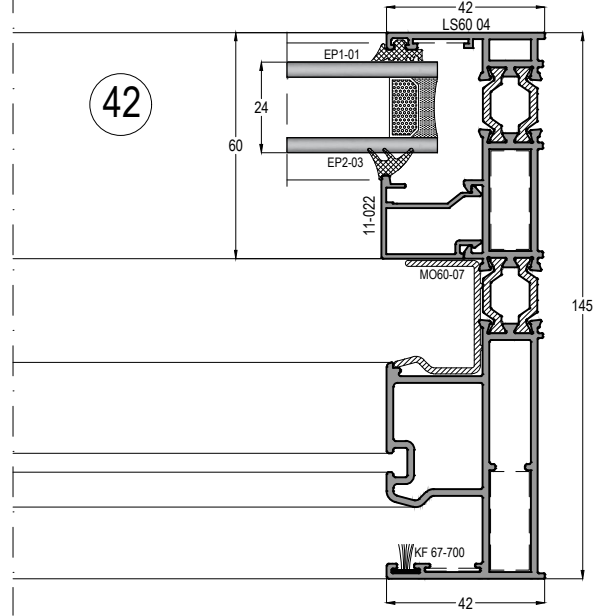
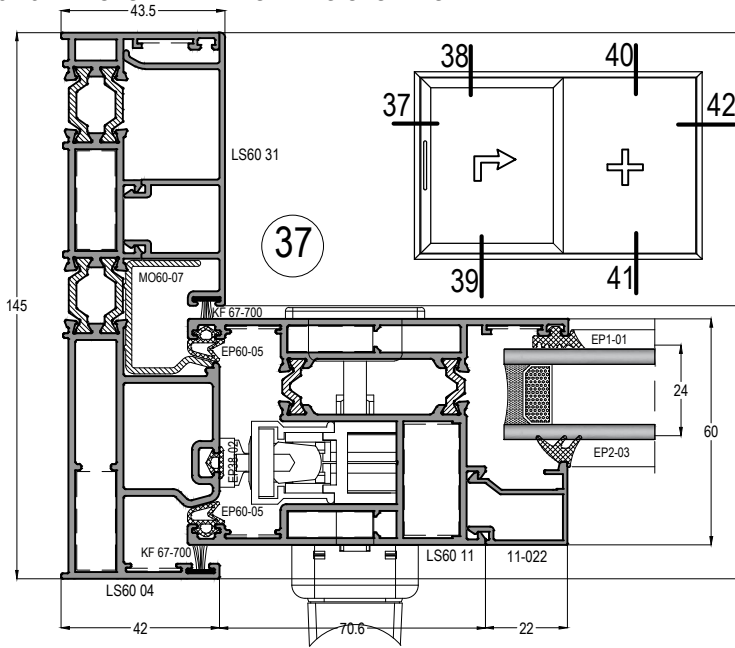
HAREKETLİ KANADI İÇERİDE OLAN MONORAIL SİSTEM
MONORAIL SYSTEM WITH SLIDING SASH INSIDE

NOT: LS60 04 KASA, CAM KALINLIĞI 24mm DEN FAZLA OLAN CAMLARIN MONTAJI İÇİN UYGUN DEĞİLDİR

LS60 04 CASE, NOT SUITABLE FOR INSTALLATION
FOR GLASSES WITH GLASS THICKNESS MORE THAN 24mm

HAREKETLİ KANADI DIŞARIDA OLAN MONORAİL SİSTEM
MONORAIL SYSTEM WITH SLIDING SASH OUTSIDE

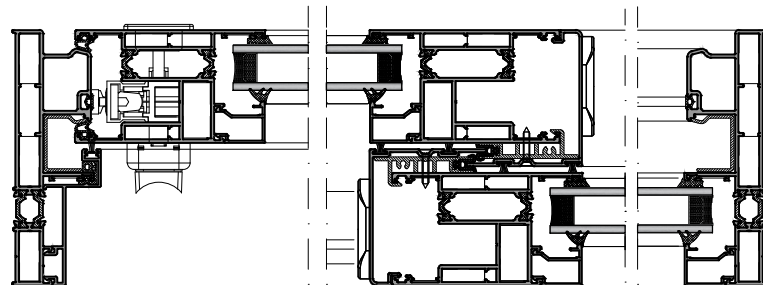
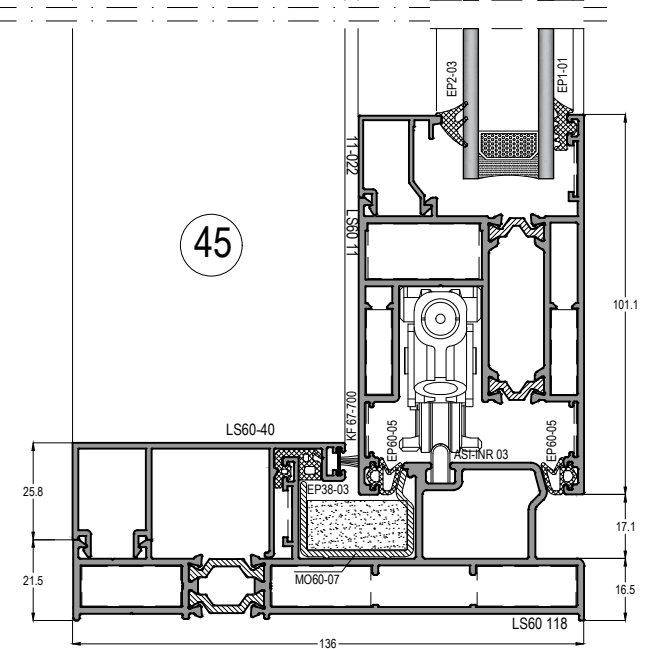
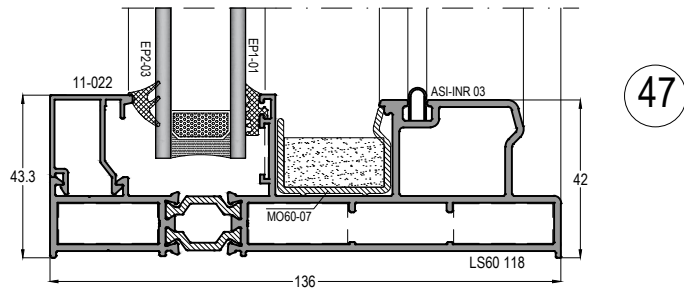
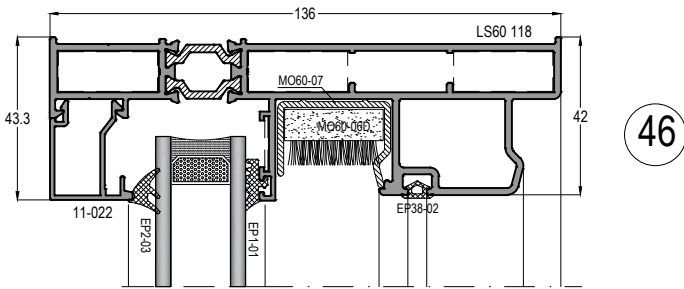
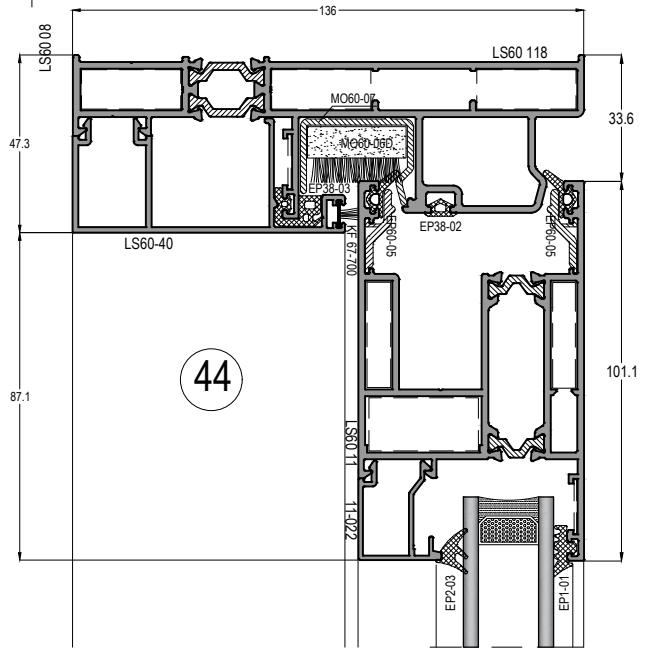
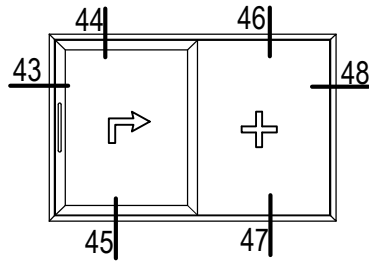
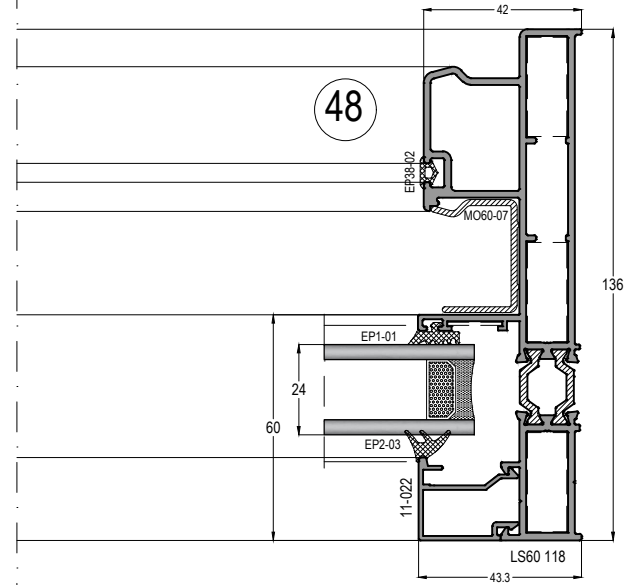
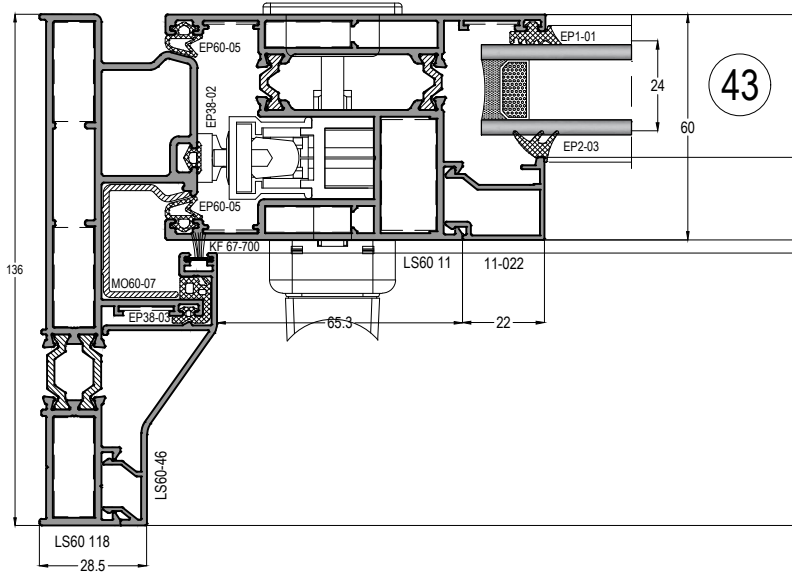

LS60

YALITIMLI KALDIR-SÜR SİSTEM
THERMAL LIFT&SLIDE SYSTEM

ASISTAL

HAREKETLİ KANADI DIŞARIDA OLAN MONORAIL SİSTEM DAR KENET
NARROW MONORAIL SYSTEM WITH SLIDING SASH OUTSIDE

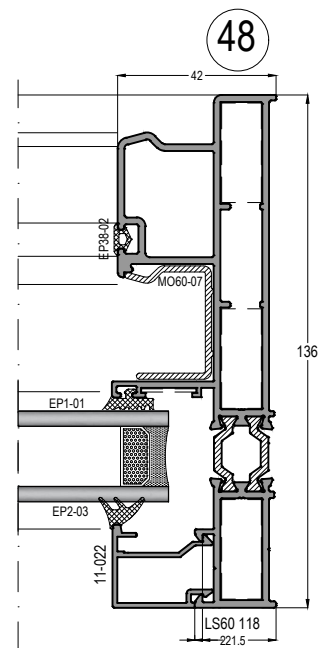
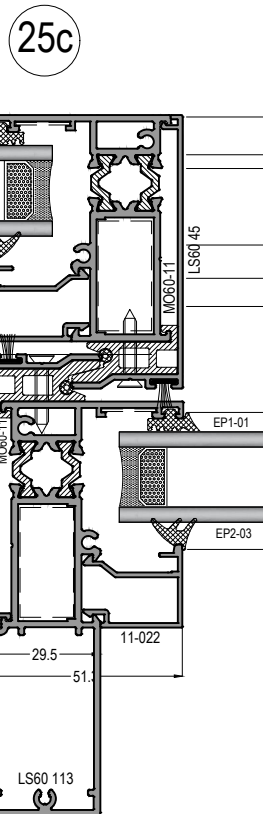
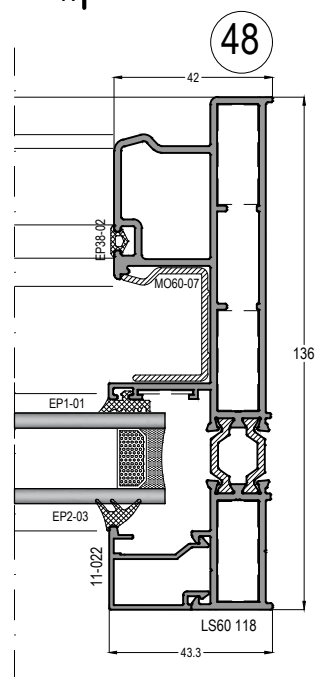
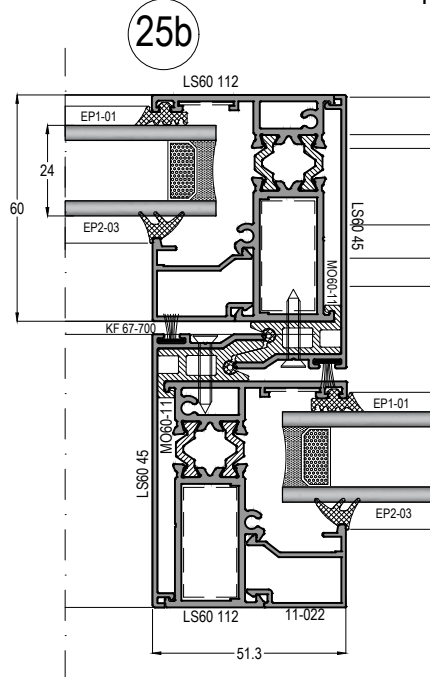
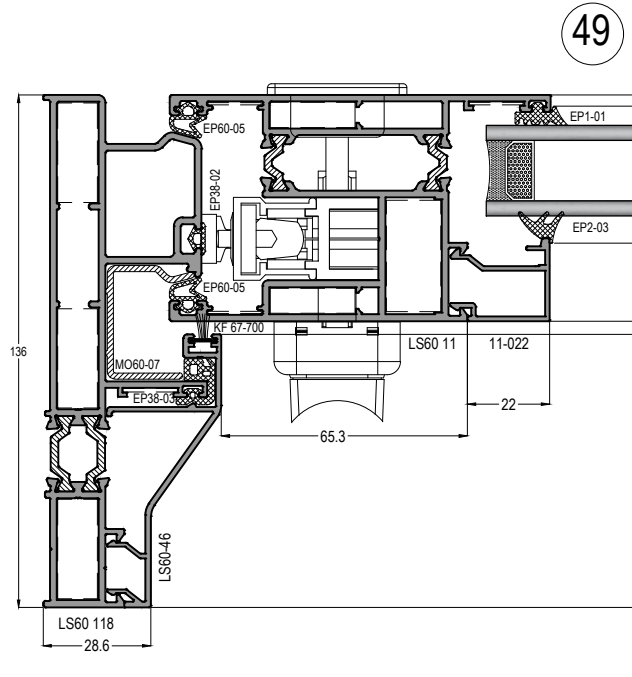
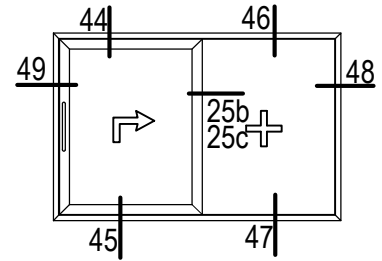

HAREKETLİ KANADI DIŞARIDA OLAN MONORAIL SİSTEM
MONORAIL SYSTEM WITH SLIDING SASH OUTSIDE

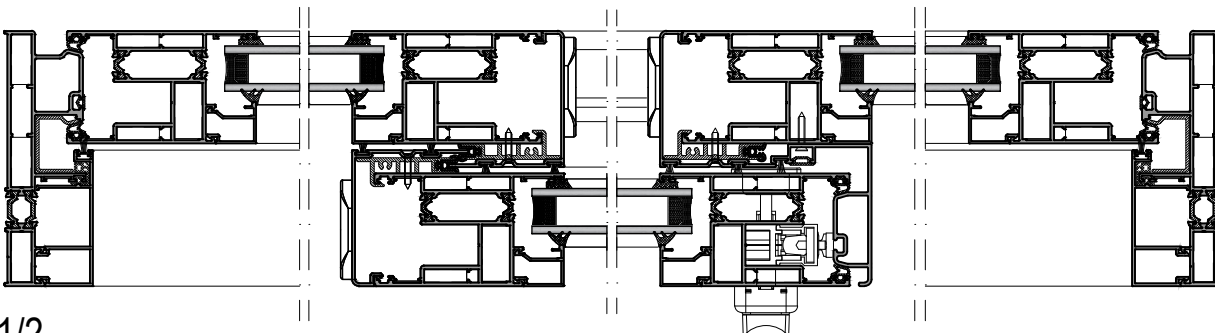
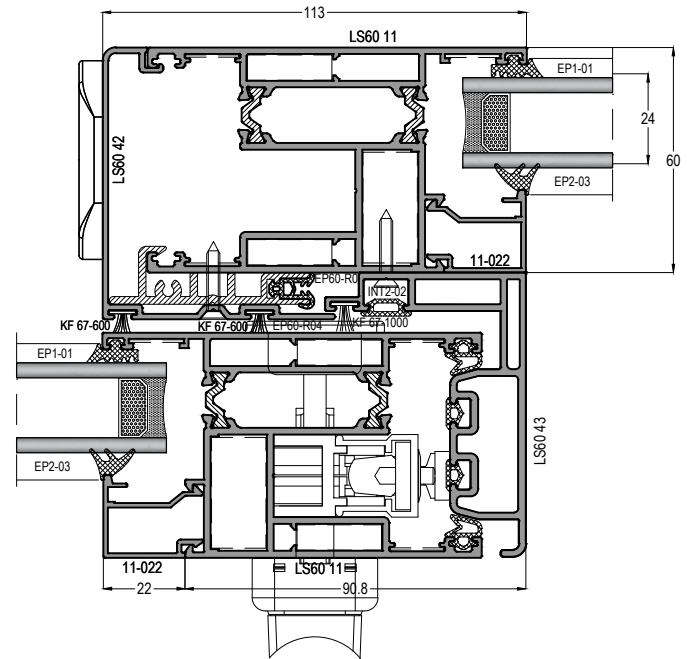
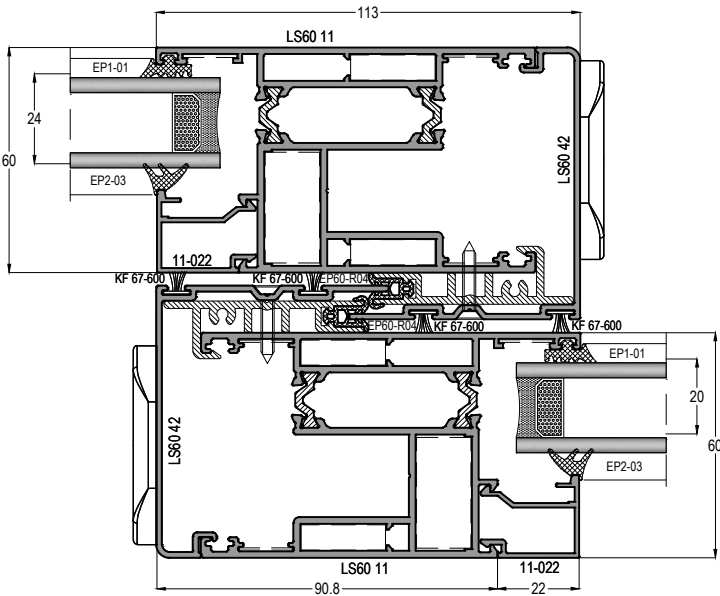
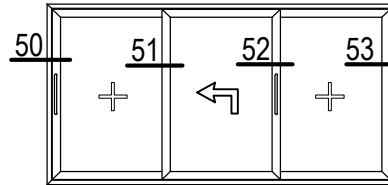
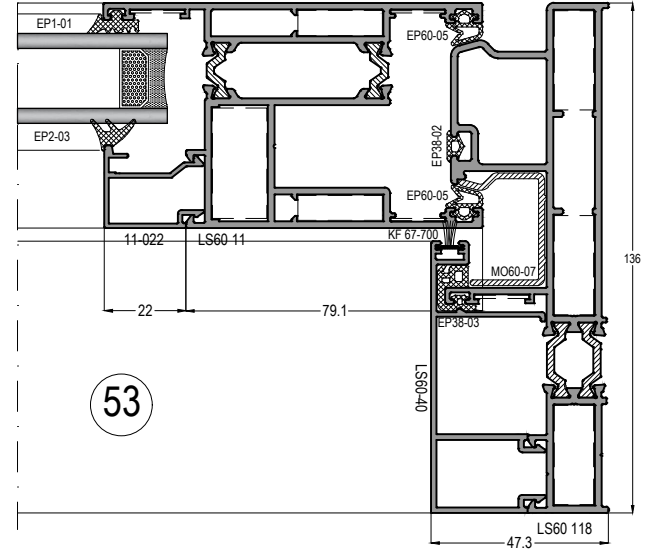
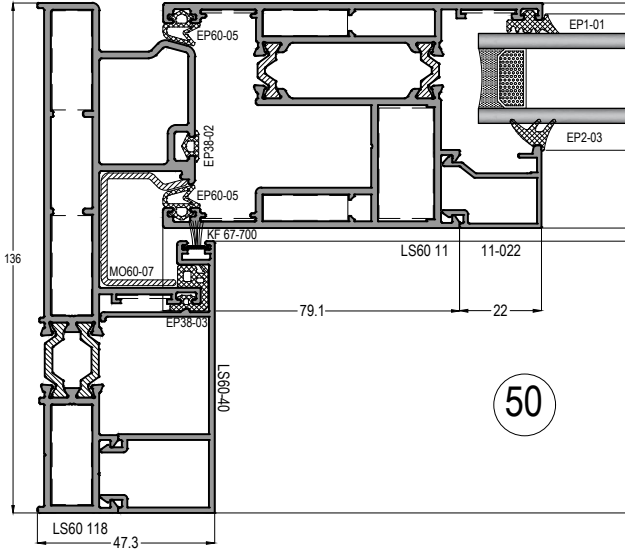

TH62 SİSTEME GEÇİŞ KASASI
TRANSITION FRAME TO TH62 SYSTEM

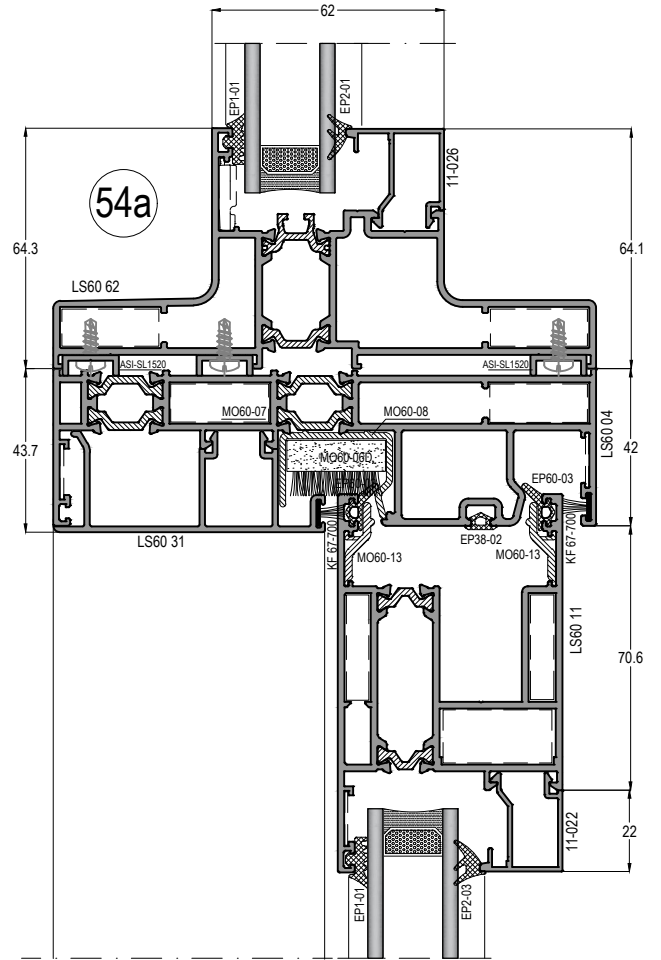
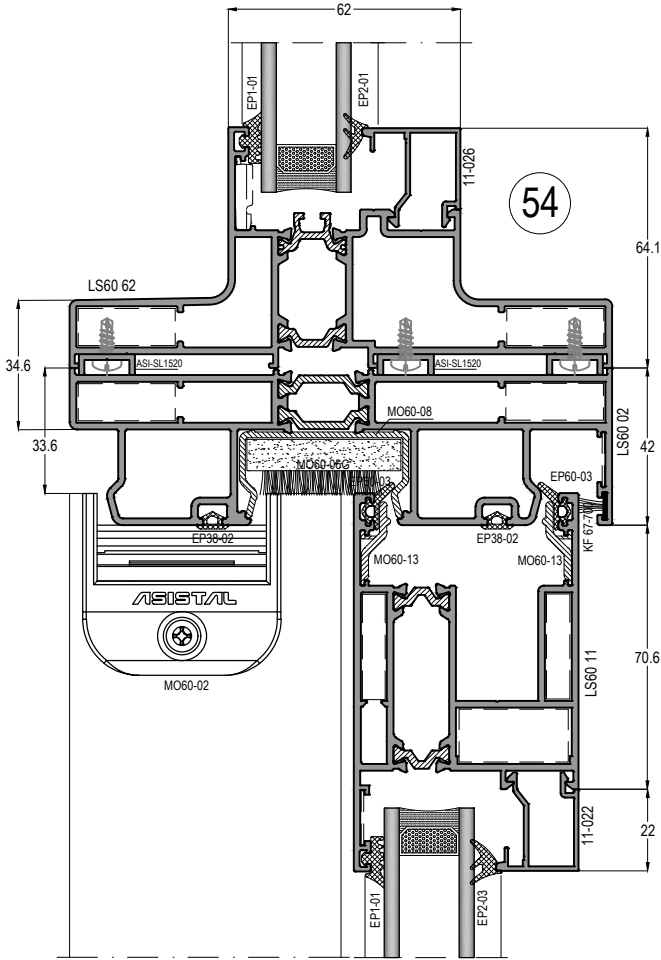
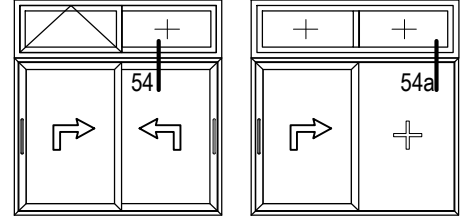

LS60

YALITIMLI KALDIR-SÜR SİSTEM
THERMAL LIFT&SLIDE SYSTEM



NORMAL SÜRME SİSTEM DETAYI - LS60 N NORMAL SLIDING SYSTEM DETAILS

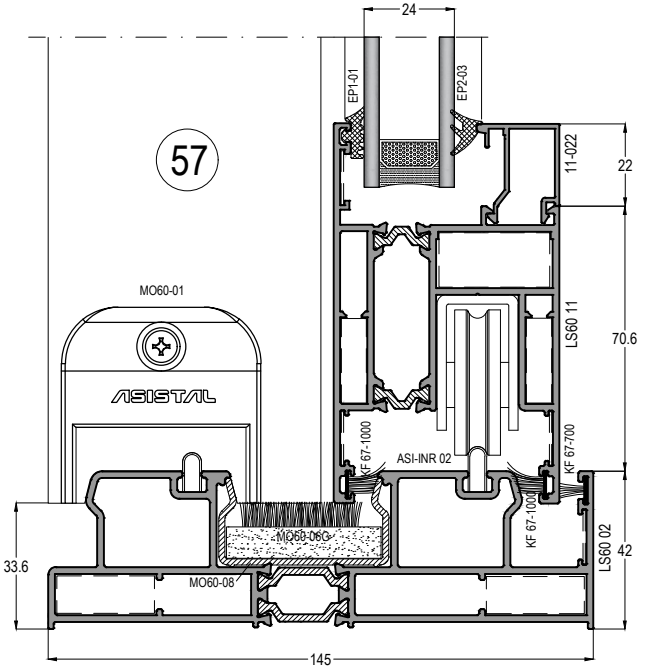
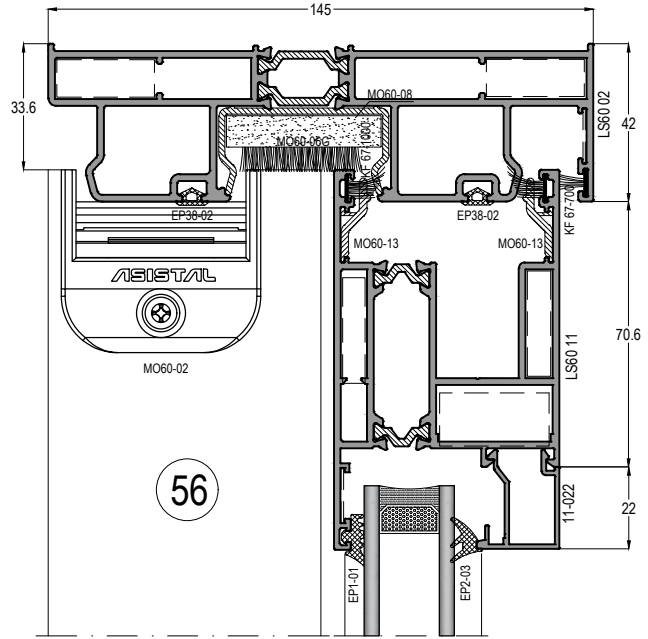
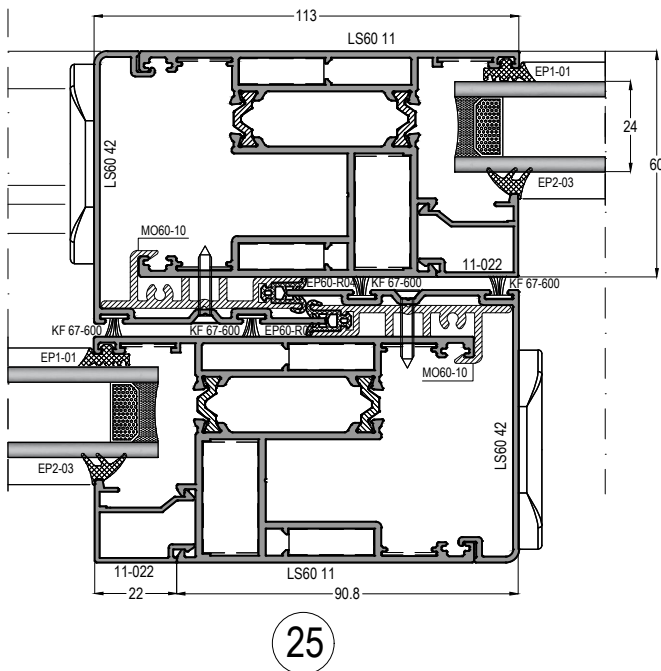
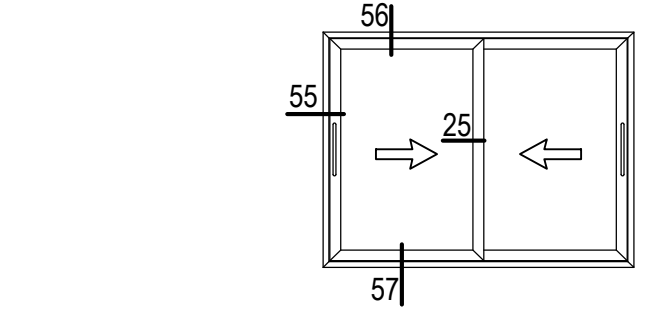
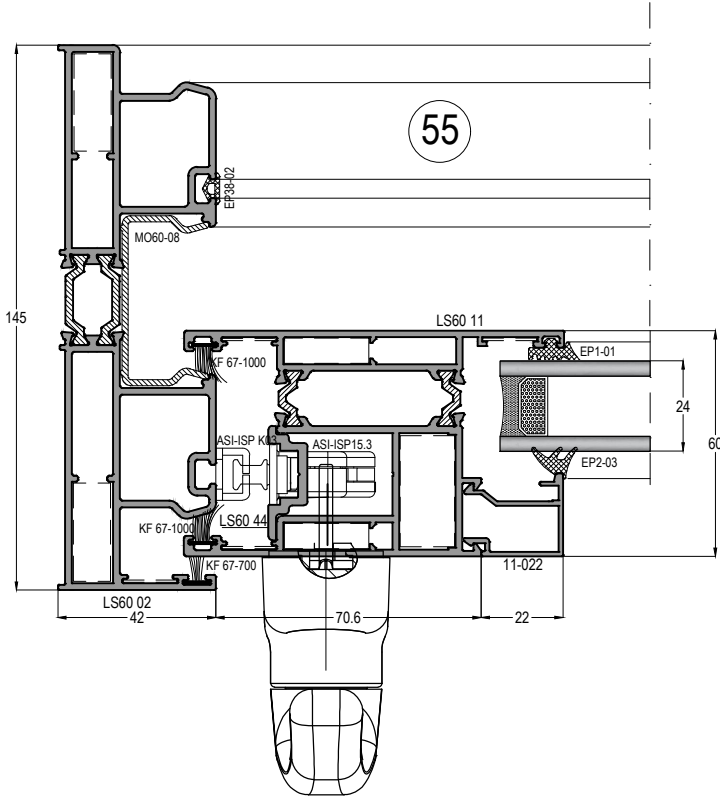

25

57

LS60

YALITIMLI KALDIR-SÜR SİSTEM
THERMAL LIFT&SLIDE SYSTEM

ASISTAL

YAĞMUR SUYU TAHLİYE DETAYLARI / DRENAJ RAIN WATER DRAINAGE DETAILS

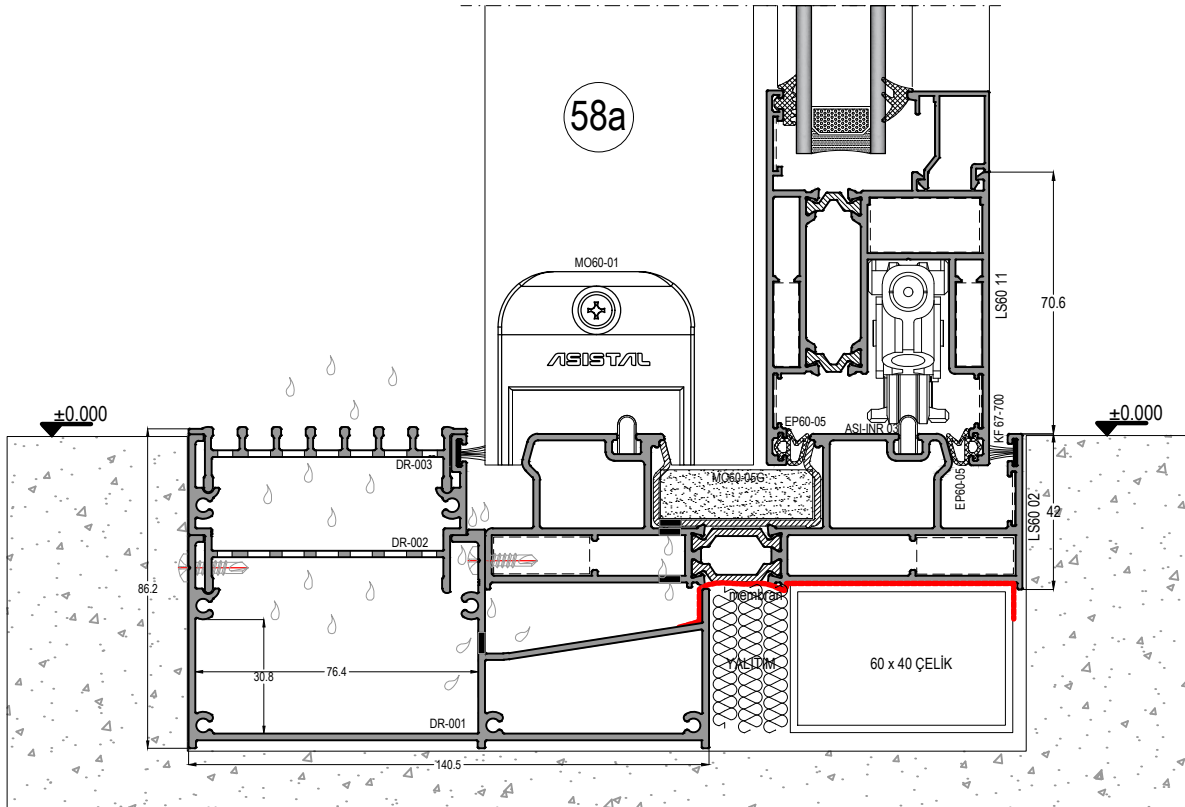
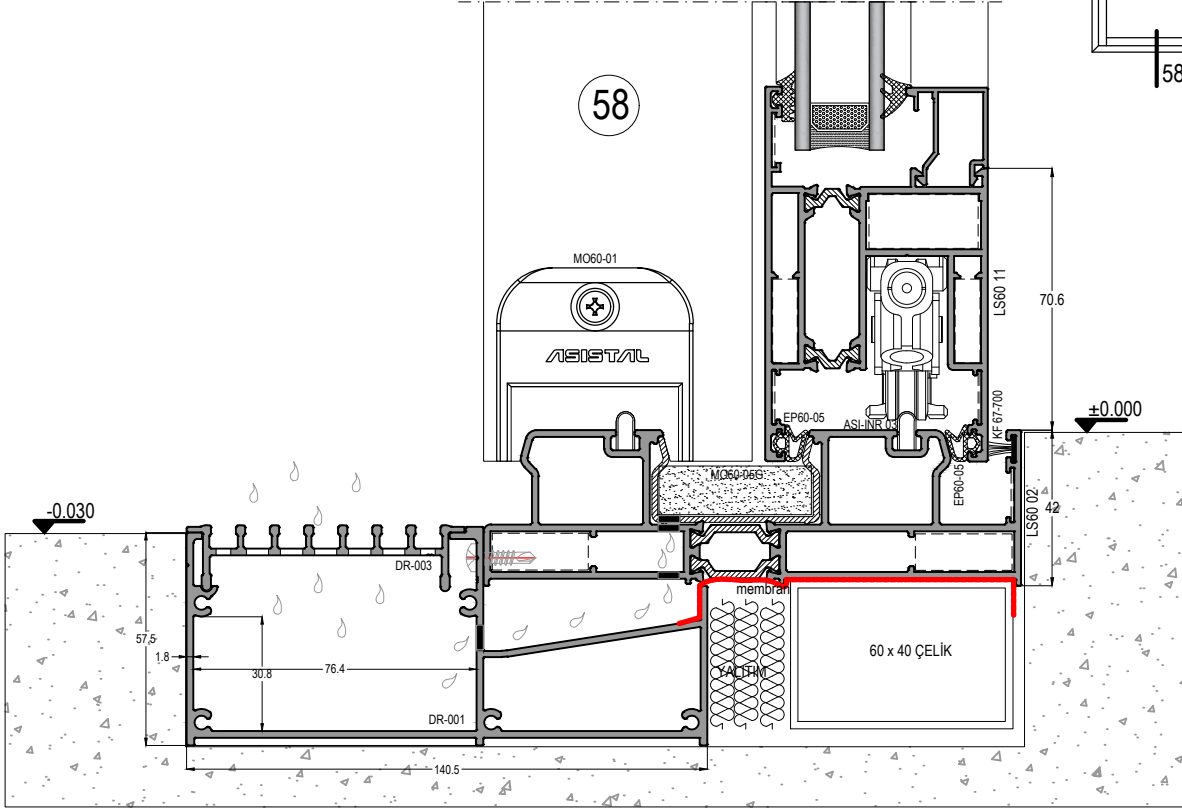
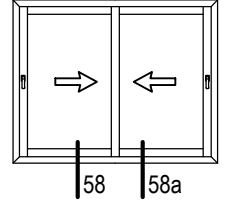

LS60 102 KASA DRENAJ DETAYLARI

FRAME DETAILS for DRANAIGE - LS60 102

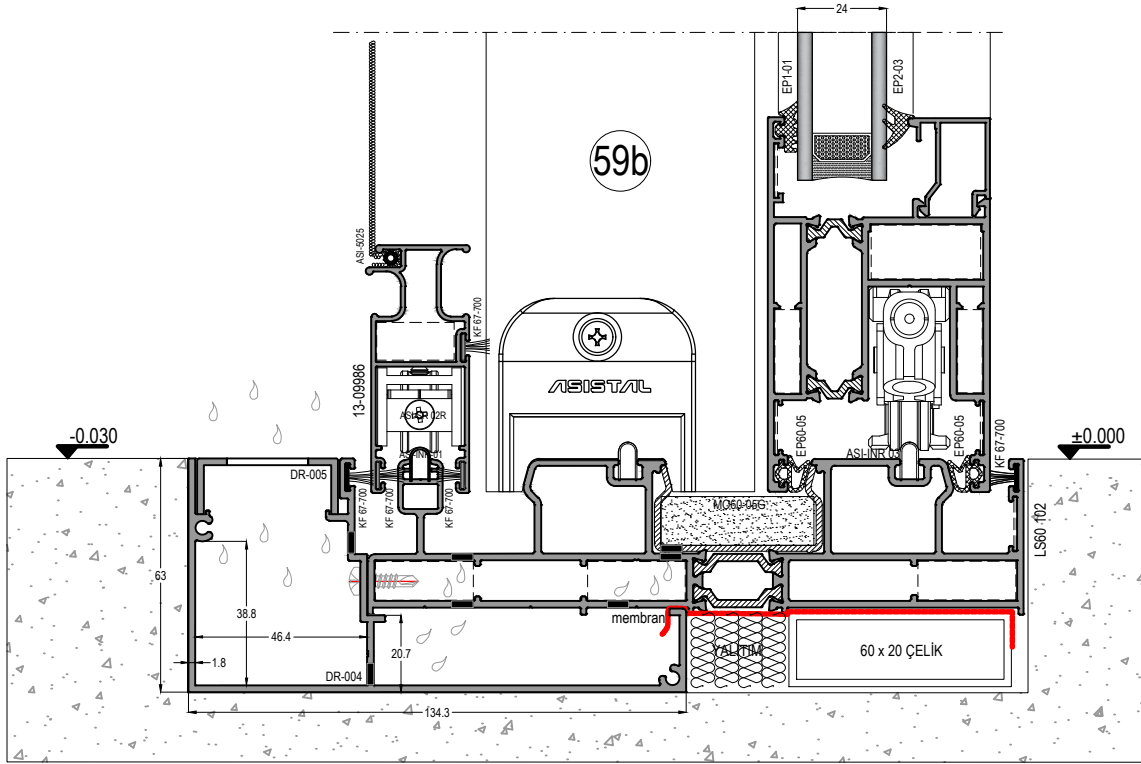
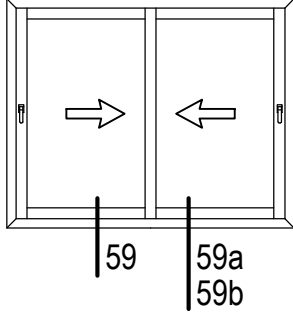

LS60 103 KASA DRENAJ DETAYLARI FRAME DETAILS for DRANAIGE - LS60 103

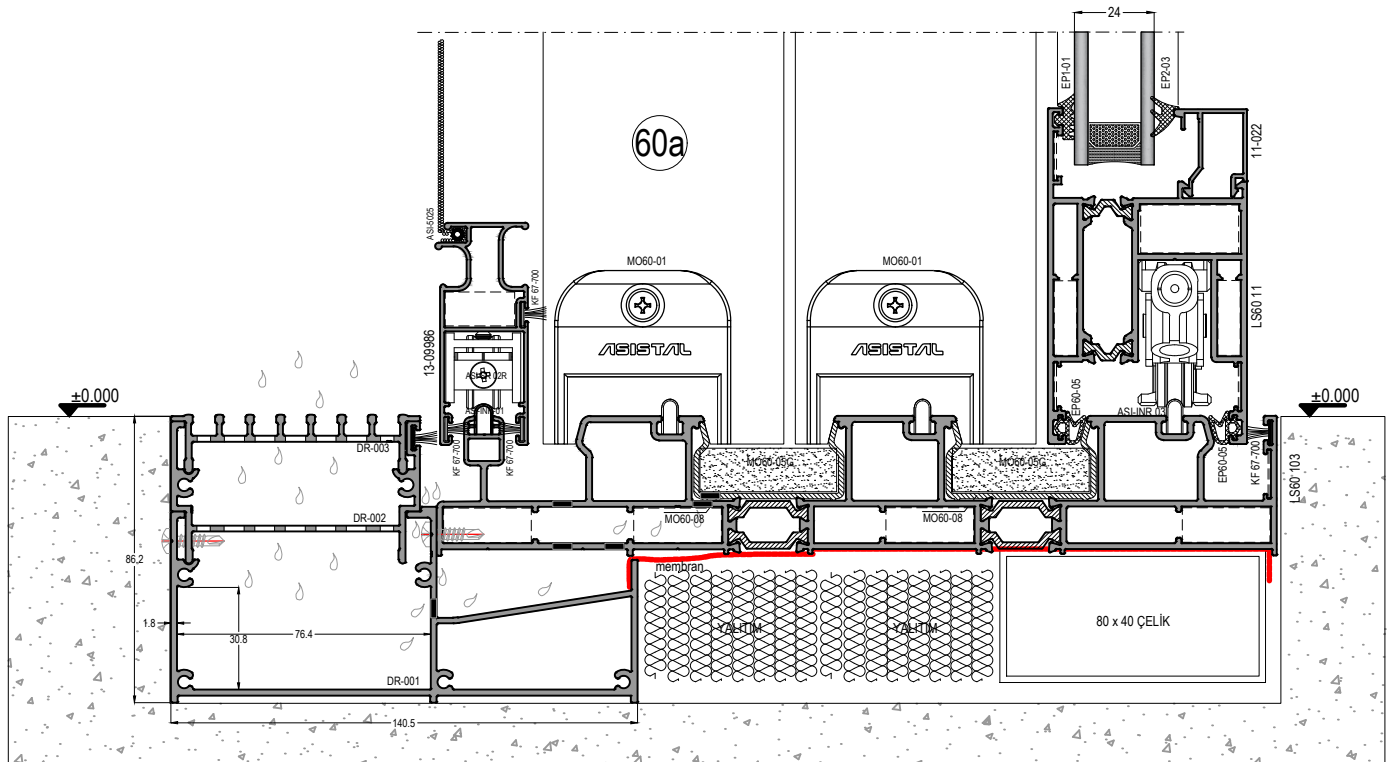
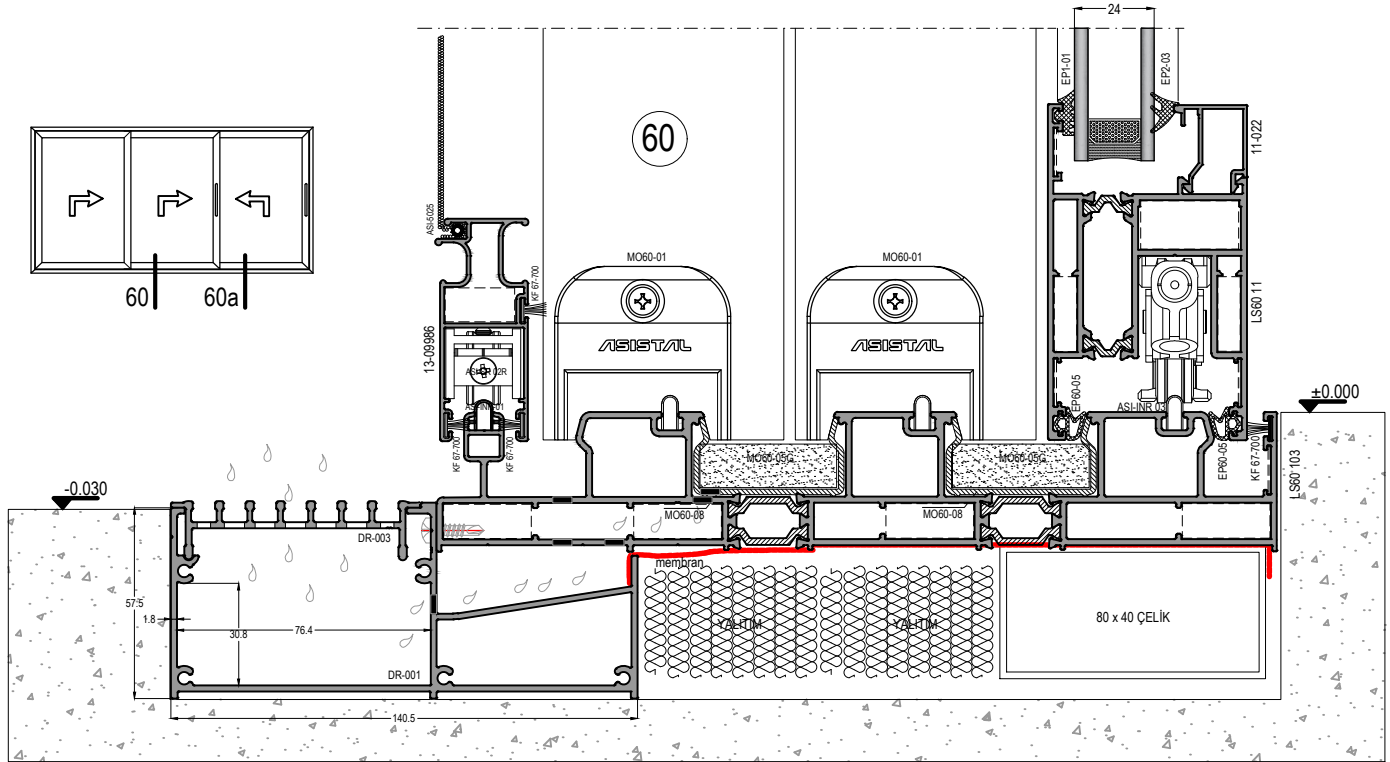

YAĞMUR SUYU TAHLİYE DETAYLARI / DRENAJ

RAIN WATER DRAINAGE DETAILS

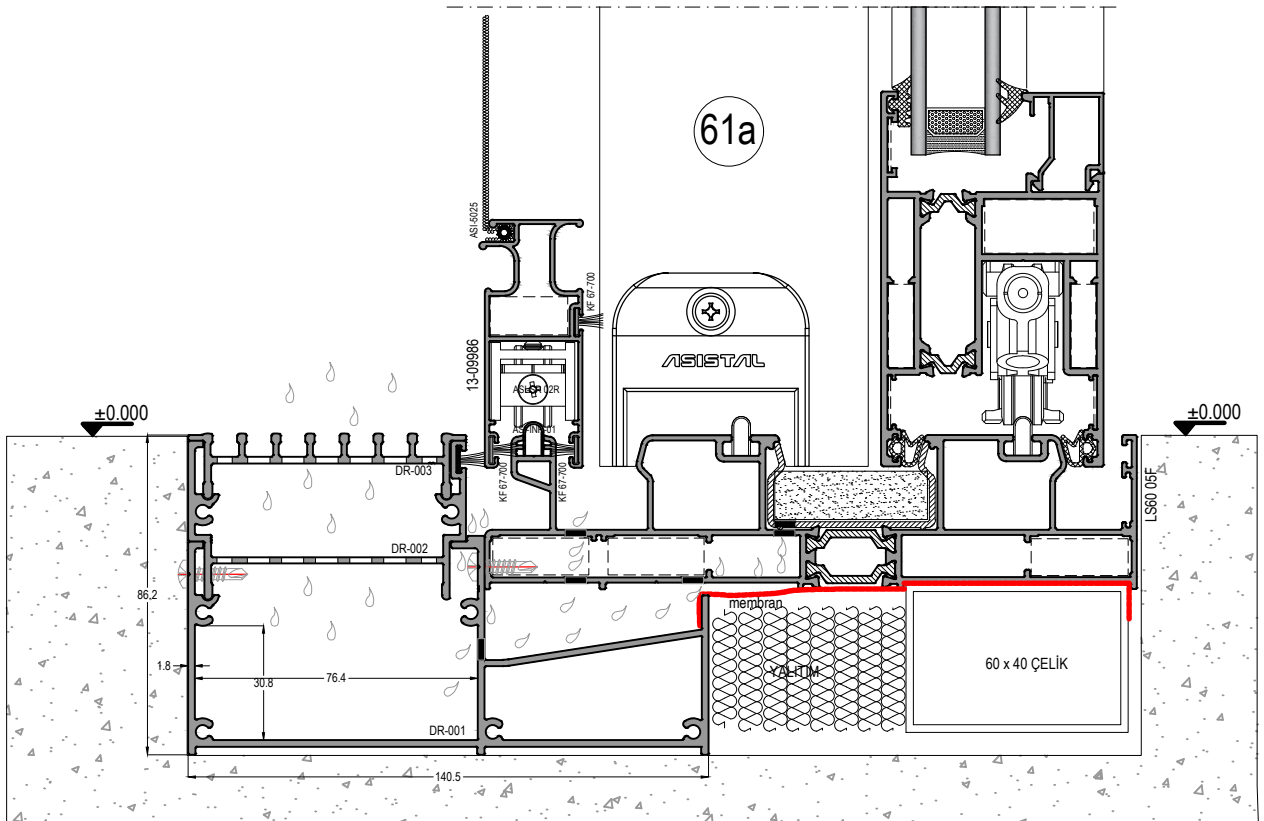
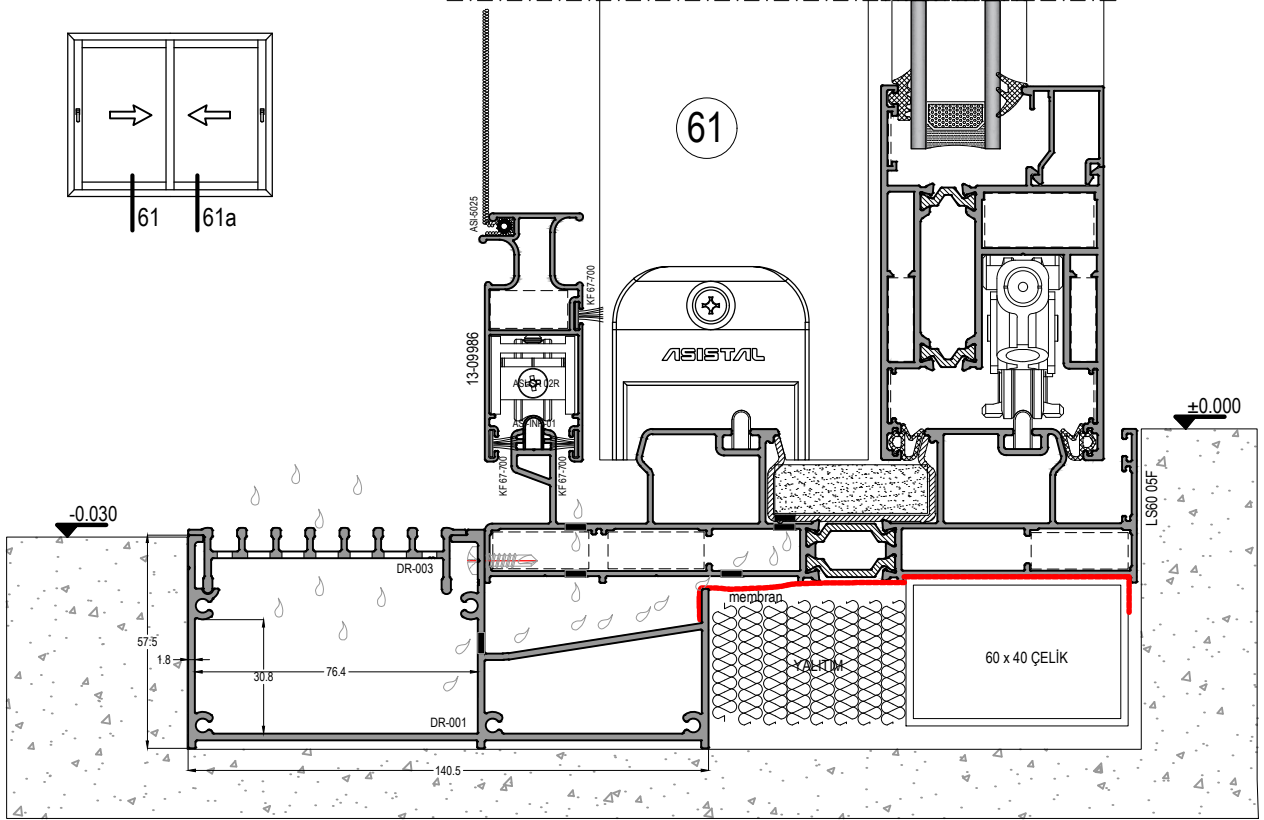

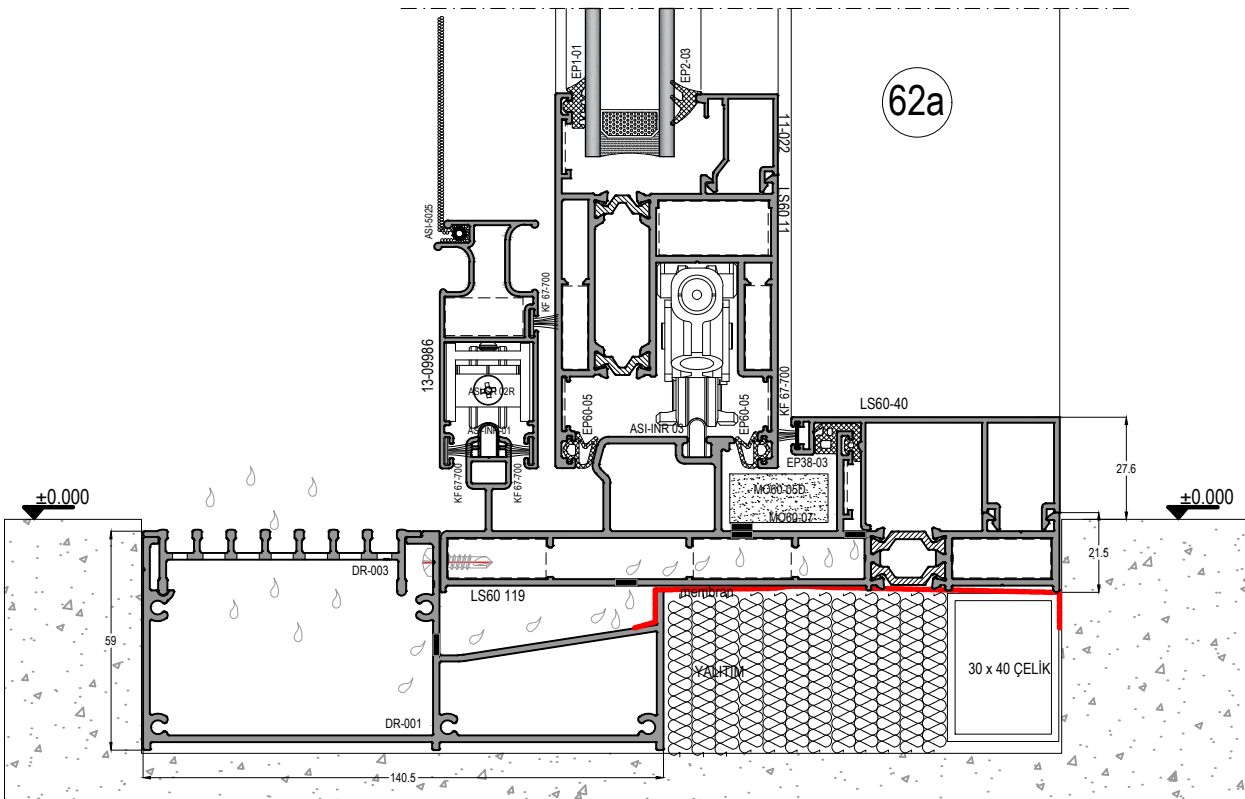
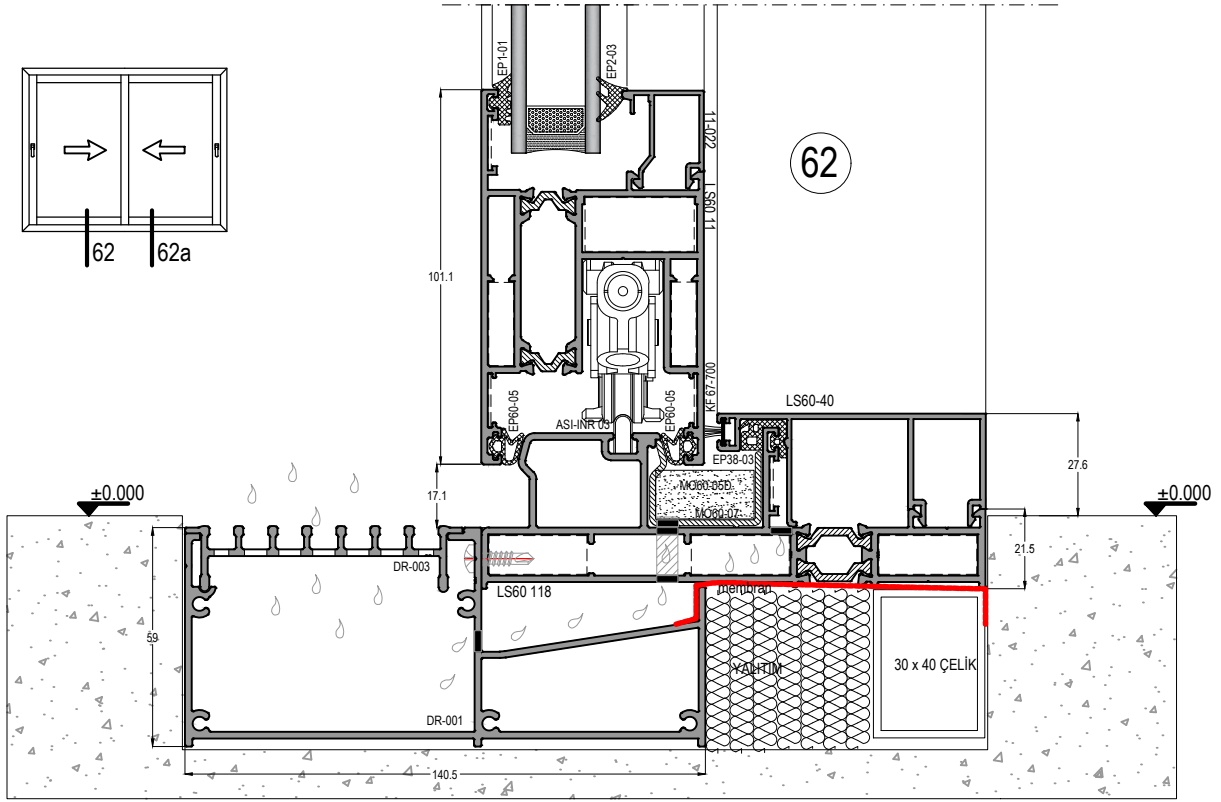
YAĞMUR SUYU TAHLİYE DETAYLARI / DRENAJ
RAIN WATER DRAINAGE DETAILS

YAĞMUR SUYU TAHLIYE DETAYLARI / DRENAJ
RAIN WATER DRAINAGE DETAILS