

**G130T**

ISICAMLI GIYOTIN SÜRME CAM BALKON SİSTEMİ  
VERTICAL SLIDING GLASS BALCONY SYSTEM WITH THERMAL GLASS

**ASISTAL**

**KESİM VE MONTAJ**  
*CUTTING & ASSEMBLY*

# G130T

ISICAMLI GIYOTIN SÜRME CAM BALKON SİSTEMİ  
VERTICAL SLIDING GLASS BALCONY SYSTEM WITH THERMAL GLASS

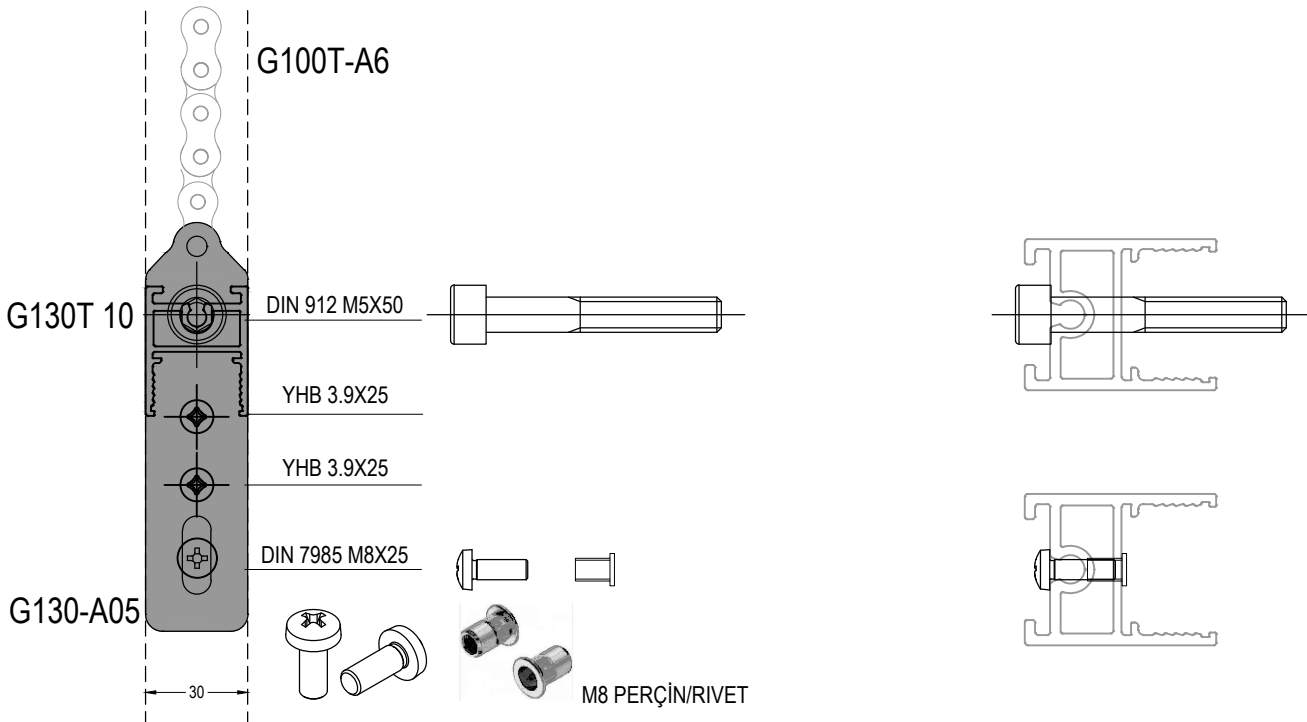
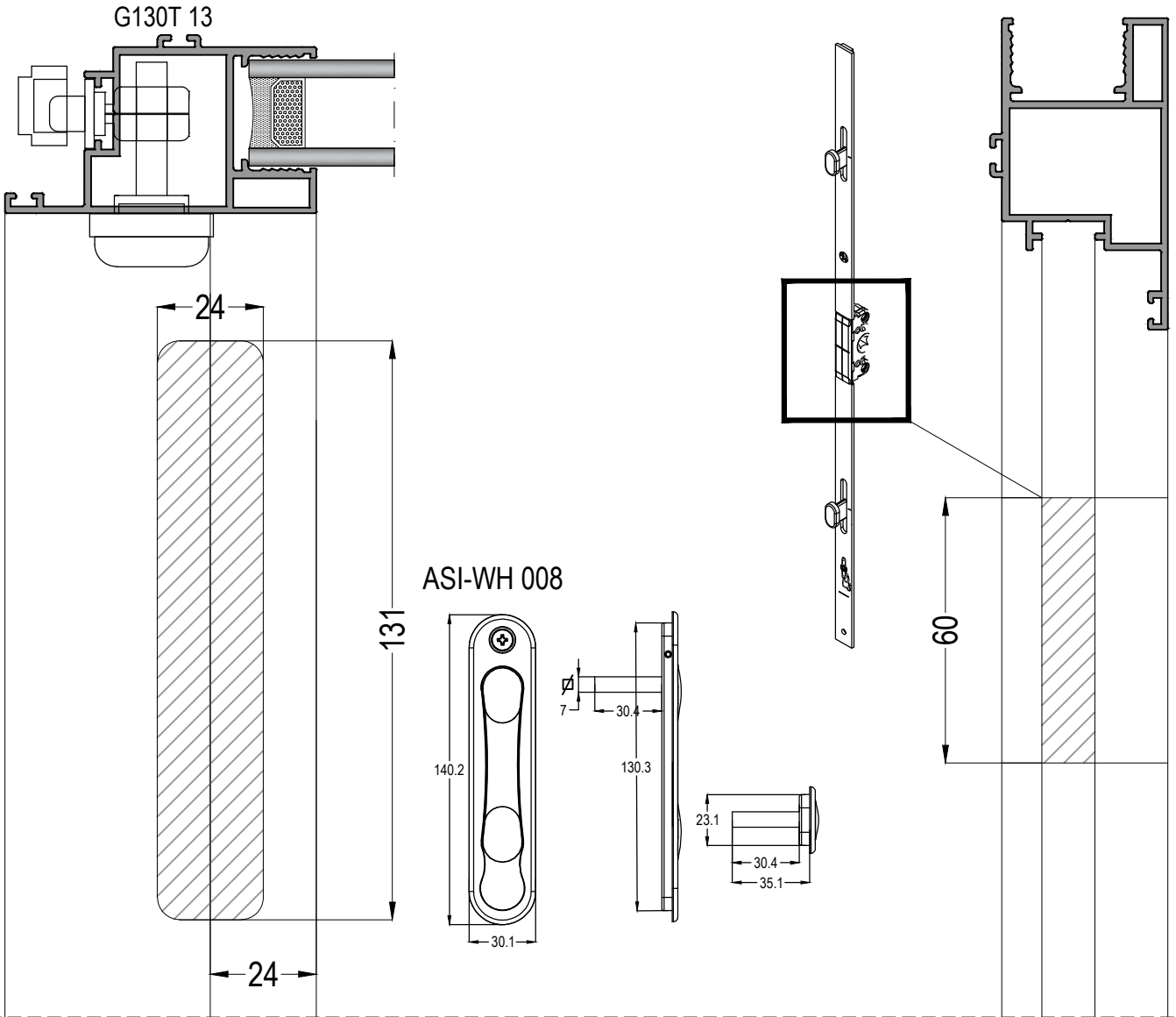

# G130T

ISICAMLI GIYOTIN SÜRME CAM BALKON SİSTEMİ  
VERTICAL SLIDING GLASS BALCONY SYSTEM WITH THERMAL GLASS

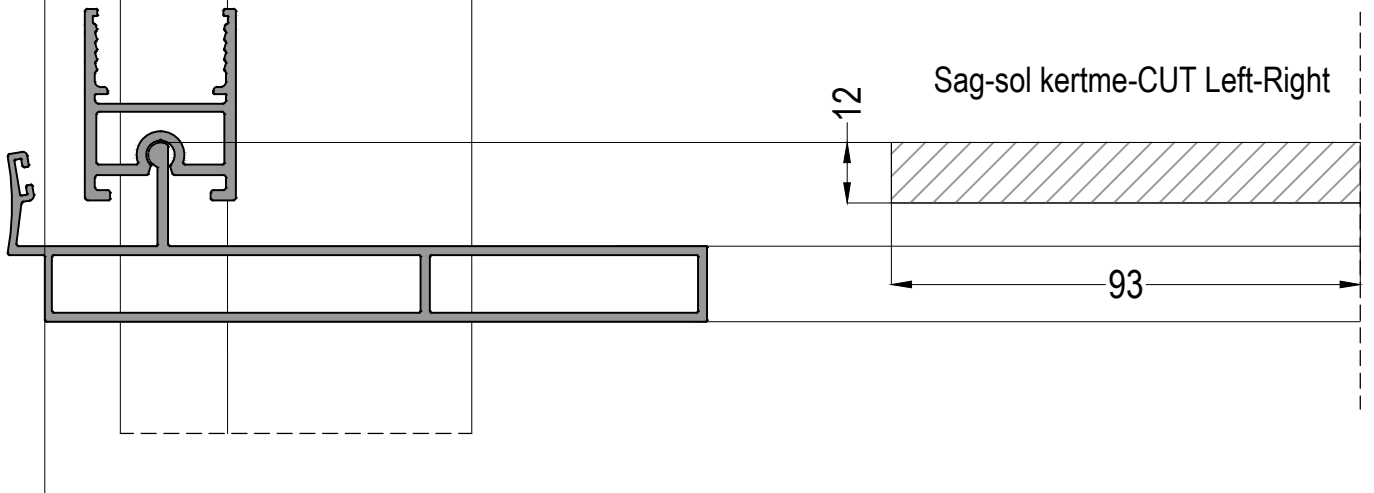
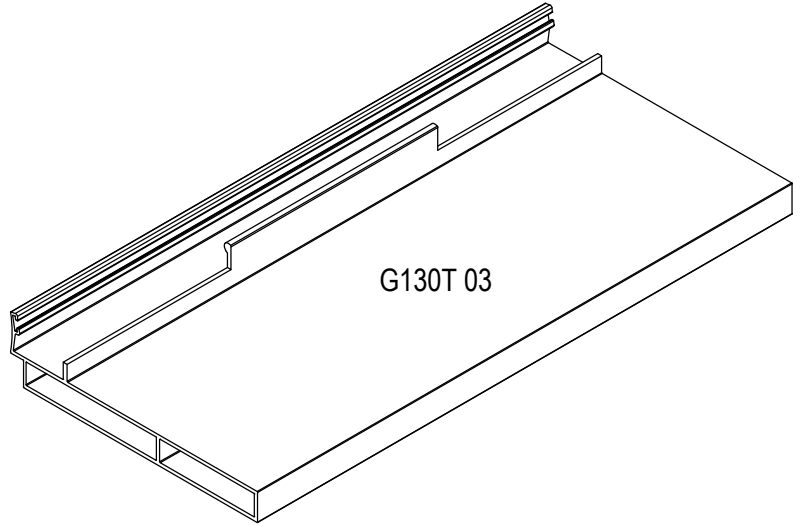
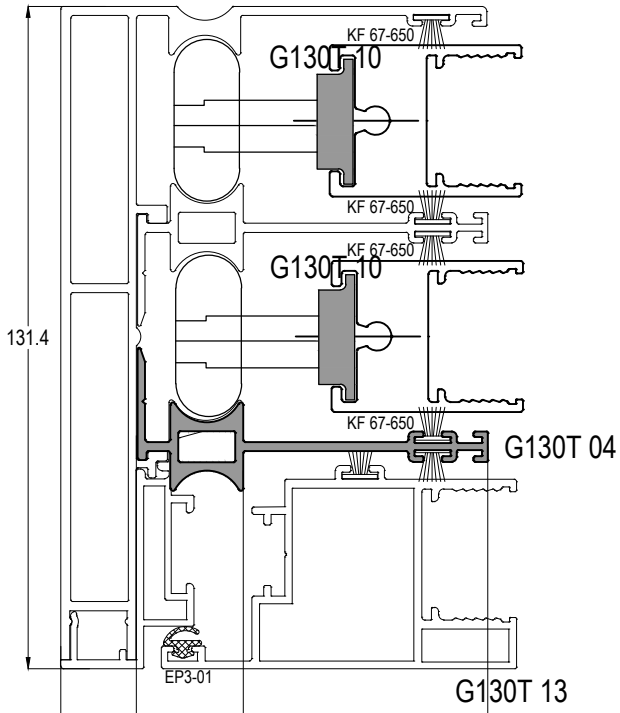

# G130T

ISICAMLI GIYOTİN SÜRME CAM BALKON SİSTEMİ

VERTICAL SLIDING GLASS BALCONY SYSTEM WITH THERMAL GLASS

**ASISTAL**

DIN 934 M8



DIN 7991 M8X16

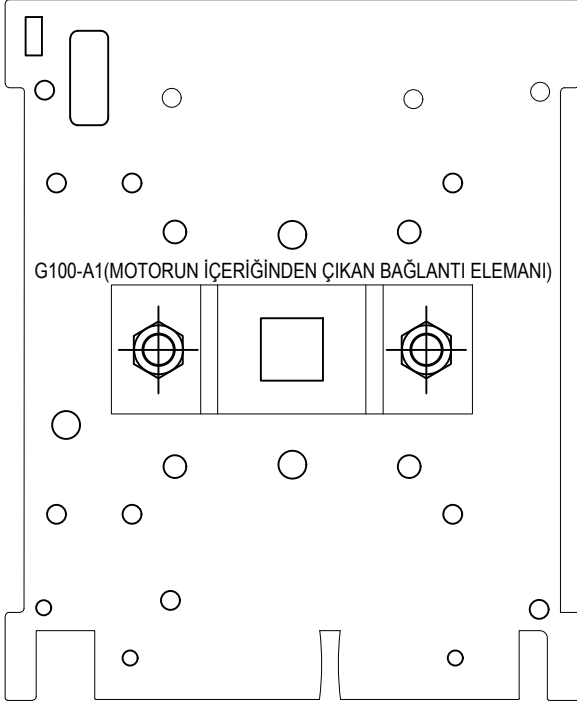

Şase/duvar motor kapağı

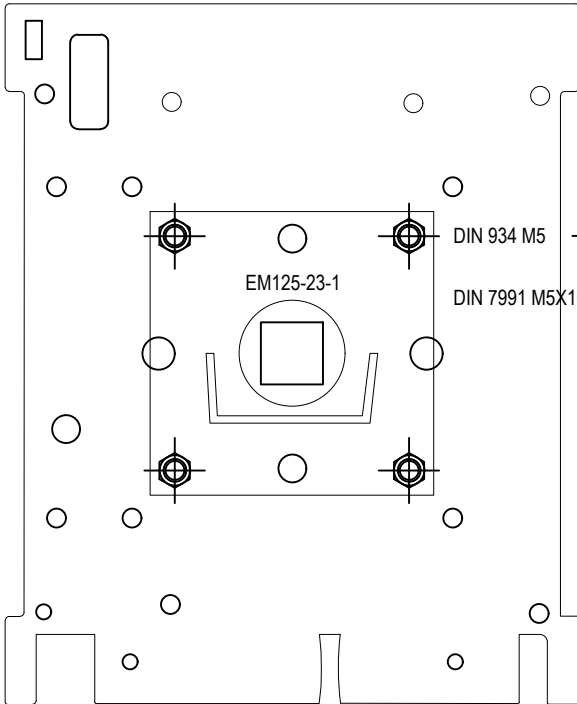
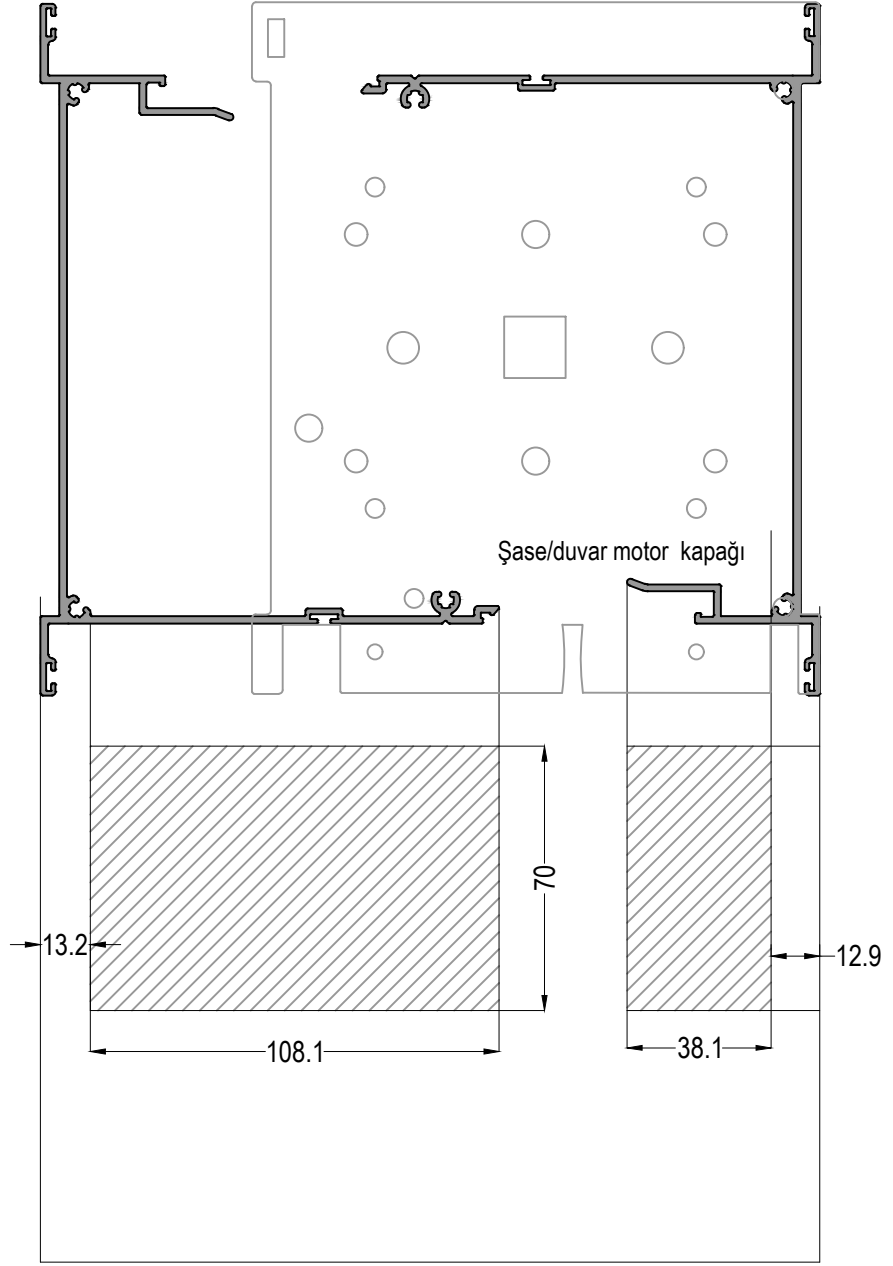

DIN 934 M5



DIN 7991 M5X16

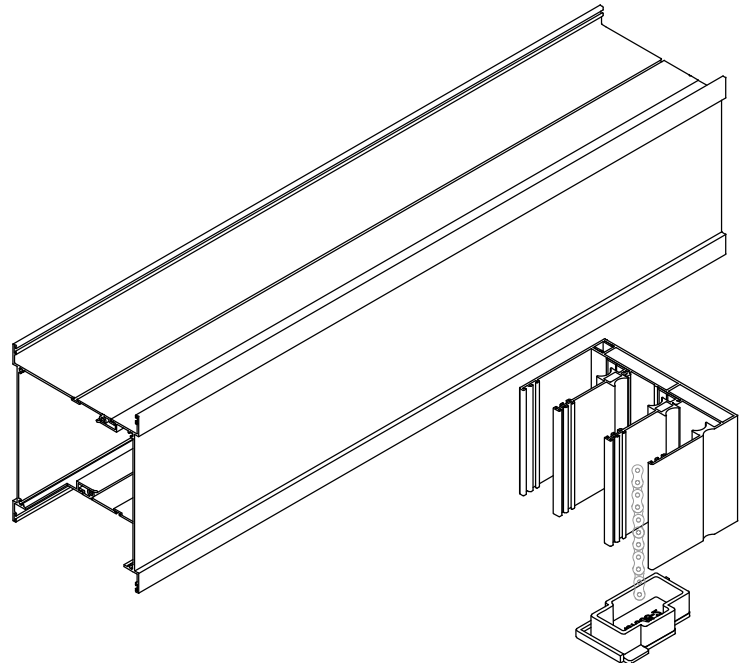

# G130T

ISICAMLI GIYOTİN SÜRME CAM BALKON SİSTEMİ  
VERTICAL SLIDING GLASS BALCONY SYSTEM WITH THERMAL GLASS



EM-G130-TK

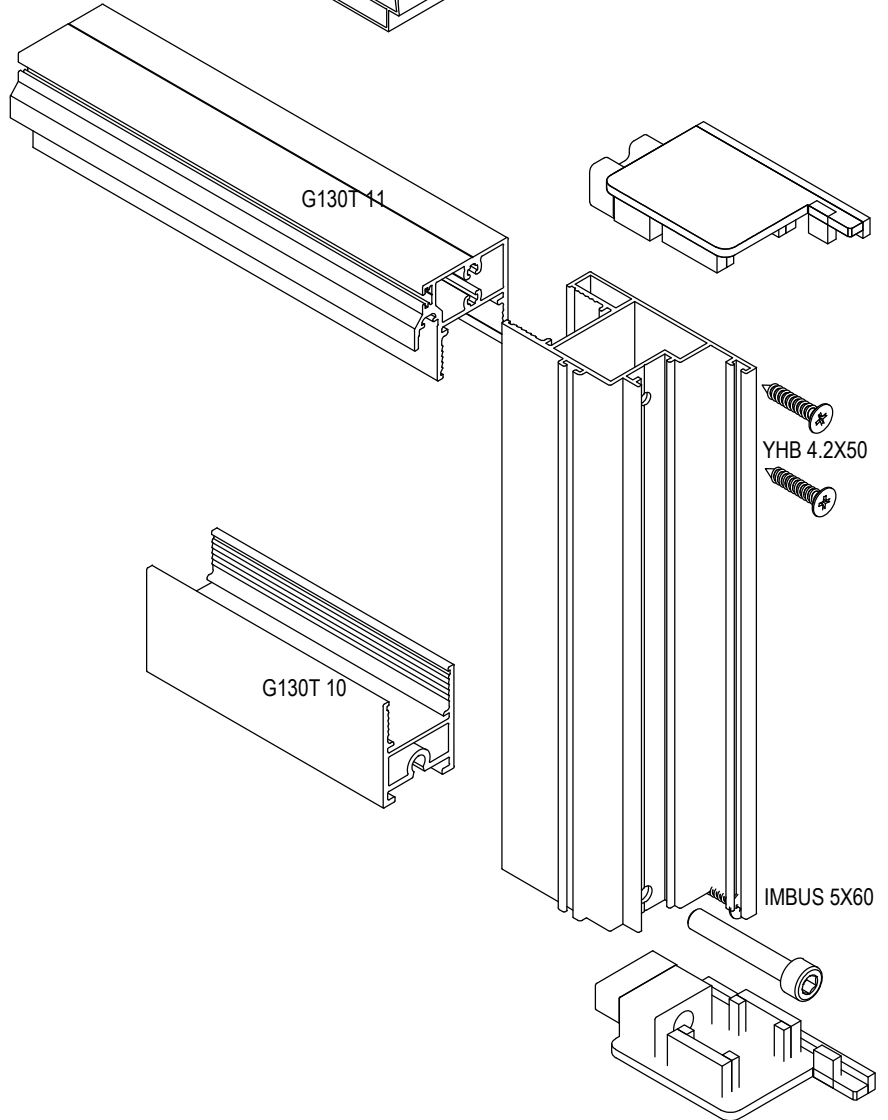
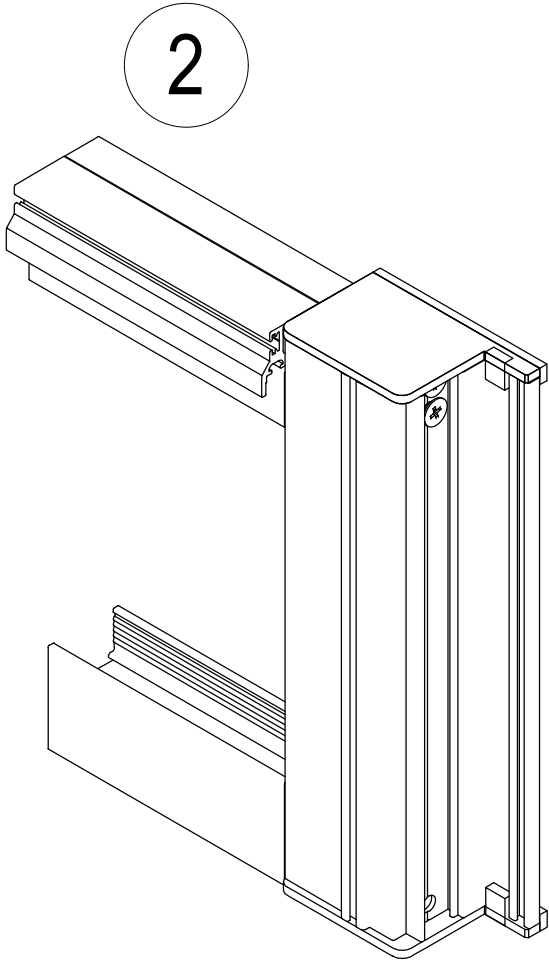
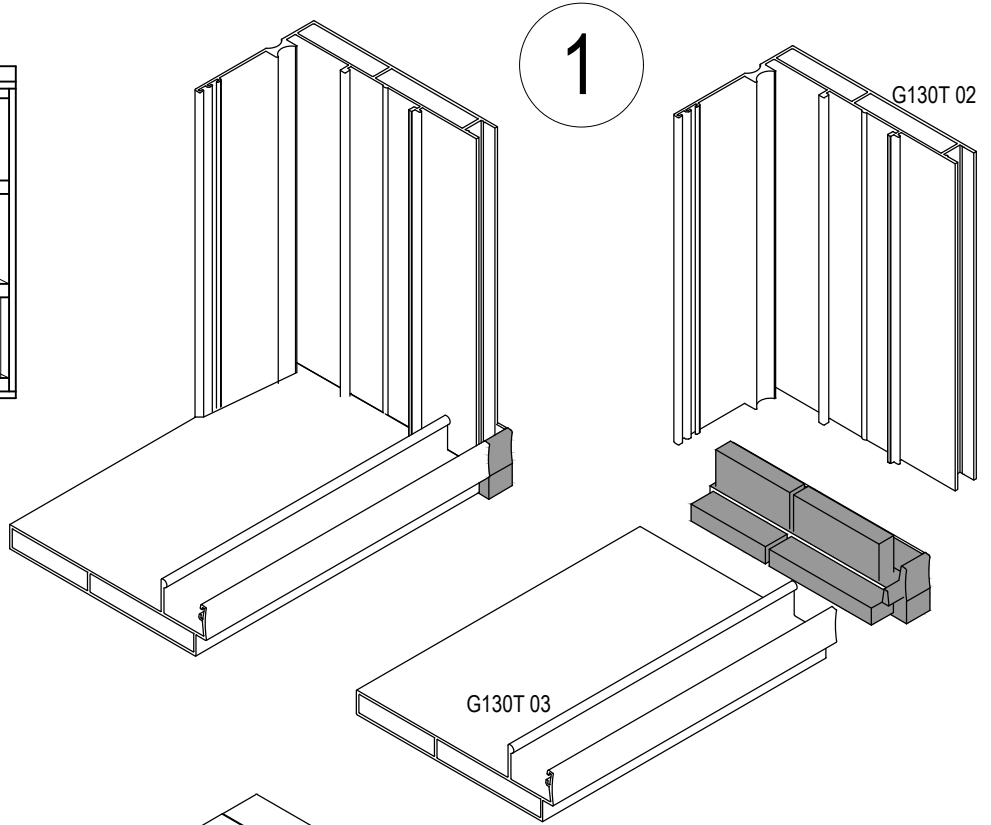
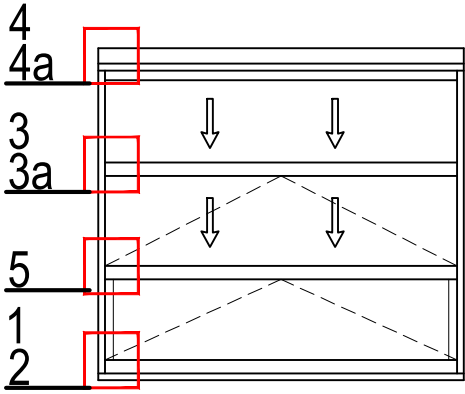

# G130T

ISICAMLI GIYOTIN SÜRME CAM BALKON SİSTEMİ

VERTICAL SLIDING GLASS BALCONY SYSTEM WITH THERMAL GLASS

ASISTAL

3

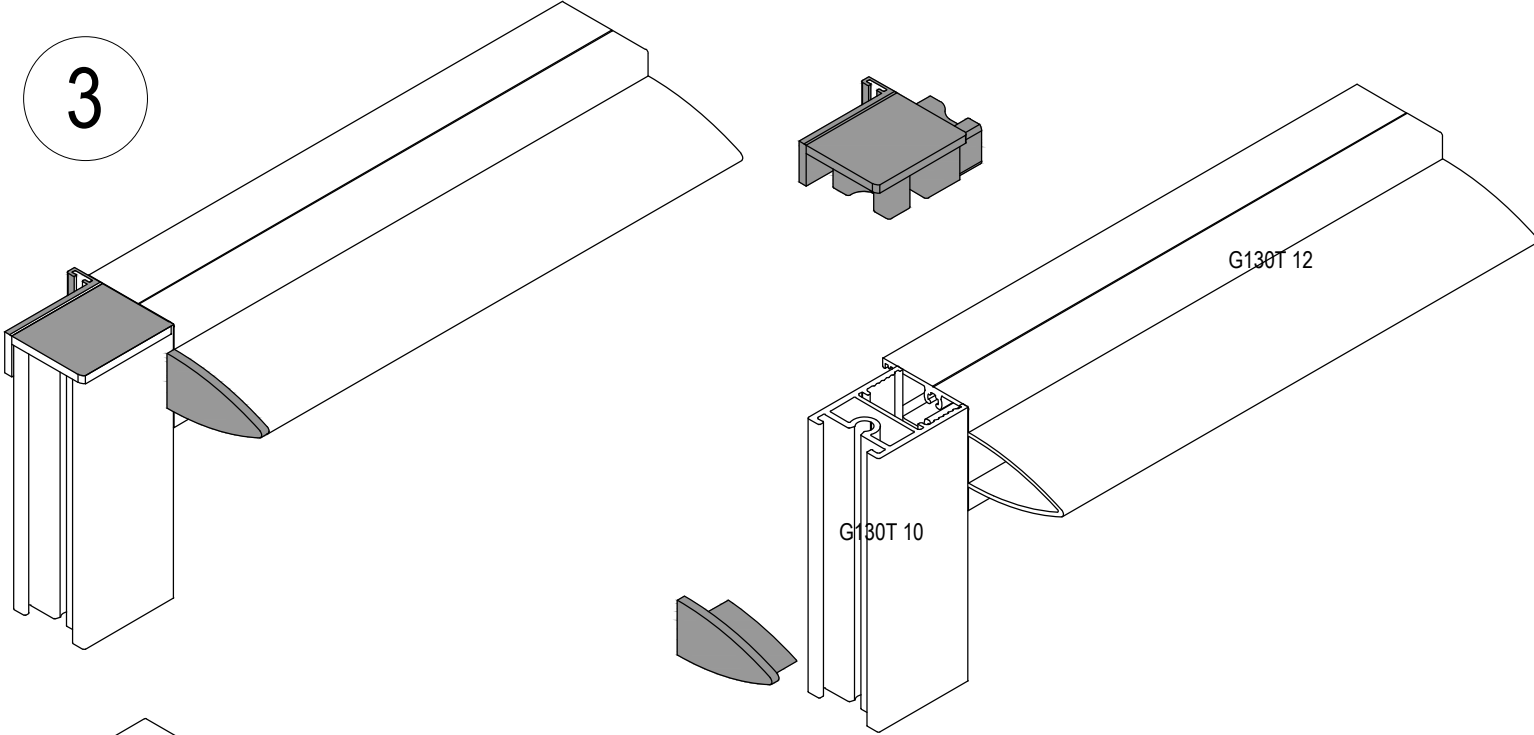

3a

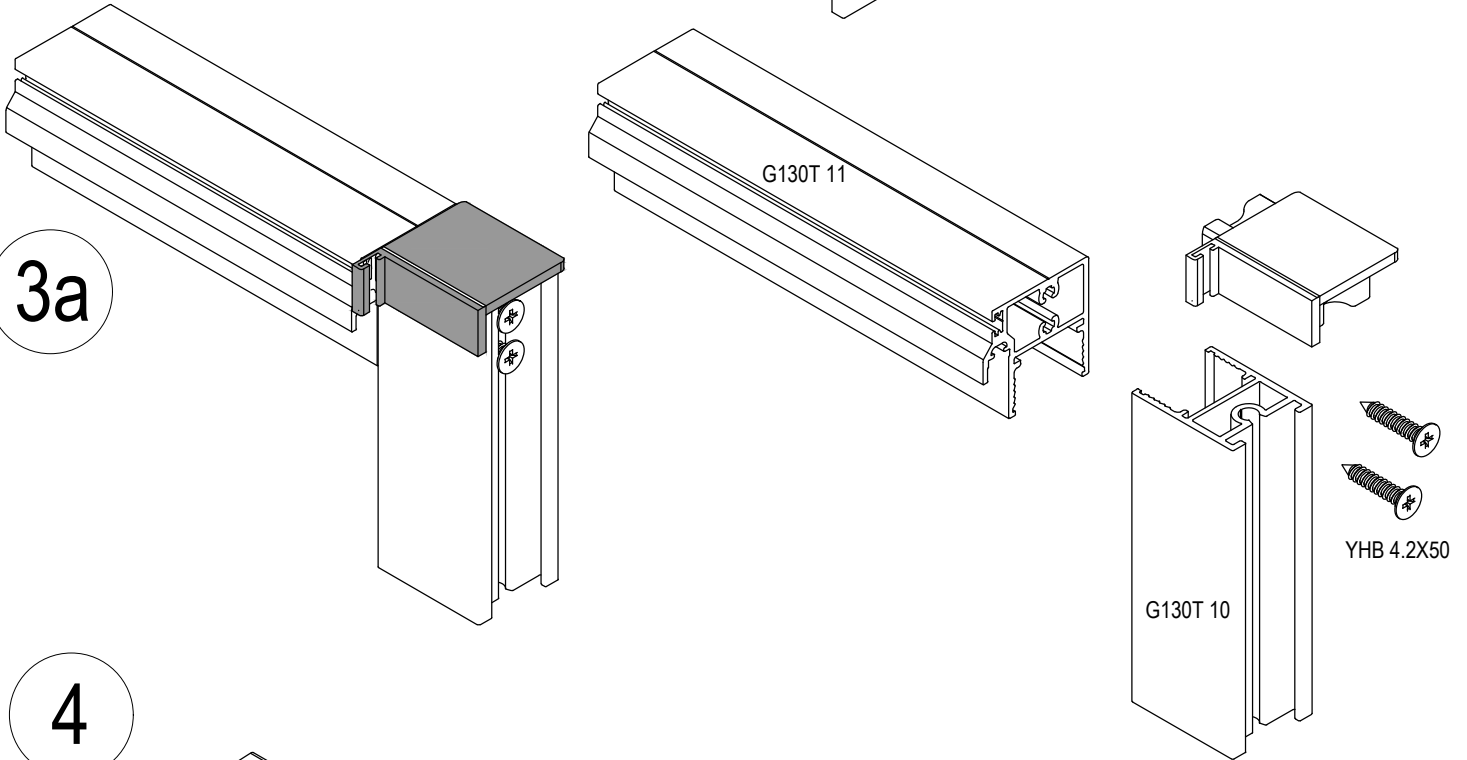

4

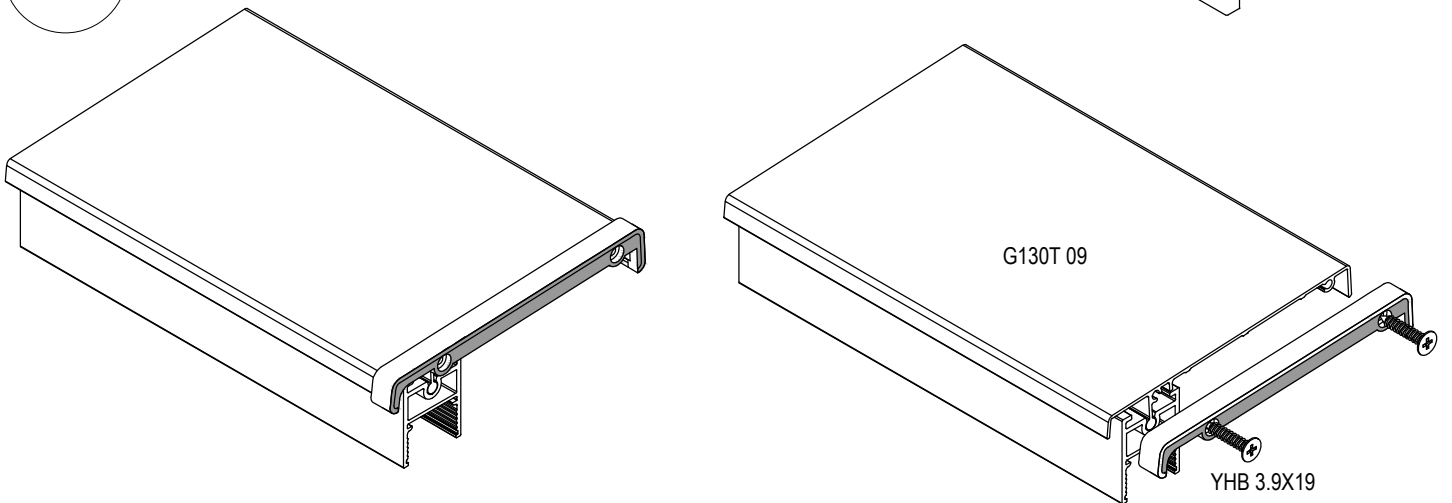

# G130T

ISICAMLI GIYOTİN SÜRME CAM BALKON SİSTEMİ

VERTICAL SLIDING GLASS BALCONY SYSTEM WITH THERMAL GLASS



4a

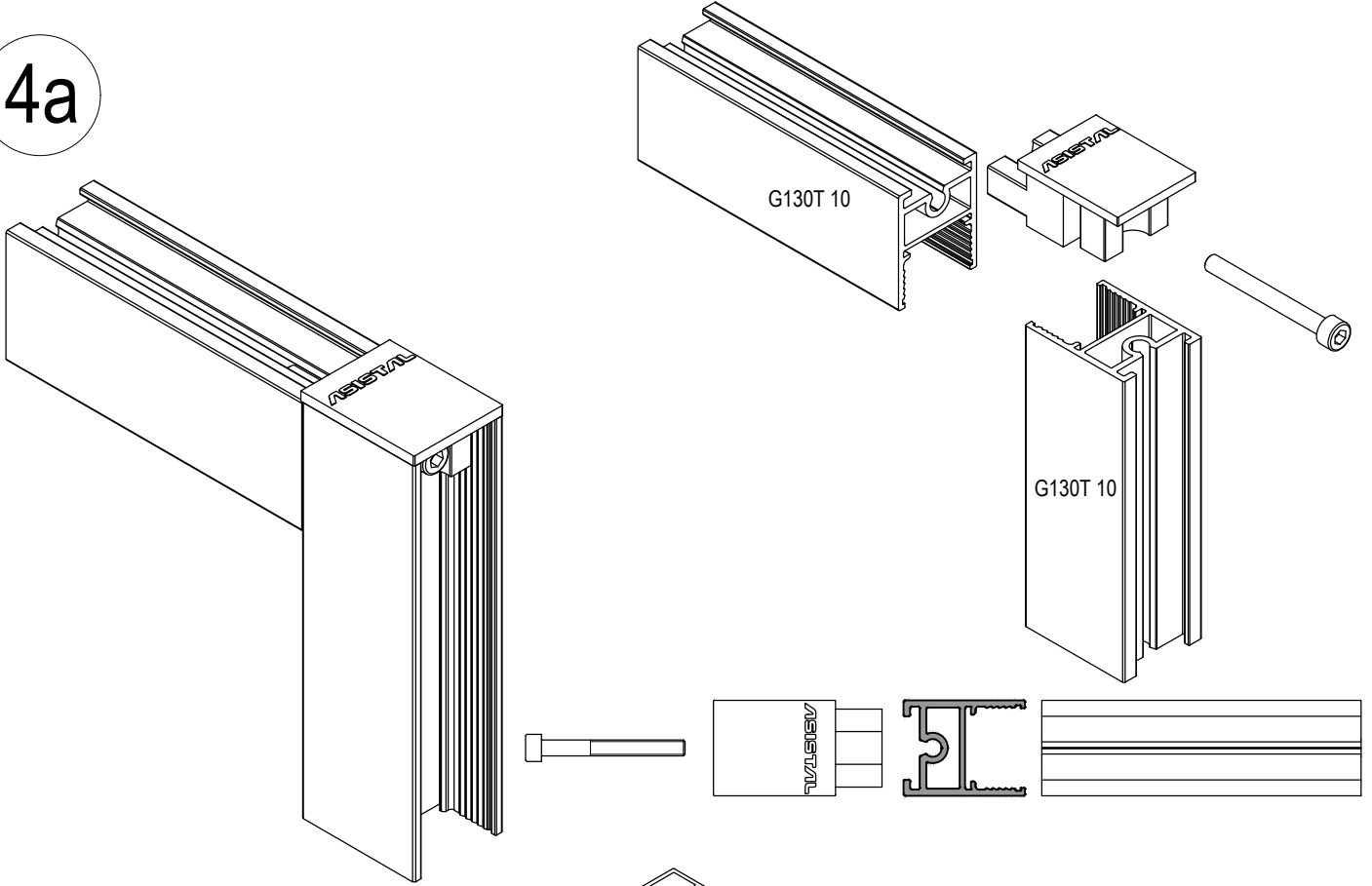

5

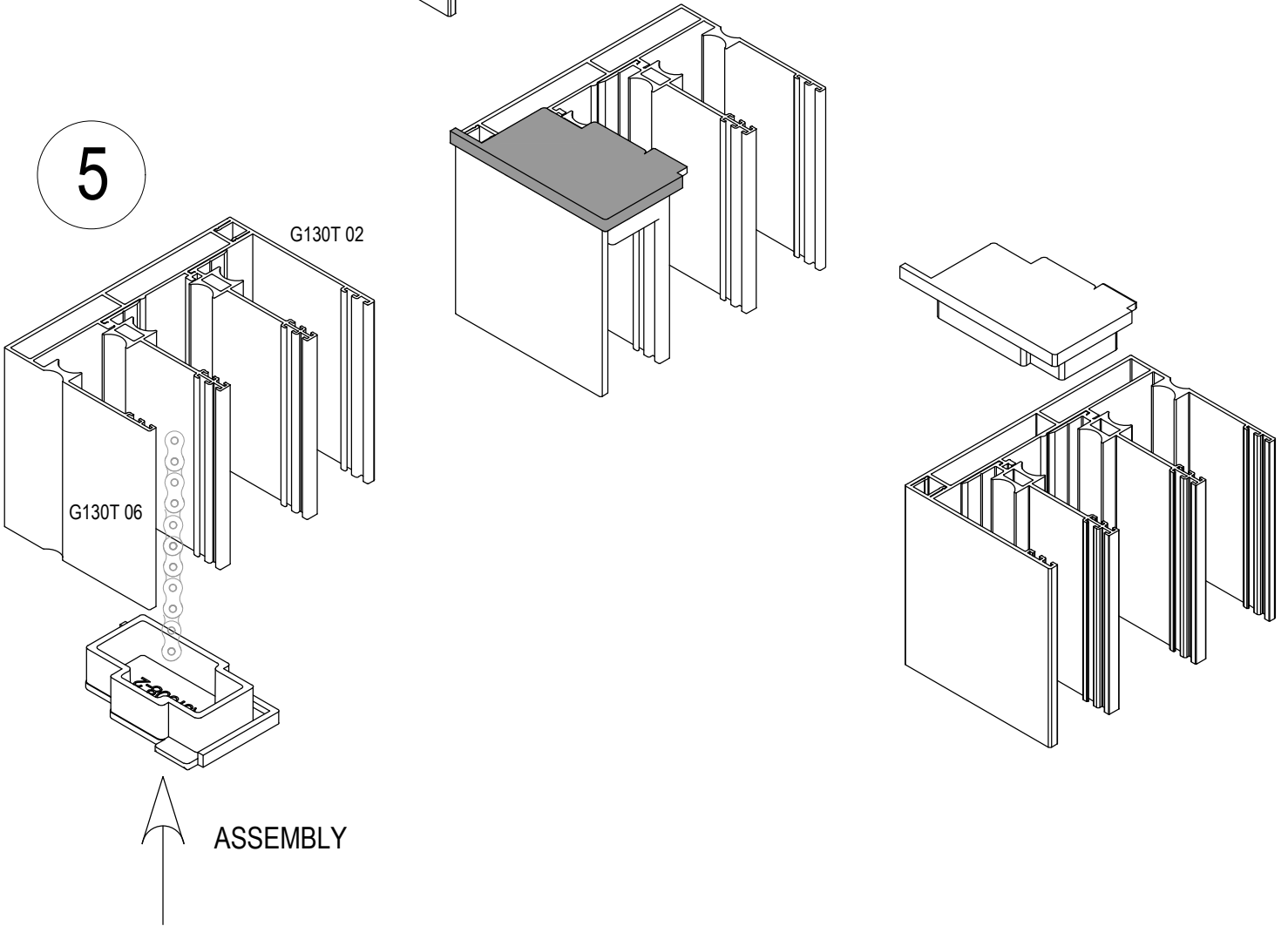

# G130T

ISICAMLI GIYOTIN SÜRME CAM BALKON SİSTEMİ  
VERTICAL SLIDING GLASS BALCONY SYSTEM WITH THERMAL GLASS

**ASISTAL**

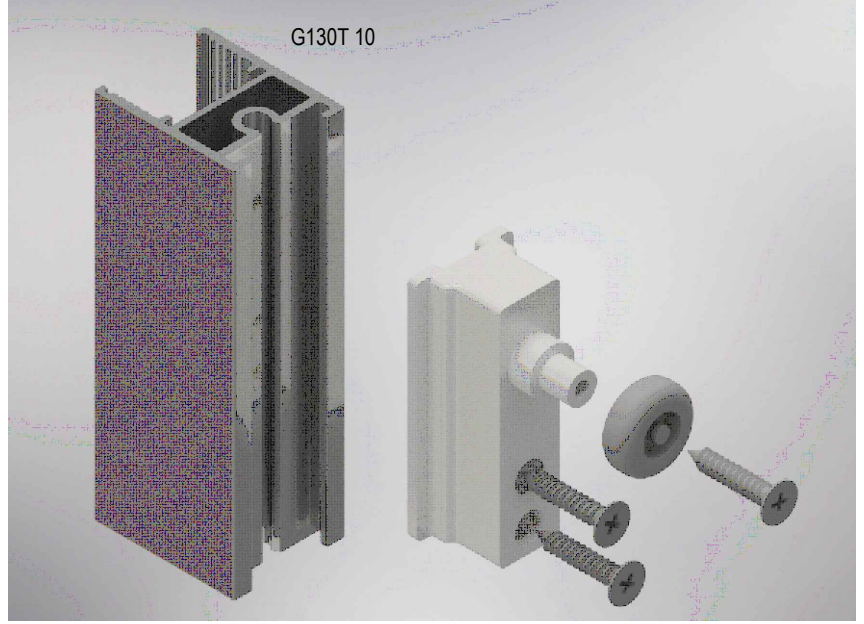
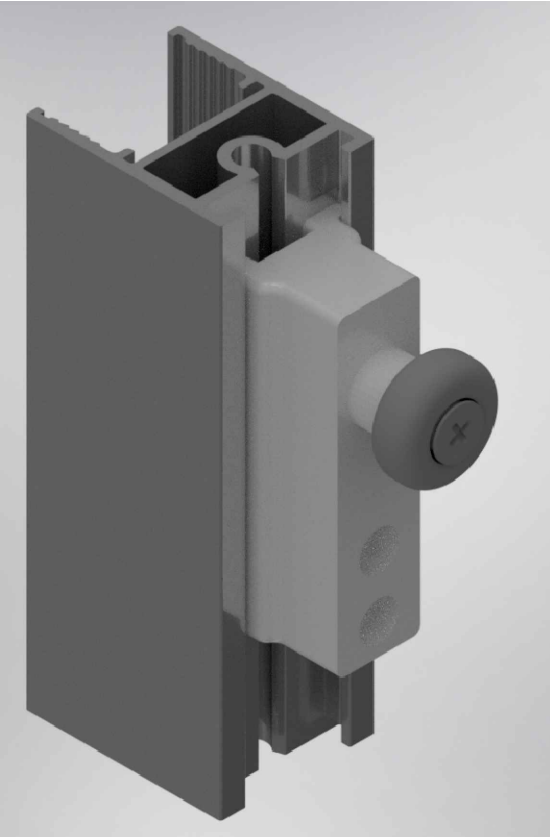

## G130-STR

8 ADET KILAVUZ TEKER + 2 ADET KANAT KAPAK

*8 Pcs SASH SUPPORT ROLLER + 2 Pcs CAP*

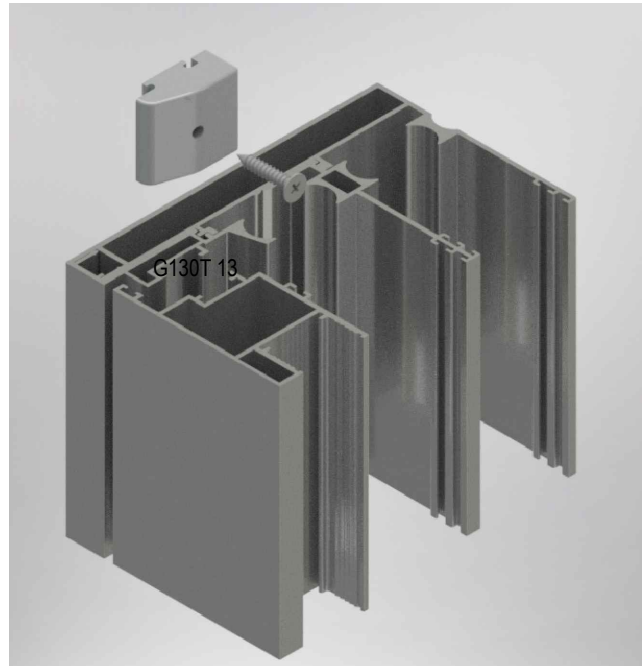
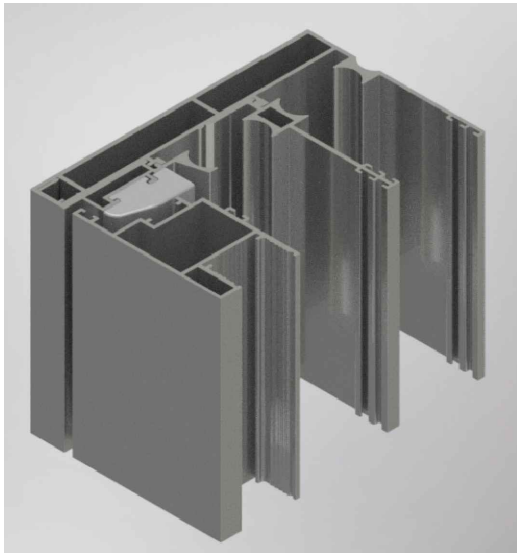



KESİM ÖLÇÜSÜ VE AKSESUAR LİSTESİ  
CUTTING SIZES AND ACCESSORIES

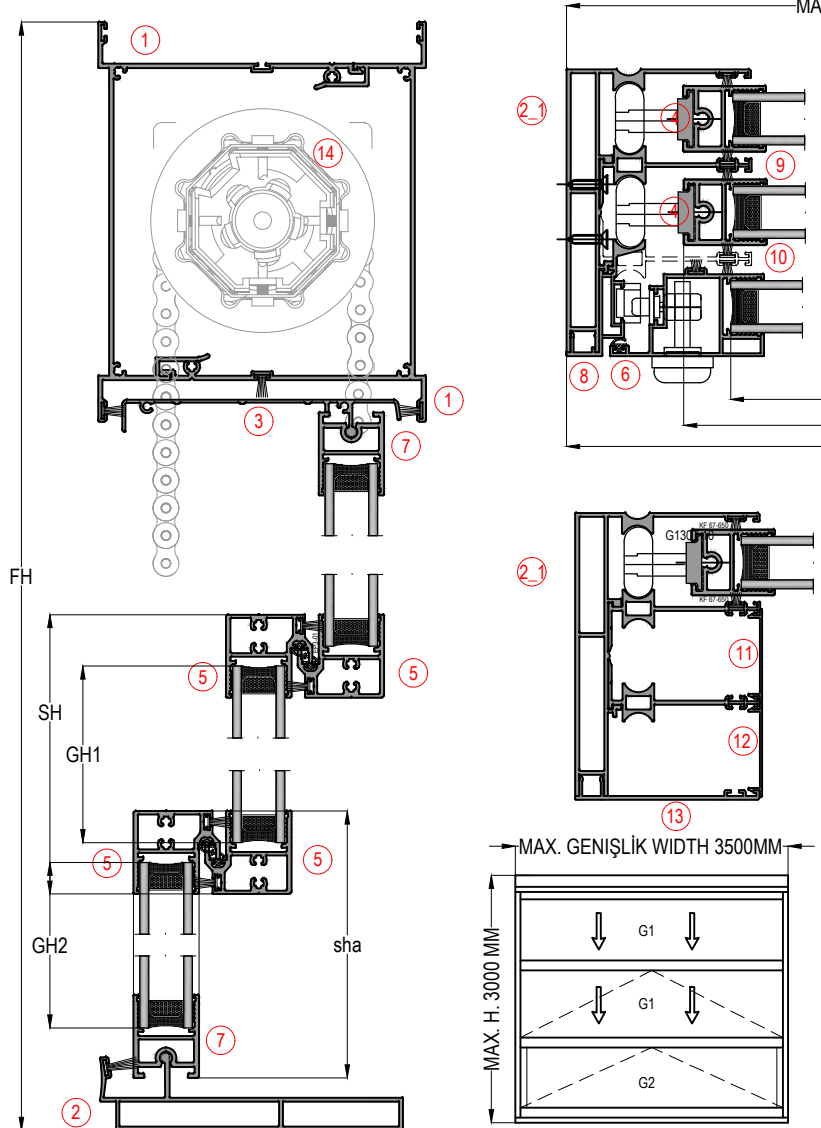

CAM KESİM ÖLÇÜLERİ / GLASS CUTTING SIZES		
KOD / Code	TANIMI / Description	KESİM ÖLÇÜSÜ / Cutting Dimensions
GW	CAM GENİŞLİK / Sash Glass Width	FW-154MM
GH1X2	CAM YÜKSEKLİK / Sash Glass Height	GH1=(FH/3)-87,8mm
GH2	CAM YÜKSEKLİK / Sash Glass Height	GH1=(FH/3)-95,8mm

Civata ve Somunlar / Bolt and Nut		
MİKTAR / Unit	KOD / Code	PROFİL ÇİZİMİ / Drawing
2	M8 PERCİN/Rivet	
2	DIN 7985 M8X25	
2	DIN 912 M5X50	
4	DIN 934 M5	
4	DIN 7991 M5X16	
2	DIN 934 M8	
2	DIN 7991 M8X16	

PROFİLLER / PROFILES					
NO / Number	ADET / Unit	KOD / Code	PROFİL ÇİZİMİ / Drawing	PROFİL TANIMI / Description	KESİM ÖLÇÜSÜ / Cutting Dimensions
1	2	G130T 01		ÜST KASA MOTOR İÇ KAPAK PROFİLİ / Horizontal Top Frame Cover Motor Profile	FW - 12mm
2	1	G130T 03		ALT KASA PROFİLİ / Bottom Frame Profile	FW - 30mm
2,1	2	G130T 02		YAN KASA RAY PROFİLİ / Vertical Frame Rail Profile	FH - 179mm
3	1	G130T 09		TRABZAN KAPAK PROFİLİ / Cover Profile	FW - 200mm
4	4	G130T 10		DÜŞEY KANAT PROFİLİ / Vertical Sash Profile	SH=((FH-118)/3)-3MM
5	2	G130T 10		ALT ÜST KANAT PROFİLİ / Top,Bottom Sash Profile	FW-182mm
6	2	G130T 13		İSPANYOLET KANAT PROFİLİ / Lock Sash Profile Bottom	SH1=((FH-118)/3)-11MM
7	4	G130T 11		YATAY KANAT PROFİLİ / Horizontal Sash Profile	FW-182mm
8	2	G130T 05		ADAPTOR PROFİLİ / Adapter Profile	SHA=((FH-118)/3)+10MM
9	2	G130T 04		RAY PROFİLİ S1/ Rail Profile	FH - 179mm
10	2	G130T 04		RAY PROFİLİ S2/ Rail Profile	(FH-179)-SHA-3
11	2	G130T 07		YAN ÇİTA PROFİLİ / Side Cover Profile	SH-27MM
12	2	G130T 07		YAN ÇİTA PROFİLİ / Side Cover Profile	(FH-179)-SHA-3
13	2	G130T 06		DİKME ÖN KAPAK PROFİLİ / Cover Profile	(FH-179)-SHA-3
14	1	G100 A12		MOTOR BORU PROFİLİ / Horizontal Motor Profile	FW - 50mm

AKSESUARLAR / ACCESSORIES				AKSESUARLAR / ACCESSORIES			
MİKTAR / Unit	KOD / Code	PROFİL ÇİZİMİ / Drawing	PROFİL TANIMI / Description	MİKTAR / Unit	KOD / Code	PROFİL ÇİZİMİ / Drawing	PROFİL TANIMI / Description
1 Adet / Pcs	G100-A1		120 LİK MOTOR / Motor	2 Adet / Pcs	G130-A05		ZİNCİR ASKI SACI / Hanging Part
* 1 Adet / Pcs	G100 - A2		TEK Lİ KUMANDA / Single Remote Control	2 Adet / Pcs	ASI-V 0501		MAKAS / Arm.
* 1 Adet / Pcs	G100 - A3		ÇOKLU KUMANDA / Multi Remote Control	1 Adet / Pcs	EM125-23-1		RULMAN YATAĞI / Roller Chanel
2 Adet / Pcs	G100T - A4		DİŞLİ / Gear	2 Adet / Pcs	G130-STR		Kanat Destek Takozu
1 Adet / Set	G100T - A6		METAL ASKI ZİNCİRİ+2 Adaptor / Metal Chain				
1 Takım / Set	G130T - A1		MOTOR YAN SACI / Motor Side Cover	FW	KF67-1500		KİL FİTİL / Brush
1 Adet / Pcs	G100 - A11-3		GIYOTIN TAMBUR BAŞI / Motor Provisions	7XFW	KF67-1000		KİL FİTİL / Brush
1 Takım / Set	EM-G130-TK		KAPAK TAKIMI / Cover Set	6XFH-(4xFH/3)	KF67-650		KİL FİTİL / Brush
2 Adet / Pcs	G130-A01		ZİNCİR KILAVUZ YÜZÜĞÜ / Chain Guide	(4XFW)+(FH/3x2)	MO 60		Bini Fıtlı / Gasket
1 Takım / Set	G130-STR		KILAVUZ TEKER+KAPAK / Roller Guide+Cap				M8 Perçin / Rivet
2 Adet / Pcs	ASI-WH 008		İSPANYOLET KOL / Handle				
2 Adet / Pcs	ASI-MP-ES 400		İSPANYOLET / Espagnolette				
4 Adet / Pcs	ASI-MP-SP 01		PİM KARŞILIĞI / Rod Profile STR.				