

**G100**

**GİYOTİN SÜRME CAM BALKON SİSTEMİ**  
VERTICAL SLIDING GLASS BALCONY SYSTEM

**ASISTAL**

**KESİM ve MONTAJ**  
*CUTTING & ASSEMBLY*

# G100

GIYOTIN SÜRME CAM BALKON SİSTEMİ  
VERTICAL SLIDING GLASS BALCONY SYSTEM

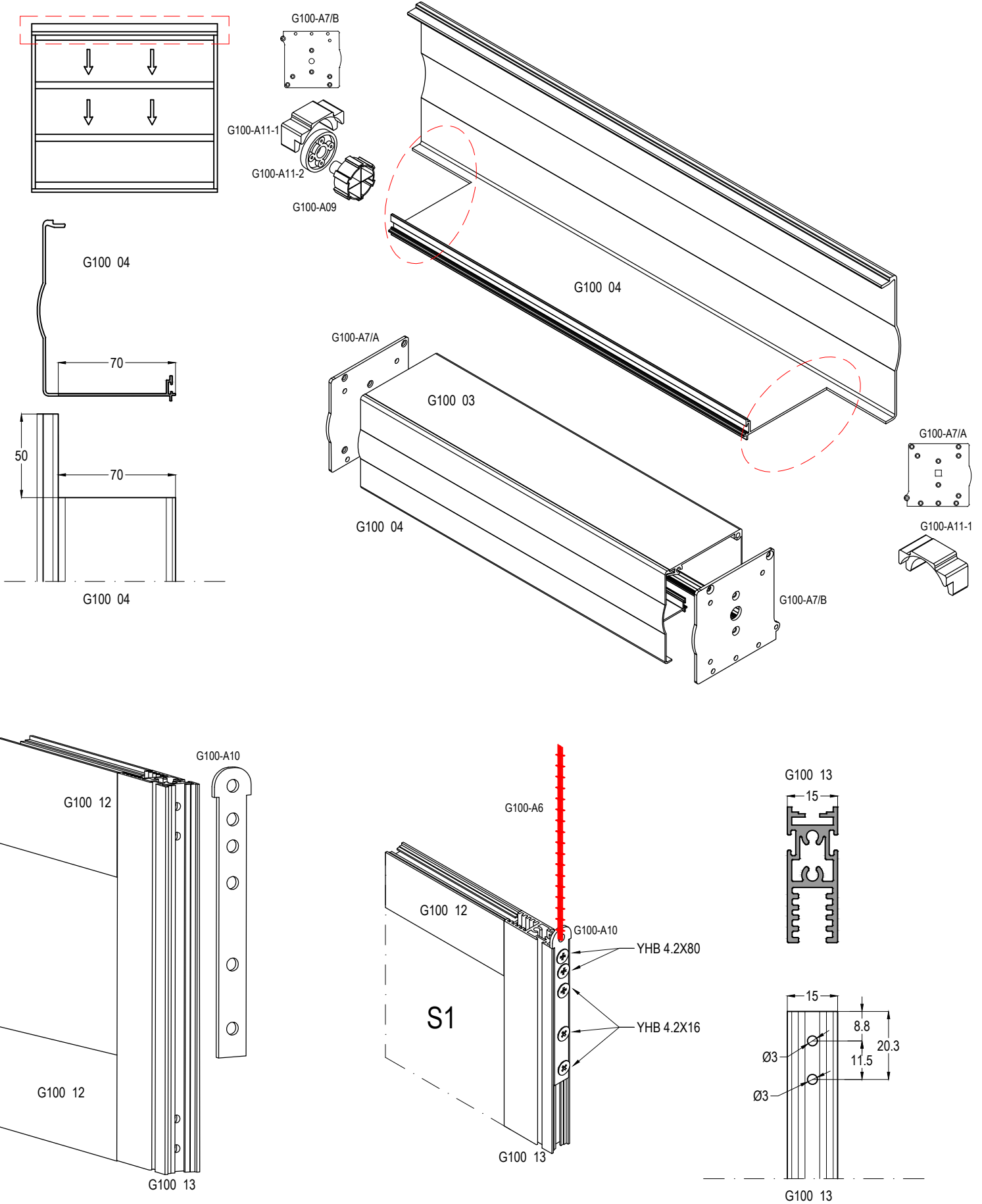

**G100**

**GİYOTİN SÜRME CAM BALKON SİSTEMİ**  
VERTICAL SLIDING GLASS BALCONY SYSTEM

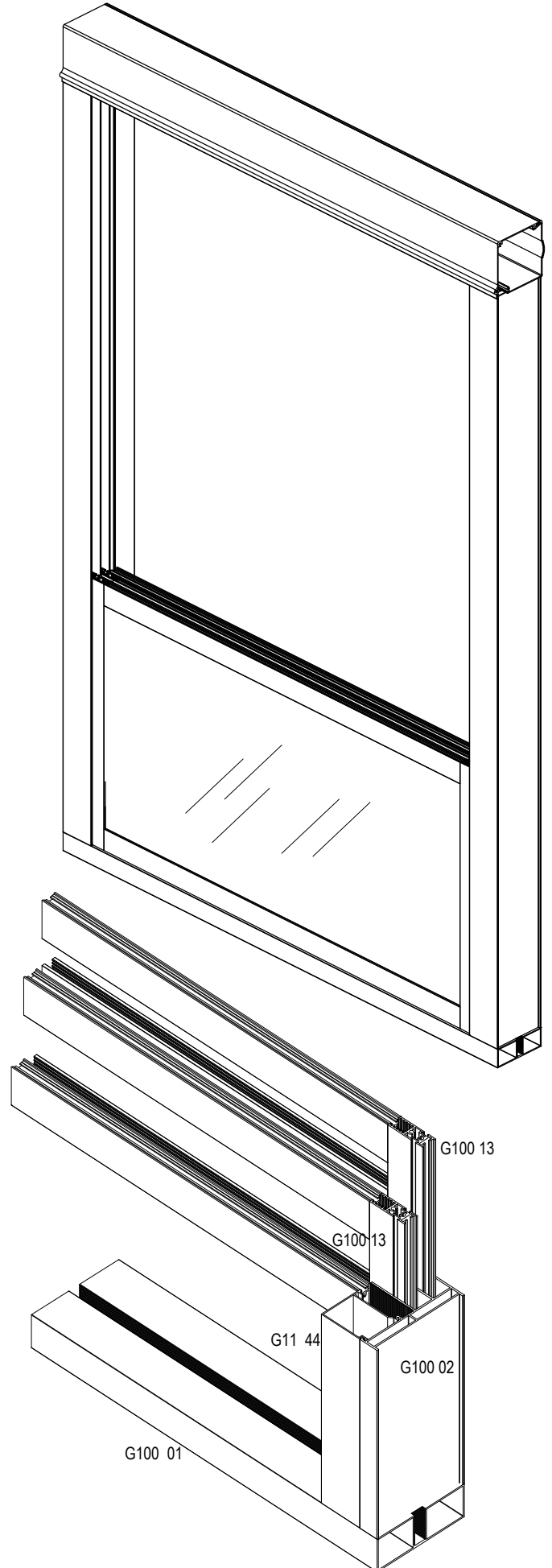
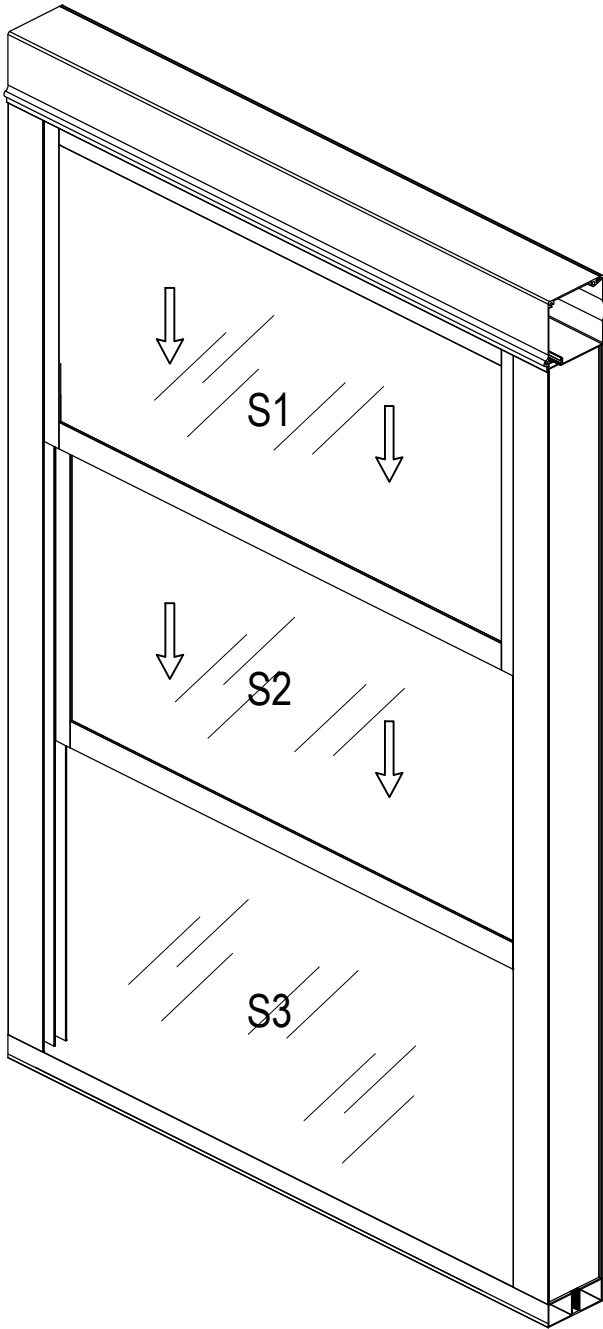

# G100

GIYOTIN SÜRME CAM BALKON SİSTEMİ  
VERTICAL SLIDING GLASS BALCONY SYSTEM

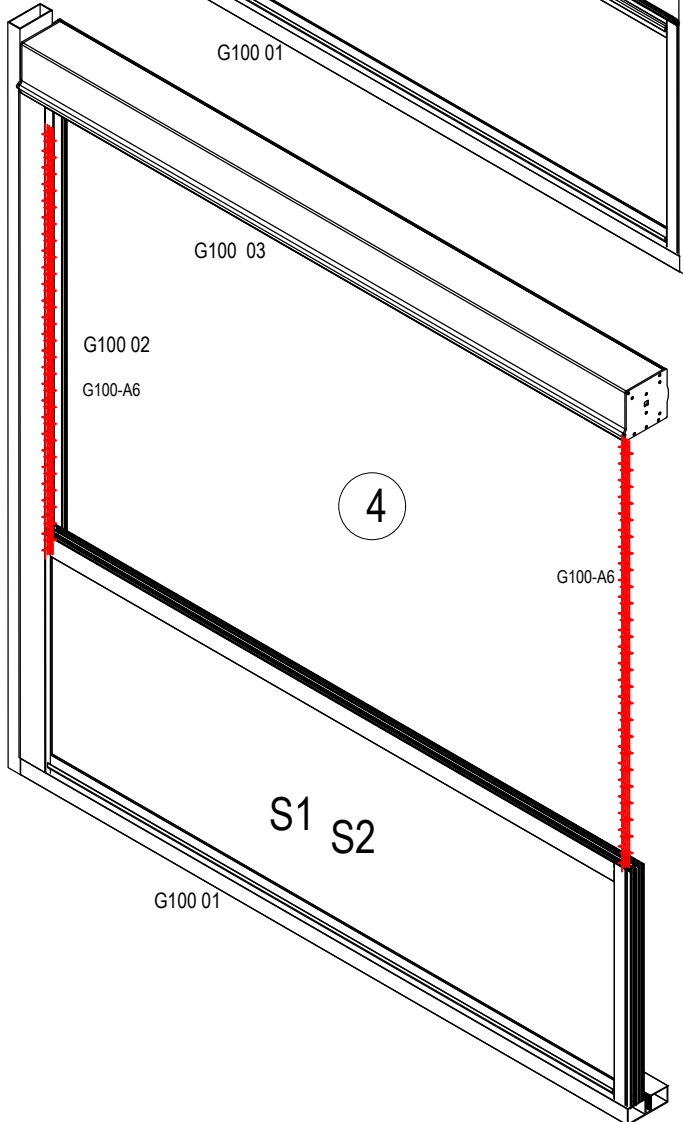
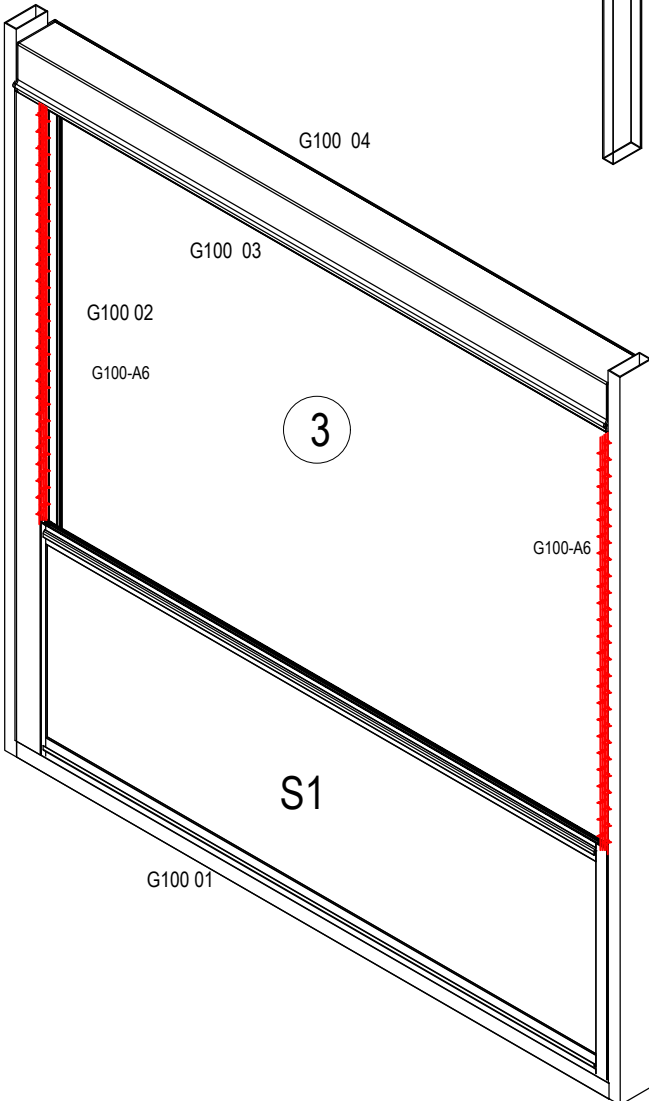
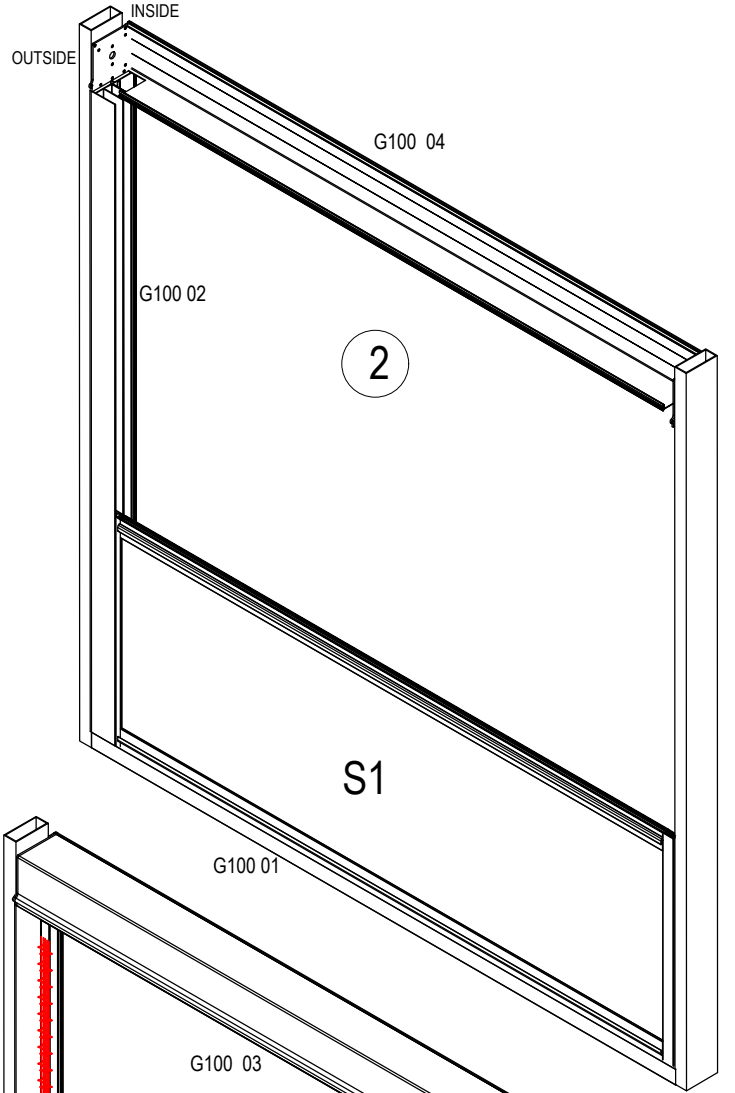
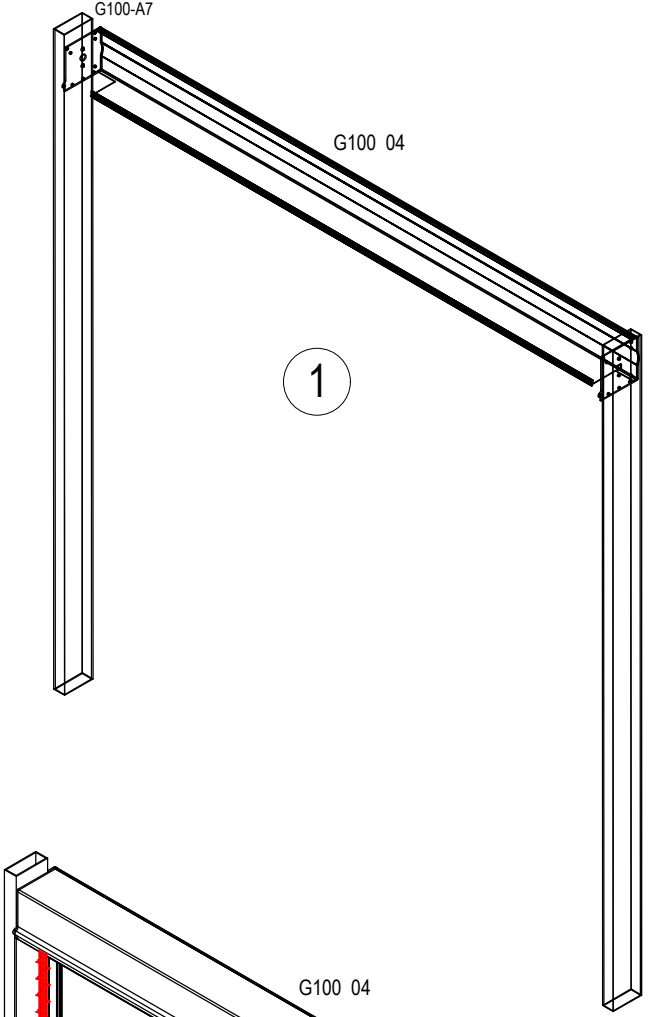

# G100

GİYOTİN SÜRME CAM BALKON SİSTEMİ  
VERTICAL SLIDING GLASS BALCONY SYSTEM

## ASISTAL

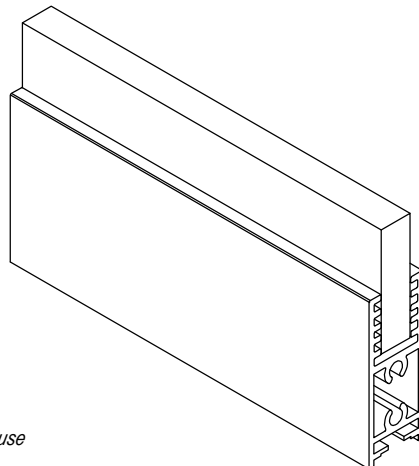
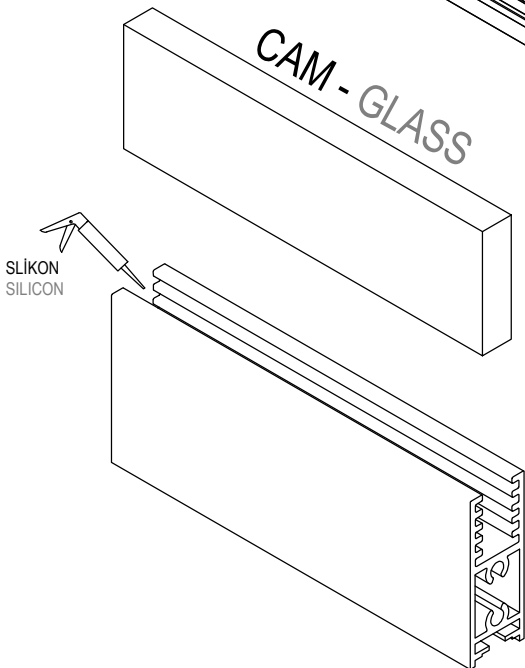
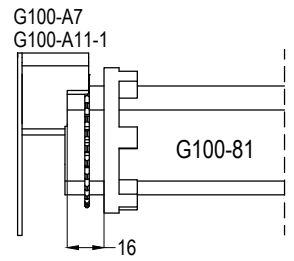
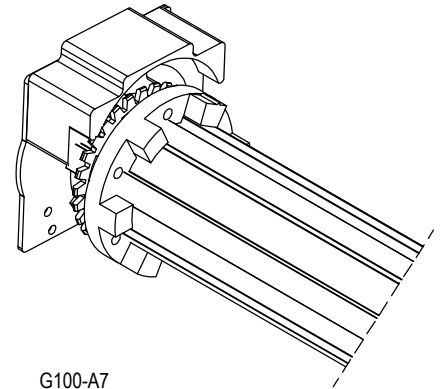
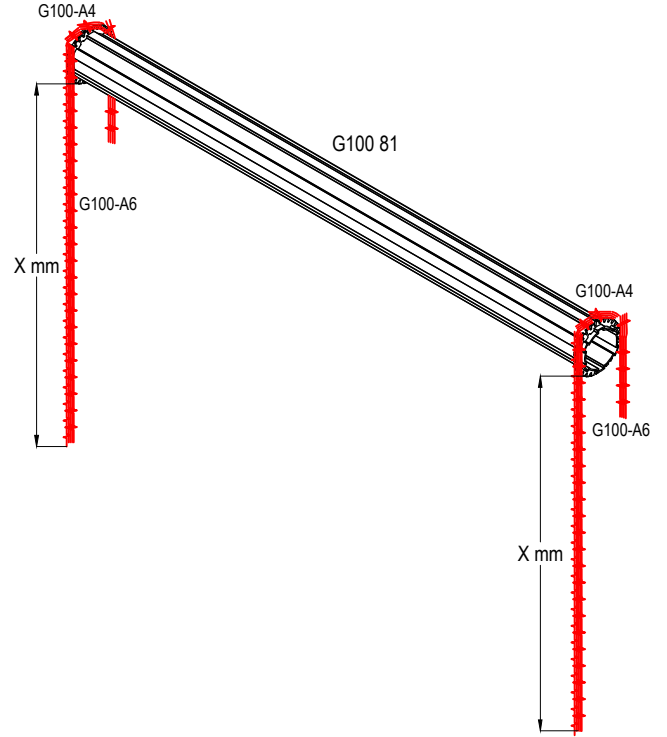
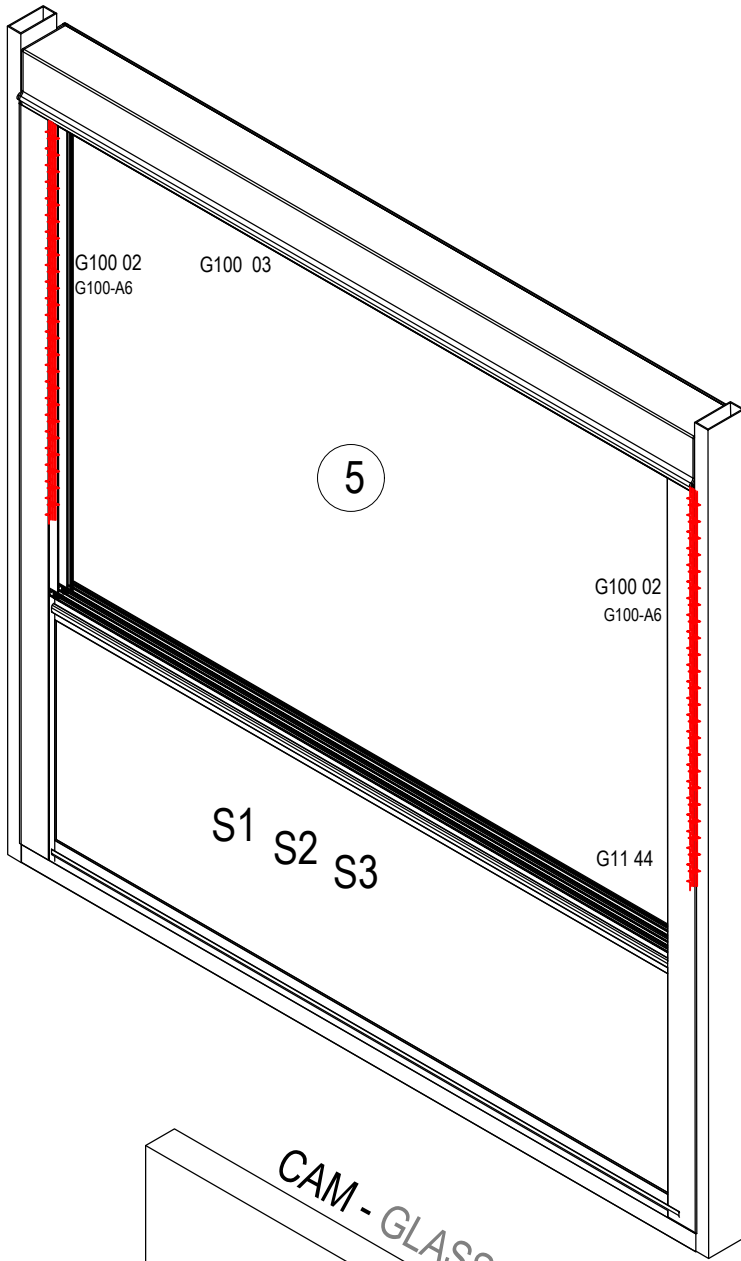

S1-S2-S3 NOLU KANATLAR CAMLA BİRLİKTE GÖSTERİLDİĞİ GİBİ TOPLANMALI  
CAM YUVASINA ÖNCESİNDE SİLİKON SIKILMALI  
S1-S2-S3 number sashes must be assembly with glass like show. Before the glass placement must be use  
silicone

# G100

GIYOTİN SÜRME CAM BALKON SİSTEMİ  
VERTICAL SLIDING GLASS BALCONY SYSTEM

ASISTAL

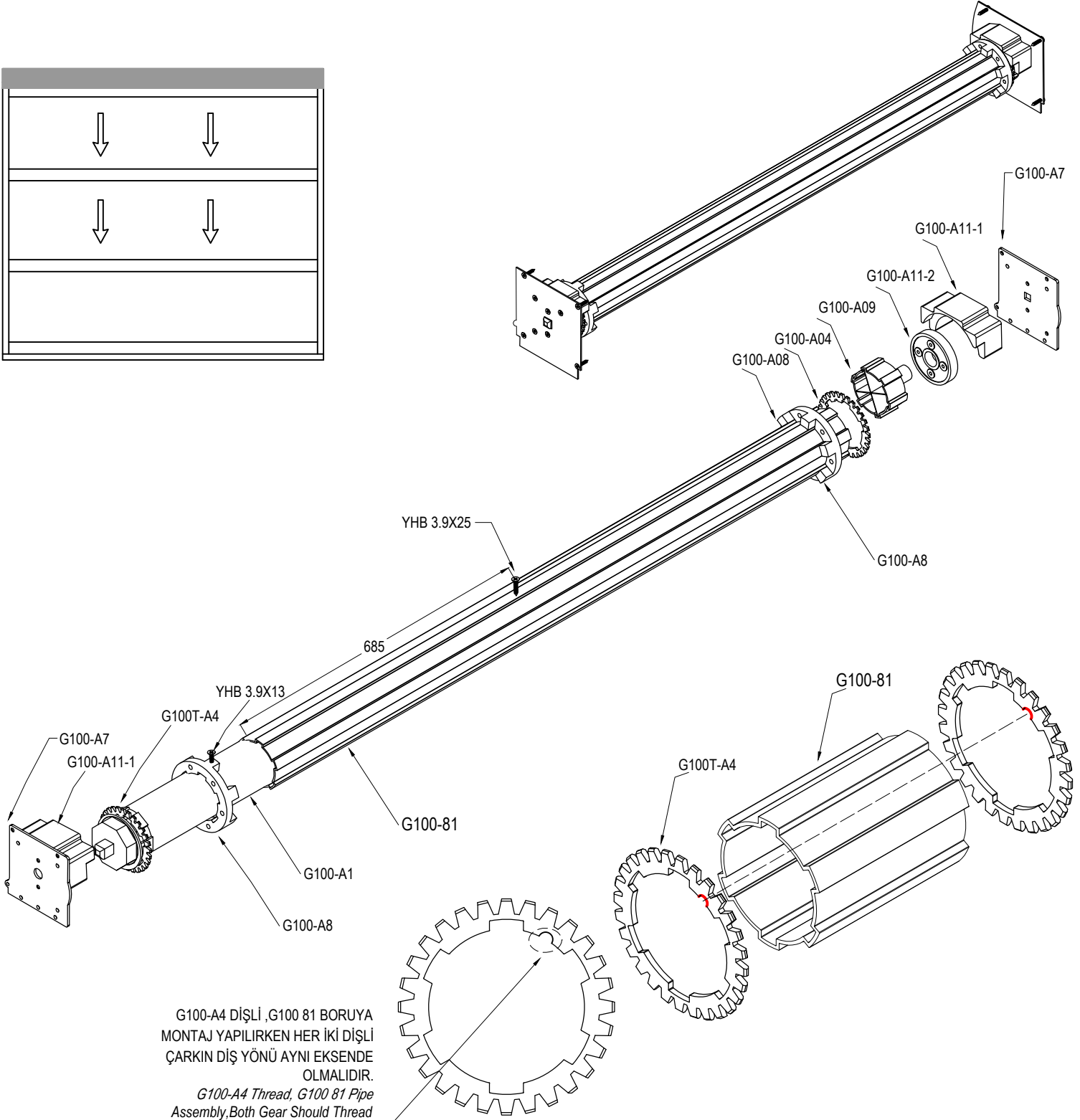
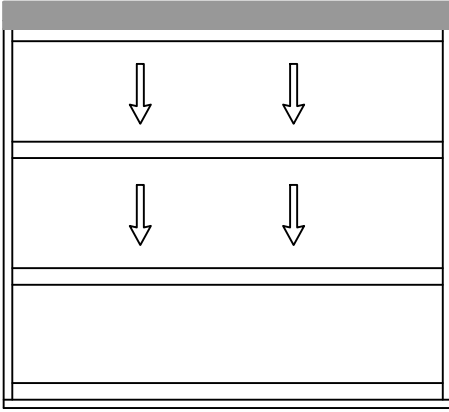

G100-A4 DİŞLİ ,G100 81 BORUYA  
MONTAJ YAPILIRKEN HER İKİ DİŞLİ  
ÇARKIN DİŞ YÖNÜ AYNI EKSENDE  
OLMALIDIR.

*G100-A4 Thread, G100 81 Pipe  
Assembly,Both Gear Should Thread  
Face Should Be The Same Axis.*

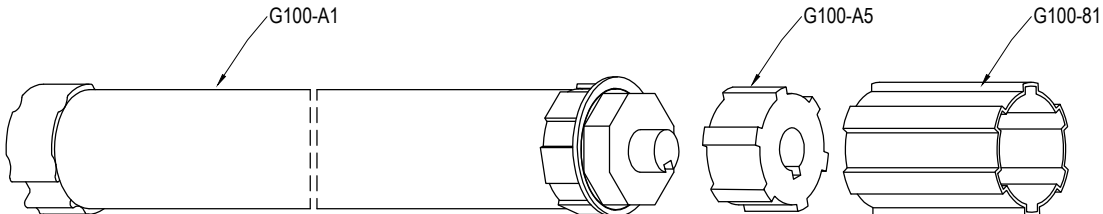

# G100

GIYOTİN SÜRME CAM BALKON SİSTEMİ  
VERTICAL SLIDING GLASS BALCONY SYSTEM

# ASISTAL

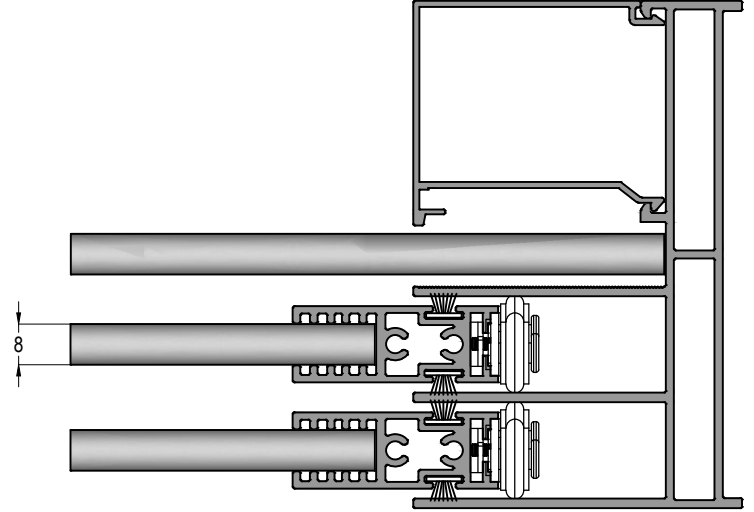
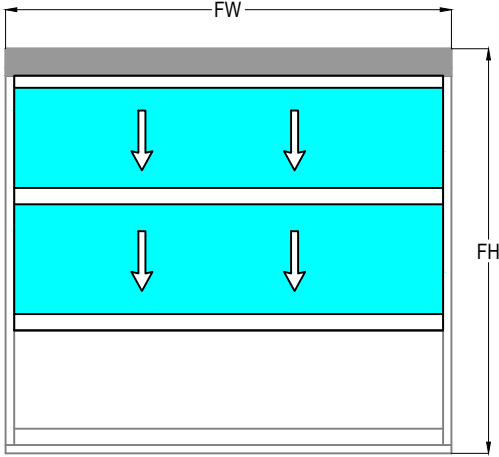

**NOT: MAX KANAT ENİ 3250mm, MAX KANAT YÜKSEKLİĞİ 2800mm**  
MAX SASH WITDTH 3250mm, MAX SASH HEIGHT 2800mm

## G100 2 KANAT AĞIRLIKLARI (8mm Cam) - 2 SASH WEIGHTS (8mm Glass)

### GENİŞLİK (MM) FW - WIDTH

YÜKSEKLİK (MM) FW - HEIGHT	KG.	1000	1250	1500	1750	2000	2250	2500	2750	3000	3250
	1400	17,12	27,87	33,20	38,54	43,88	49,22	54,56	59,90	65,24	70,58
1500	23,94	29,62	35,29	40,96	46,63	52,31	57,98	63,65	69,33	75,00	
1600	25,36	31,37	37,37	43,38	49,38	55,39	61,40	67,40	73,41	79,42	
1700	26,78	33,12	39,45	45,79	52,13	58,47	64,81	71,15	77,49	83,83	
1800	28,19	34,87	41,54	48,21	54,88	61,56	68,23	74,90	81,58	88,25	
1900	29,61	36,62	43,62	50,63	57,63	64,64	71,65	78,65	85,66	92,67	
2000	31,03	38,37	45,70	53,04	60,38	67,72	75,06	82,40	89,74	97,08	
2100	32,4	40,12	47,79	55,46	63,13	70,81	78,48	86,15	93,83	101,50	
2200	33,86	41,87	49,87	57,88	65,88	73,89	81,90	89,90	97,91	105,92	
2300	35,28	43,62	51,95	60,29	68,63	76,97	85,31	93,65	101,99	110,33	
2400	36,69	45,37	54,04	62,71	71,38	80,06	88,73	97,40	106,08	114,75	
2500	38,11	47,12	56,12	65,13	74,13	83,14	92,15	101,15	110,16	119,17	
2600	39,53	48,87	58,20	67,54	76,88	86,22	95,56	104,90	114,24	123,58	
2700	40,94	50,62	60,29	69,96	79,63	89,31	98,98	108,65	118,33	128,00	
2800	42,36	52,37	62,37	72,38	82,38	92,39	102,40	112,40	122,41	132,42	

### KESİM ÖLÇÜSÜ VE AKSESUAR LİSTESİ CUTTING SIZES AND ACCESSORIES

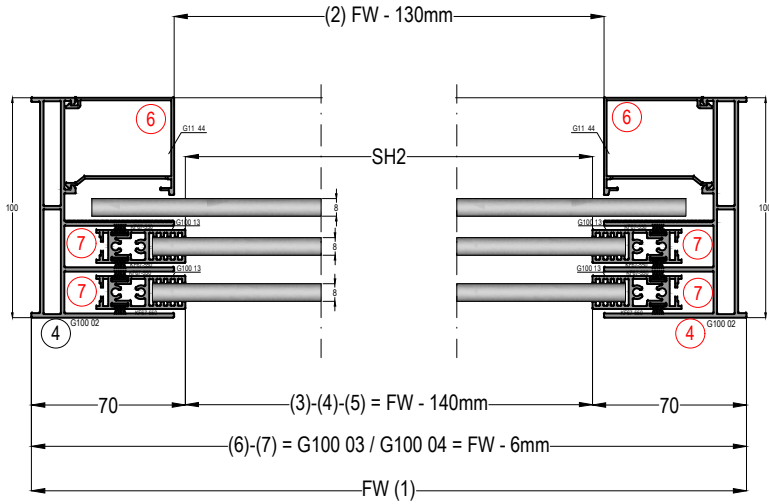

**NOT: MAX KANAT ENİ 3500mm, MAX KANAT YÜKSEKLİĞİ 2800mm**  
MAX SASH WIDTH 3500mm, MAX SASH HEIGHT 2800mm

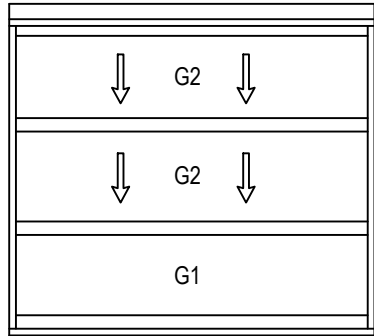

CAM KESİM ÖLÇÜLERİ / GLASS CUTTING SIZES		
KOD / Code	TANIMI / Description	KESİM ÖLÇÜSÜ / Cutting Dimensions
G1	G1 - SABİT CAM GENİŞLİK / Fixed Sash Glass Width	FW - 55mm
G1	G1 - SABİT CAM YÜKSEKLİK / Fixed Sash Glass Height	(FH - 41mm) / 3
G2	G2 - HAREKETLİ CAM GENİŞLİK / Sash Glass Width	FW - 110mm
G2	G2 - HAREKETLİ CAM YÜKSEKLİK / Sash Glass Height	(FH - 200mm) / 3

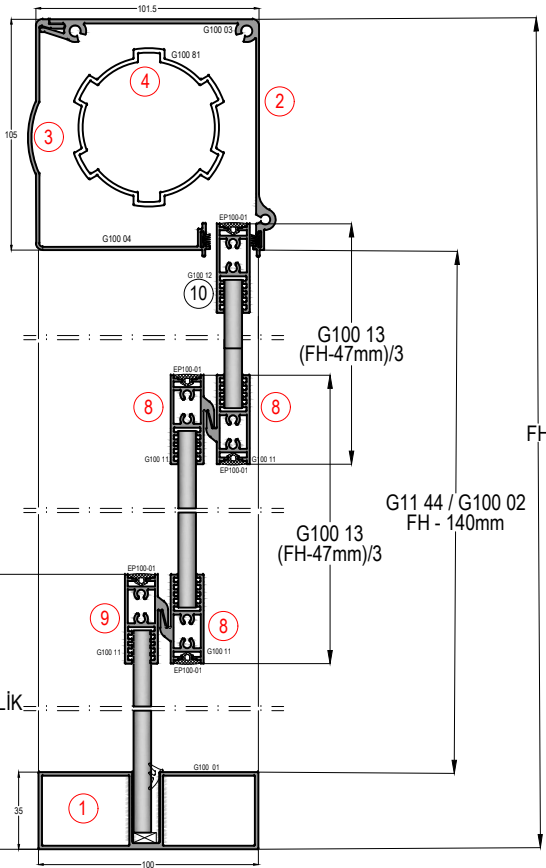

PROFİLLER / PROFILES					
NO / Number	ADET / Unit	KOD / Code	PROFİL ÇİZİMİ / Drawing	PROFİL TANIMI / Description	KESİM ÖLÇÜSÜ / Cutting Dimensions
1	1	G100 01		YATAY ALT KASA PROFİLİ / Horizontal Bottom Frame Profile	FW
2	1	G100 03		ÜST KASA MOTOR İÇ KAPAK PROFİLİ / Horizontal Top Frame Cover Motor Profile	FW - 6mm
3	1	G100 04		ÜST KASA MOTOR DIŞ KAPAK PROFİLİ / Horizontal Top Frame Cover Motor Profile	FW - 6mm
4	1	G100 81		MOTOR BORU PROFİLİ / Horizontal Motor Profile	FW - 40mm
5	2	G100 02		YAN KASA RAY PROFİLİ / Vertical Frame Rail Profile	FH - 140mm
6	2	G11 44		DÜŞEY SABİT CAM ÇITASI / Vertical Glazing Bead	FH - 140mm
7	4	G100 13		DÜŞEY KANAT PROFİLİ / Vertical Sash Profile	(FH - 47mm) / 3
8	3	G100 11		YATAY KANAT PROFİLİ / Horizontal Sash Profile	FW - 140mm
9	1	G100 11		SABİT CAM YATAY KANAT PROFİLİ / Fixed Glass Horizontal Sash Profile	FW - 130mm
10	1	G100 12		ÜST KANAT BİTİŞ PROFİLİ / Top Horizontal Sash Profile	FW - 140mm

İKİ KUMANDADAN BİRİSİ SEÇİLEBİLİR  
YOU CAN CHOOSE ONE OF THEM

AKSESUARLAR / ACCESSORIES			
MİKTAR / Unit	KOD / Code	PROFİL ÇİZİMİ / Drawing	PROFİL TANIMI / Description
1 Adet / Pcs	G100-A1		120 LİK MOTOR / Motor
* 1 Adet / Pcs	G100 - A2		TEKLİ KUMANDA / Single Remote Control
* 1 Adet / Pcs	G100 - A3		ÇOKLU KUMANDA / Multi Remote Control
2 Adet / Pcs	G100 - A4		DIŞLI / Gear
1 Adet / Pcs	G100 - A5		TAMBUR PROFİL ADAPTÖRÜ / Motor Profile Adapter
2 Adet / Pcs	G100 - A6		METAL ASKI ZİNCİRİ / Metal Chain
1 Takım / Set	G100 - A7		MOTOR YAN SACI / Motor Side Cover
2 Adet / Pcs	G100-A8		ZİNCİR ADAPTÖRÜ / Chain Adapter
8 Adet / Pcs	SS AC-03		YAN KILAVUZ TEKER / Side Guide Roller
2 Adet / Pcs	G100 - A10		ZİNCİR ASKI SAÇI / Hanging Part
2 Adet / Pcs	G100 - A11-1		ZİNCİR KORUYUCU / CHAIN GUIDE
1 Adet / Pcs	G100 - A11-2		ZİNCİR KORUYUCU / CHAIN GUIDE
1 Adet / Pcs	G100 - A11-4		RULMAN / ROLLER
1 Adet / Pcs	G100 - A09		GIYOTİN TAMBUR BAŞI / MOTOR PROVISIONS
8XSH+2XFW	KF 67-550		FIRCA FİTİLİ / Brush Gasket
FW	EP2-01		FİTİL / Gasket
5XSW	EP100-01		KAPAMA FİTİLİ / Gasket