

P55

KANATLI AÇILIR PANJUR SİSTEMİ
SASH OPENING SHUTTER SYSTEM

ASISTAL

KESİM TABLOLARI
CUTTING TABLE

PROFİLLER / PROFILES					
NO / Number	ADET / Unit	KOD / Code	PROFİL ÇİZİMİ / Drawing	PROFİL TANIMI / Description	KESİM ÖLÇÜSÜ / Cutting Dimensions
1	2	C55 04		DÜŞEY KASA PROFİLİ / Vertical Frame Profile	FH
2	2	C55 04		YATAY KASA PROFİLİ / Horizontal Frame Profile	FW
3	2	P55- 04		DÜŞEY KANAT PROFİLİ / Vertical Sash Profile	SH=FW - 61,2 mm
4	2	P55-04		YATAY KANAT PROFİLİ / Horizontal Sash Profile	SW=FW - 61,2 mm
5	2	P55-03		ADAPTÖR PROFİLİ / Adapter Profile	SW=FW - 61,2 mm
P55-03 PROFİLİ 4 NOLU P55-04 YATAY KANAT İLE BERABER KESİLMELİ / P55-03 profile must be cut with p55-04 sash profile together					
6	2	P55-02		BAŞLANGIÇ LAMEL PROFİLİ / Slat Profile for End	LB = MW - 30mm
7	TABLO Table	P55-01		LAMEL PROFİLİ / Slat Profile	LS = MW - 18mm
1	12-41			TÜJ PROFİLİ / Espag Rod Profile	SH-35mm

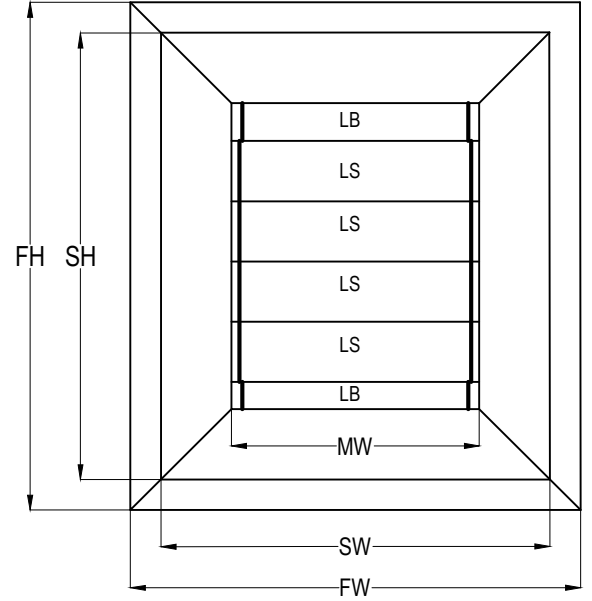

FİTİLLER / GASKETS			
MİKTAR / Unit	KOD / Code	PROFİL ÇİZİMİ / Drawing	PROFİL TANIMI / Description
1 TAKIM / Set	P55-M-01		KANAT AÇILIR MEKANİZMASI / Opening Mechanism
SH≤2000mm 1Adet/Pcs SH>2000mm 2Adet/Pcs	P55-H-01 P55-H-02 P55-H-03 P55-H-04 PH55-H-05+(P55-R-01/P55-R-02) P55-H-06 PH55-H-07+(P55-R-01/P55-R-02)		KOL / Handle
1 Adet/Pcs	ASI-WH-005		DIŞA AÇILIR PENCERE KOLU / Outer Opening Window Handle
2 Takım/Set	M01-SAG_SOL KAPAK		SABİT LAMEL SAĞ_SOL KAPAK (P55 02) RIGHT,LEFT COVER
1 Adet/Pcs	ASI-WH005-58		DIŞA AÇILIR PENCERE KOL DİLİ / Handle Fork
1 Adet/Pcs	ASI-WH 005K		DIŞA AÇILIR PENCERE KOL BAĞLANTI / Outer Opening Handle Connector
2 Adet/Pcs	ASI-RP 001		TÜJ PİMİ / Rod Profile Locking
2 Adet/Pcs	ASI-RS 001		TÜJ PİM KARŞILIĞI / Rod Profile Strike
2 Adet / Pcs	ASI-H 9730		SİSTEM MENTEŞE / System Hinge
2 Adet / Pcs	P55-S-01		KANAT SABİTLEME / Sash Stoper
4 Adet / Pcs	ASI-SB 19.1		KÖŞE GÖNYESİ / Corner Alignment
12 Adet / Pcs	ASI-MO 21		KÖŞE GÖNYESİ / Corner Alignment
4 Adet / Pcs	ASI-PB 2632~ ASI-KT 2319		PİMLİ-PRESS BAĞLANTI / Corner Joint
4 Adet / Pcs	ASI-PB 2326~ ASI-KT 2660		PİMLİ-PRESS BAĞLANTI / Corner Joint
4 Adet / Pcs	ASI-KT 2342		PRESS BAĞLANTI / Corner Joint
mt	EP3-03		KANAT BİNİ FİTİLİ -KANAT KADAR / Sash Gasket (2SH+2SW)

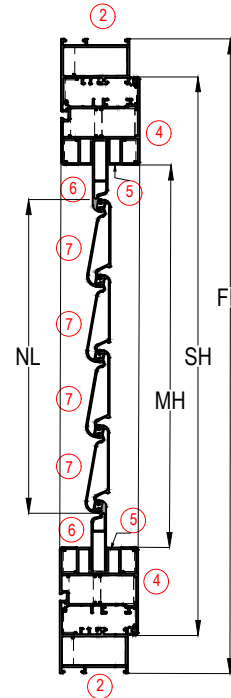

$$MW = FW - (101,5mm \times 2) = FW - 203 \text{ mm}$$

$$MH = FH - (101,5mm \times 2) = FH - 203 \text{ mm}$$

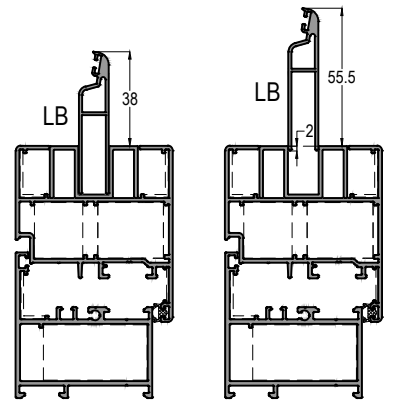
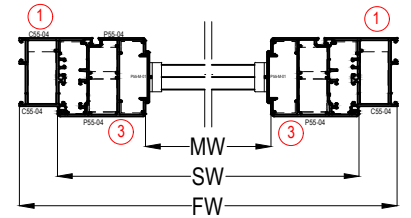

LB BAŞLANGIÇ VE BİTİŞ LAMELİ MİN. 2mm KANAT PROFİLİ İÇİNE MONTE EDİLMELİDİR. P55-M-01 MEKANİZMASI 6MT OLARAK SATILMAKTADIR, AŞAĞIDA VERİLEN TABLODAKİ KANAT İÇİ YÜKSEKLİKLERİNE (MH) GÖRE MEKANİZMA BOYU KESİLİR. YEDEK VERİLEN ALT-ÜST BİTİŞ KAPAKLARI TAKILARAK MEKANİZMA TAMAMLANIR.
LB END SLAT PROFILE MUST BE INSTALL MIN 2MM INTO THE SASH PROFILE. P55-M-01 MECHANISM IS SOLD TO BE 6MT. MECHANISM MUST BE CUT ACCORDING TO THE SASH INSIDE HEIGHT (MH) THAT YOU CAN SEE THE DIMENSIONS AND SLATS PIECES BELOW TABLE . ALSO YOU CAN INSTALL END COVER THAT IS GIVEN YOU WITH MECHANISM ADDITIONALLY.

MEKANİZMA BOYU VE KAPAK SAYISI HESAPLAMA / Calculate Mechanism Cutting and Slat Cover Pieces

MH = MAX MEKANİZMA BOYU MH = Max Mechanism Height	460	520	580	640	700	760	820	880	940	1000	1060	1120	1180	1240	1300	1360	1420	1480	1540	1600	1660	1720	1780	1840	1900	1960	2020
NL = MAX LAMEL SAYISI = Max Slat Pieces	6	7	8	9	10	11	12	13	14	15	16	17	18	19	20	21	22	23	24	25	26	27	28	29	30	31	32

PROFİLLER / PROFILES					
NO / Number	ADET / Unit	KOD / Code	PROFİL ÇİZİMİ / Drawing	PROFİL TANIMI / Description	KESİM ÖLÇÜSÜ / Cutting Dimensions
1	2	C55-04		DÜŞEY KASA PROFİLİ / Vertical Frame Profile	FH
2	2	C55-04		YATAY KASA PROFİLİ / Horizontal Frame Profile	FW
3	4	P55-04		DÜŞEY KANAT PROFİLİ / Vertical Sash Profile	SH=FW - 61,2 mm
4	4	P55-04		YATAY KANAT PROFİLİ / Horizontal Sash Profile	SW=FW - (61,2+5)/2 mm
5	4	P55-03		ADAPTÖR PROFİLİ / Adapter Profile	SW=FW - (61,2+5)/2 mm
P55-03 PROFİLİ 4 NOLU P55-04 YATAY KANAT İLE BERABER KESİLMELİ / P55-03 profile must be cut with p55-04 sash profile together					
6	4	P55-02		BAŞLANGIÇ LAMEL PROFİLİ / Slat Profile for End	LB = MW - 30mm
7	TABLO Table	P55-01		LAMEL PROFİLİ / Slat Profilii	LS = MW - 18mm
8	1	C55-41		ÇİFT KANAT ADAPTÖR PROFİLİ / Adapter Profile	SH - 68,6mm
	2	12-41		TİJ PROFİLİ / Espag Rod Profile	SH-35mm

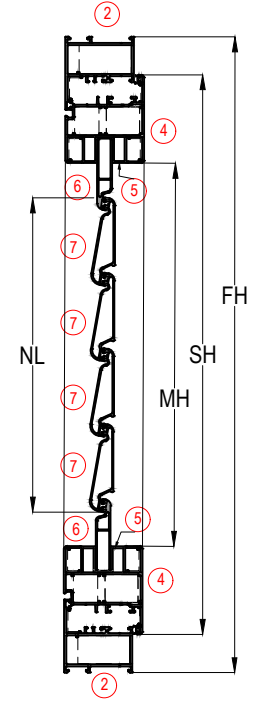

FİTİLLER / GASKETS			
MİKTAR / Unit	KOD / Code	PROFİL ÇİZİMİ / Drawing	PROFİL TANIMI / Description
2 TAKIM / Set	P55-M-01		KANAT AÇILIR MEKANİZMASI / Opening Mechanism
SH≤2000mm 2Adet/Pcs SH≥2000mm 4Adet/Pcs	P55-H-01 P55-H-02 P55-H-03 P55-H-04 PH55-H-05+(P55-R-01/P55-R-02) P55-H-06 PH55-H-07+(P55-R-01/P55-R-02)		KOL / Handle
2 Adet/Pcs	ASI-WH-005		DIŞA AÇILIR PENCERE KOLU / Outer Opening Window Handle
2 Adet/Pcs	ASI-WH005-58		DIŞA AÇILIR PENCERE KOL DİLİ / Handle Fork
2 Adet/Pcs	ASI-WH 005K		DIŞA AÇILIR PENCERE KOL BAĞLANTI / Outer Opening Handle Connector
2 Adet/Pcs	ASI-RP 001		TİJ PİMİ / Rod Profile Locking
2 Adet/Pcs	ASI-RS 001		TİJ PİM KARŞILIĞI / Rod Profile Strike
4 Takım/Set	M01-SAG_SOL KAPAK		SABİT LAMEL SAĞ_SOL KAPAK (P55 02) RIGHT,LEFT COVER
4 Adet / Pcs	ASI-H 9730		SİSTEM MENTEŞE / System Hinge
1 Takım / Set	ASI-KA M108		EKSENEL KOL KİLİTLEME / Locking For Passive Sash
1 Takım / Set	C55 HOK		ADAPTÖR KAPAĞI / Adapter Cover
2 Adet / Pcs	P55-S-01		KANAT SABİTLEME / Sash Stoper
8 Adet / Pcs	ASI-SB 19.1		KÖŞE GÖNYESİ / Corner Alignment
20 Adet / Pcs	ASI-MO 21		KÖŞE GÖNYESİ / Corner Alignment
8 Adet / Pcs	ASI-PB 2632~ ASI-KT 2319		PİMLİ-PRESS BAĞLANTI / Corner Joint
8 Adet / Pcs	ASI-PB 2326~ ASI-KT 2660		PİMLİ-PRESS BAĞLANTI / Corner Joint
4 Adet / Pcs	ASI-KT 2342		PRESS BAĞLANTI / Corner Joint
mt	EP3-03		KANAT BİNİ FİTİLİ -KANAT KADAR / Sash Gasket (4SH+4SW)

$$MW = FW - (101,5mm \times 2)$$

$$= FW - 203 mm$$

$$MH = FH - (101,5mm \times 2)$$

$$= FH - 203 mm$$

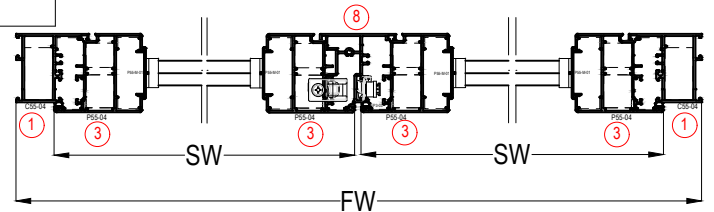
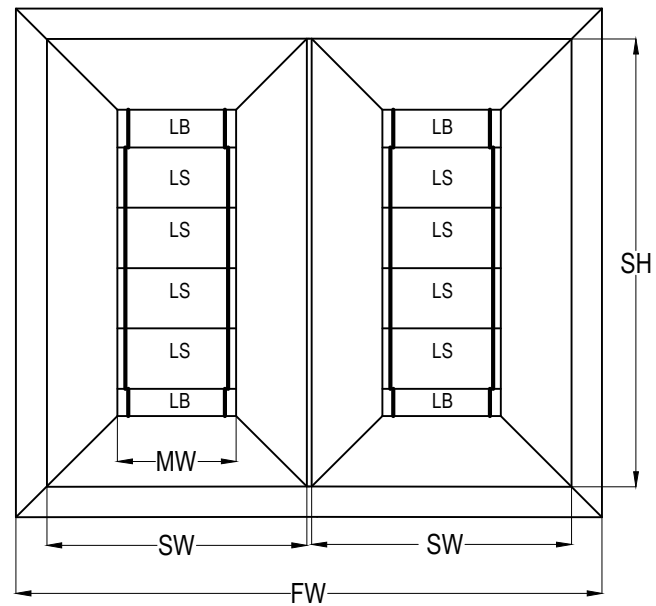

PROFİLLER / PROFILES					
NO / Number	ADET / Unit	KOD / Code	PROFİL ÇİZİMİ / Drawing	PROFİL TANIMI / Description	KESİM ÖLÇÜSÜ / Cutting Dimensions
1	2	AS55 02		DÜŞEY KASA PROFİLİ / Vertical Frame Profile	FH
2	1	AS55 02		YATAY KASA PROFİLİ / Horizontal Frame Profile	FW
3	6	P55- 04		DÜŞEY KANAT PROFİLİ / Vertical Sash Profile	SH=FW - 154.7 mm
4.1	4	P55-04		YATAY KANAT PROFİLİ / Horizontal Frame Profile	SW1=(FW-(A-1)X5)-(2XS2.7)+20mm
4.2	2	P55-04		YATAY KANAT PROFİLİ / Horizontal Frame Profile	SW2=SW1-20mm
5	4	P55-03		ADAPTÖR PROFİLİ / Adapter Profile	SW1-25
5.1	2	P55-03		ADAPTÖR PROFİLİ / Adapter Profile	SW2-25
P55-03 PROFİLİ 4 NOLU P55-04 YATAY KANAT İLE BERABER KESİLMELİ / P55-03 profile must be cut with p55-04 sash profile together					
6	6	P55-02		BAŞLANGIÇ LAMEL PROFİLİ / Slat Profile for End	LB = MW - 30mm
7	TABLO Table	P55-01		LAMEL PROFİLİ / Slat Profili	LS = MW - 18mm
8	2	C55-41		ÇİFT KANAT ADAPTÖR PROFİLİ / Adapter Profile	SH - 68,6mm
9	1	C55 31		ETEK PROFİLİ / Bottom Plate	FW-117,4

A : KANAT MİKTARI
A : SASH AMOUNT

FİTİLLER / GASKETS			
MİKTAR / Unit	KOD / Code	PROFİL ÇİZİMİ / Drawing	PROFİL TANIMI / Description
3 TAKIM / Set	P55-M-01		KANAT AÇILIR MEKANİZMASI / Opening Mechanism
SH≤2000mm 3Adet/Pcs SH≥2000mm 6Adet/Pcs	P55-H-01 P55-H-02 P55-H-03 P55-H-04 PH55-H-05+(P55-R-01/P55-R-02) P55-H-06 PH55-H-07+(P55-R-01/P55-R-02)		KOL / Handle
2 Takım / Set	C55 HOK		ADAPTÖR KAPAĞI / Adapter Cover
2 Adet / Pcs	P55-S-01		KANAT SABİTLEME / Sash Stoper
12 Adet / Pcs	ASI-SB 19.1		KÖŞE GÖNYESİ / Corner Alignment
6 Takım/Set	M01-SAG_SOL KAPAK		SABİT LAMEL SAĞ SOL KAPAK (P55 02) RIGHT/LEFT COVER
24 Adet / Pcs	ASI-MO 21		KÖŞE GÖNYESİ / Corner Alignment
12 Adet / Pcs	ASI-PB 2632~ ASI-KT 2319		PİMLİ-PRESS BAĞLANTI / Corner Joint
12 Adet / Pcs	ASI-PB 2326~ ASI-KT 2660		PİMLİ-PRESS BAĞLANTI / Corner Joint
2 Adet / Pcs	ASI-KT 4342		PRESS BAĞLANTI / Corner Joint
2 Adet / Pcs	ASI-DB 9164		DİK BAĞLANTI / T Joint
2 Adet / Pcs	FUJİ-2000		AYARLI KÖŞE GÖNYESİ / Corner Alignment
mt	EP3-03		KANAT BİNİ FİTİLİ -KANAT KADAR / Sash Gasket (6SH+6SW)

Max. Kanat Ağırlığı 80 kg.

Max. Sash Weight 80 kg.

AKSESUARLAR / HARDWARE		
MİKTAR / Unit	KOD / Code	PROFİL TANIMI / Description
1 Takım / Set	V.5702.0402	KÖŞE HAREKET GRUBU
1 Takım / Set	V.5705.01.02	KOL BAĞLANTI
1 Takım / Set	V.5707.0102	KAVRAMA KARŞILIĞI
1 Takım / Set	V.5708.0116	KANAT KALDIRMA KARŞILIĞI
1 Takım / Set	V.5709.0102	SÜRGÜ KARŞILIK
1 Takım / Set	V.5704.0202	ÇİFT KANAT SÜRGÜSÜ
1 Takım / Set	V5705.0002	SÜRME ARABA GRUBU
3 Takım / Set	V.4700.0116	SÜRME ARABA GRUBU
6 Takım / Set	V.4701.0402	KATLANIR SÜRME MENTEŞE
6 Takım / Set	V.4701.0416	KATLANIR SÜRME MENTEŞE KAPAK
1 Takım / Set	V.4702.0116	KATLANIR SÜRME RAY GRUBU 3MT.
2 Takım / Set	V.4704.0116	KATLANIR SÜRME KANAT SABİTLEME

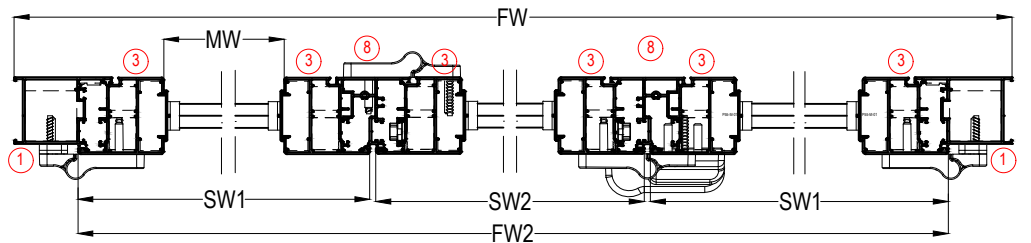
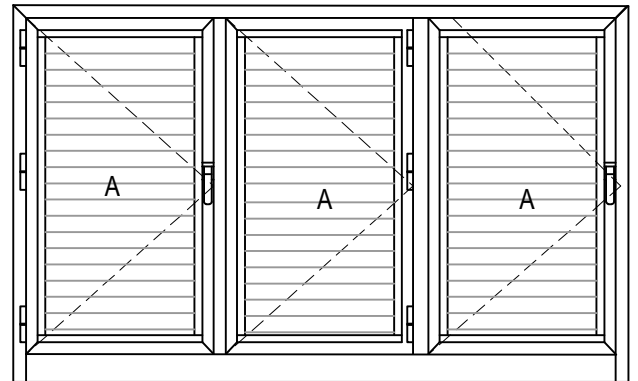
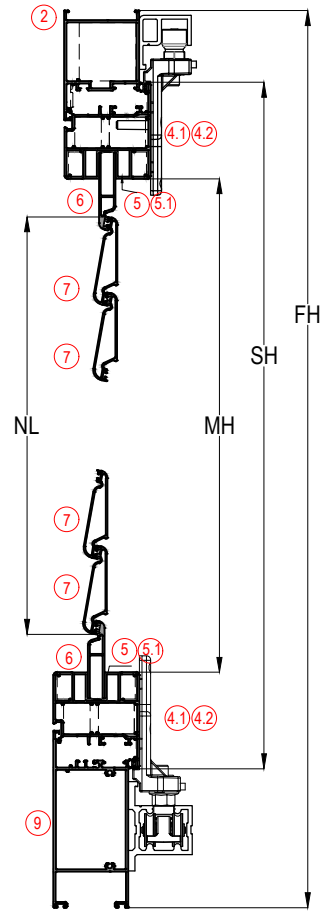

PROFİLLER / PROFILES					
NO / Number	ADET / Unit	KOD / Code	PROFİL ÇİZİMİ / Drawing	PROFİL TANIMI / Description	KESİM ÖLÇÜSÜ / Cutting Dimensions
1	2	AS55 02		DÜŞEY KASA PROFİLİ / Vertical Frame Profile	FH
2	1	AS55 02		YATAY KASA PROFİLİ / Horizontal Frame Profile	FW
3	6	P55- 04		DÜŞEY KANAT PROFİLİ / Vertical Sash Profile	SH=FW - 154,7 mm
4.1	4	P55-04		YATAY KANAT PROFİLİ / Horizontal Frame Profile	FW1=((FW-(A-1)XS)-(2XS2,7)+9)N
4.2	2	P55-04		YATAY KANAT PROFİLİ / Horizontal Frame Profile	SW2=SW1-40,3mm
5	4	P55-03		ADAPTÖR PROFİLİ / Adapter Profile	SW1-25
5.1	2	P55-03		ADAPTÖR PROFİLİ / Adapter Profile	SW2-25
				P55-03 PROFİLİ 4 NOLU P55-04 YATAY KANAT İLE BERABER KESİLMELİ / P55-03 profile must be cut with p55-04 sash profile together	
6	6	P55-02		BAŞLANGIÇ LAMEL PROFİLİ / Slat Profile for End	LB = MW - 30mm
7	TABLO Table	P55-01		LAMEL PROFİLİ / Slat Profili	LS = MW - 18mm
8	2	C55-41		ÇİFT KANAT ADAPTÖR PROFİLİ / Adapter Profile	SH - 68,6mm
9	1	C55 31		ETEK PROFİLİ / Bottom Plate	FW-117,4

A: KANAT MİKTARI
A: SASH AMOUNT

FİTİLLER / GASKETS			
MİKTAR / Unit	KOD / Code	PROFİL ÇİZİMİ / Drawing	PROFİL TANIMI / Description
3 TAKIM / Set	P55-M-01		KANAT AÇILIR MEKANİZMASI / Opening Mechanism
SH≤2000mm 3Adet/Pcs SH≥2000mm 6Adet/Pcs	P55-H-01 P55-H-02 P55-H-03 P55-H-04 PH55-H-05+(P55-R-01/P55-R-02) P55-H-06 PH55-H-07+(P55-R-01/P55-R-02)		KOL / Handle
2 Takım / Set	C55 HOK		ADAPTÖR KAPAĞI / Adapter Cover
6 Takım/Set	M01-SAG_SOL KAPAK		SABİT LAMEL SAĞ_SOL KAPAK (P55 02) RIGHT,LEFT COVER
2 Adet / Pcs	P55-S-01		KANAT SABİTLEME / Sash Stoper
12 Adet / Pcs	ASI-SB 19.1		KÖŞE GÖNYESİ / Corner Alignment
24 Adet / Pcs	ASI-MO 21		KÖŞE GÖNYESİ / Corner Alignment
12 Adet / Pcs	ASI-PB 2632~ ASI-KT 2319		PİMLİ-PRESS BAĞLANTI / Corner Joint
12 Adet / Pcs	ASI-PB 2326~ ASI-KT 2660		PİMLİ-PRESS BAĞLANTI / Corner Joint
2 Adet / Pcs	ASI-KT 4342		PRESS BAĞLANTI / Corner Joint
2 Adet / Pcs	ASI-DB 9164		DİK BAĞLANTI / T Joint
2 Adet / Pcs	FUJI-2000		AYARLI KÖŞE GÖNYESİ / Corner Alignment
mt	EP3-03		KANAT BİNİ FİTİLİ -KANAT KADAR / Sash Gasket (6SH+6SW)

Max. Kanat Ağırlığı 80 kg.

Max. Sash Weight 80 kg.

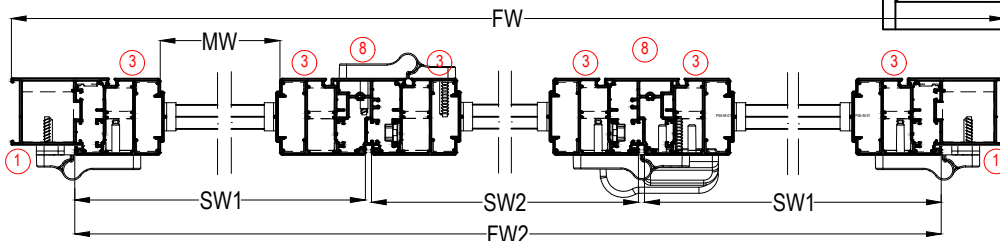

AKSESUARLAR / HARDWARE		
MİKTAR / Unit	KOD / Code	PROFİL TANIMI / Description
4 Takım / Set	V.5702.0402	KÖŞE HAREKET GRUBU
2 Takım / Set	V.5705.0102	KOL BAĞLANTI
4 Takım / Set	V.5707.0102	KAVRAMA KARŞILIĞI
2 Takım / Set	V.5708.0116	KANAT KALDIRMA KARŞILIĞI
2 Takım / Set	V.5709.0102	SÜRGÜ KARŞILIK
2 Takım / Set	V.5704.0202	ÇİFT KANAT SÜRGÜSÜ
1 Takım / Set	V.5700.5016	ÇİFT KANAT TAKIMI
1 Takım / Set	V5705.0002	SÜRME ARABA GRUBU
3 Takım / Set	V.4700.0116	SÜRME ARABA GRUBU KAPAK
3 Takım / Set	V.4701.0402	KATLANIR SÜRME MENTEŞE
3 Takım / Set	V.4701.0416	KATLANIR SÜRME MENTEŞE KAPAK
1 Takım / Set	V.4702.0116	KATLANIR SÜRME RAY GRUBU 3MT.
2 Takım / Set	V.4704.0116	KATLANIR SÜRME KANAT SABİTLEME

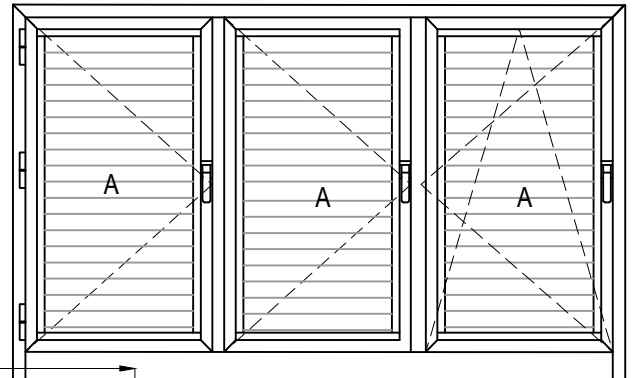
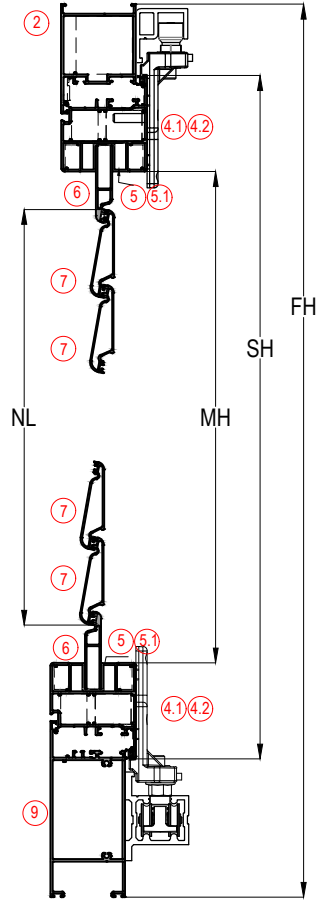

A: KANAT MİKTARI A: SASH AMOUNT		PROFİLLER / PROFILES			
NO / Number	ADET / Unit	KOD / Code	PROFİL ÇİZİMİ / Drawing	PROFİL TANIMI / Description	KEŞİM ÖLÇÜSÜ / Cutting Dimensions
1	2	AS55 02		DÜŞEY KASA PROFİLİ / Vertical Frame Profile	FH
2	1	AS55 02		YATAY KASA PROFİLİ / Horizontal Frame Profile	FW
3	8	P55- 04		DÜŞEY KANAT PROFİLİ / Vertical Sash Profile	SH=FW - 154,7 mm
4.1	4	P55-04		YATAY KANAT PROFİLİ / Horizontal Frame Profile	SW1=(FW-(A-1)X5)-(2X52,7)+26mm
4.2	2	P55-04		YATAY KANAT PROFİLİ / Horizontal Frame Profile	SW2=SW1-20mm
4.3	2	P55-04		YATAY KANAT PROFİLİ / Horizontal Frame Profile	SW3=SW1-40,3mm
5	4	P55-03		ADAPTÖR PROFİLİ / Adapter Profile	SW1-25
5.1	2	P55-03		ADAPTÖR PROFİLİ / Adapter Profile	SW2-25
5.2	2	P55-03		ADAPTÖR PROFİLİ / Adapter Profile	SW3-25
P55-03 PROFİLİ 4 NOLU P55-04 YATAY KANAT İLE BERABER KESİLMELİ / P55-03 profile must be cut with p55-04 sash profile together					
6	8	P55-02		BAŞLANGIÇ LAMEL PROFİLİ / Slat Profile for End	LB = MW - 30mm
7	TABLO Table	P55-01		LAMEL PROFİLİ / Slat Profili	LS = MW - 18mm
8	3	C55-41		ÇİFT KANAT ADAPTÖR PROFİLİ / Adapter Profile	SH - 68,6mm
9	1	C55 31		ETEK PROFİLİ / Bottom Plate	FW-117,4

AKSESUARLAR / HARDWARE		
MİKTAR / Unit	KOD / Code	PROFİL TANIMI / Description
4 Takım / Set	V.5702.0402	KÖŞE HAREKET GRUBU
2 Takım / Set	V.5705.0102	KOL BAĞLANTI
4 Takım / Set	V.5707.0102	KAVRAMA KARŞILIĞI
2 Takım / Set	V.5708.0116	KANAT KALDIRMA KARŞILIĞI
2 Takım / Set	V.5709.0102	SÜRGÜ KARŞILIK
2 Takım / Set	V.5704.0202	ÇİFT KANAT SÜRGÜSÜ
1 Takım / Set	V.5700.5016	ÇİFT KANAT TAKIMI
1 Takım / Set	V4705.0002	SÜRME ARABA GRUBU
3 Takım / Set	V.4700.0116	SÜRME ARABA GRUBU KAPAK
6 Takım / Set	V.4701.0402	KATLANIR SÜRME MENTEŞE
6 Takım / Set	V.4701.0416	KATLANIR SÜRME MENTEŞE KAPAK
1 Takım / Set	V.4702.0216	KATLANIR SÜRME RAY GRUBU 3MT.
2 Takım / Set	V.4704.0116	KATLANIR SÜRME KANAT SABİTLEME

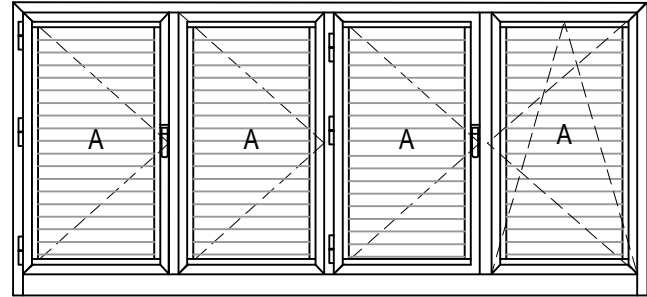
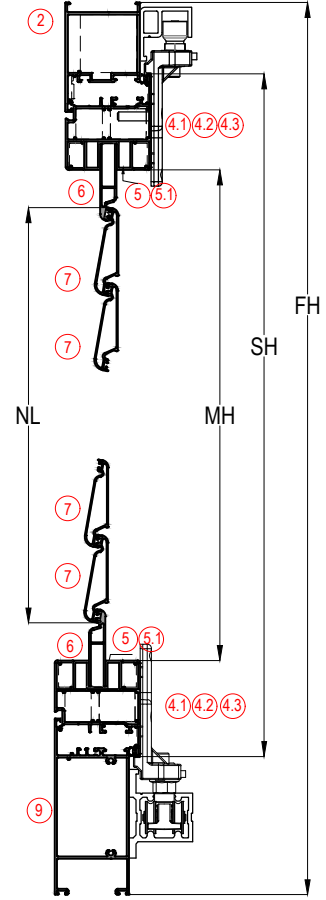

FİTİLLER / GASKETS			
MİKTAR / Unit	KOD / Code	PROFİL ÇİZİMİ / Drawing	PROFİL TANIMI / Description
4 TAKIM / Set	P55-M-01		KANAT AÇILIR MEKANİZMASI / Opening Mechanism
SH≤2000mm 4Adet/Pcs SH≥2000mm 8Adet/Pcs	P55-H-01 P55-H-02 P55-H-03 P55-H-04 PH55-H-05+(P55-R-01/P55-R-02) P55-H-06 PH55-H-07+(P55-R-01/P55-R-02)		KOL / Handle
3 Takım / Set	C55 HOK		ADAPTÖR KAPAĞI / Adapter Cover
2 Adet / Pcs	P55-S-01		KANAT SABİTLEME / Sash Stopper
8 Takım/Set	M01-SAG_SOL KAPAK		SABİT LAMEL SAĞ_SOL KAPAK (P55 02) RIGHT,LEFT COVER
16 Adet / Pcs	ASI-SB 19.1		KÖŞE GÖNYESİ / Corner Alignment
32 Adet / Pcs	ASI-MO 21		KÖŞE GÖNYESİ / Corner Alignment
16 Adet / Pcs	ASI-PB 2632~ ASI-KT 2319		PİMLİ-PRESS BAĞLANTI / Corner Joint
16 Adet / Pcs	ASI-PB 2326~ ASI-KT 2660		PİMLİ-PRESS BAĞLANTI / Corner Joint
2 Adet / Pcs	ASI-KT 4342		PRESS BAĞLANTI / Corner Joint
2 Adet / Pcs	ASI-DB 9164		DİK BAĞLANTI / T Joint
2 Adet / Pcs	FUJI-2000		AYARLI KÖŞE GÖNYESİ / Corner Alignment
mt	EP3-03		KANAT BİNİ FİTİLİ -KANAT KADAR / Sash Gasket (8SH+8SW)

Max. Kanat Ağırlığı 80 kg.

Max. Sash Weight 80 kg.

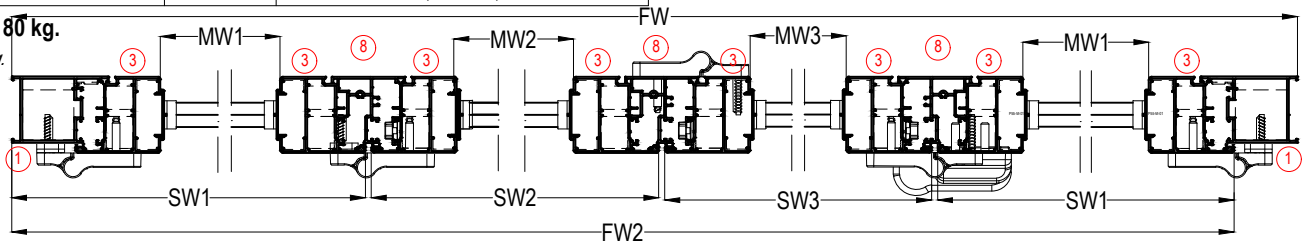

P55-H-01 VE P55-H-02 KOL MONTAJI

ASSEMBLY FOR HANDLE P55-H-01 and P55-H-02

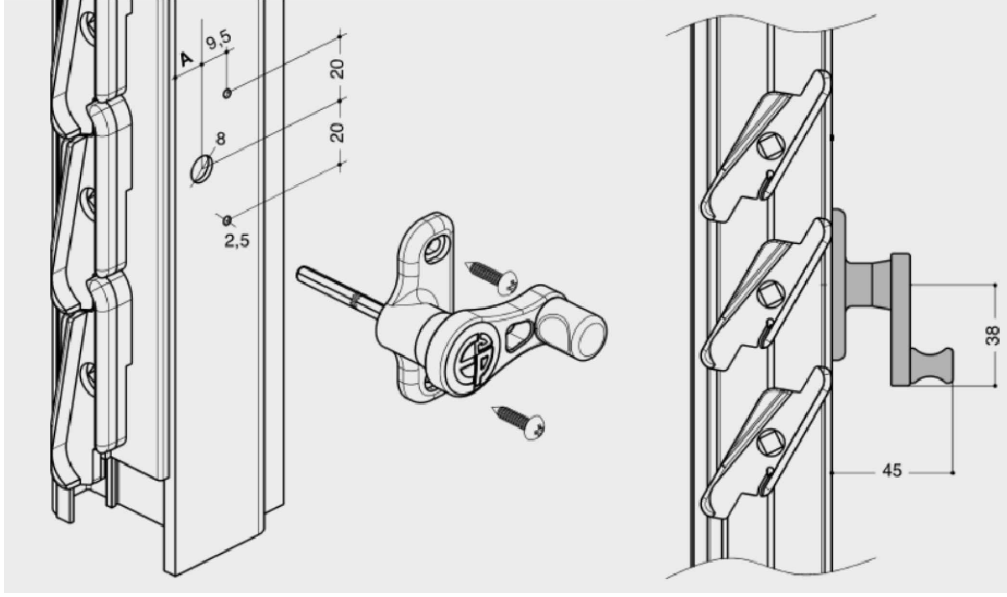
**P55-H-03 VE P55-H-04 KOL MONTAJI**

ASSEMBLY FOR HANDLE P55-H-03 and P55-H-04

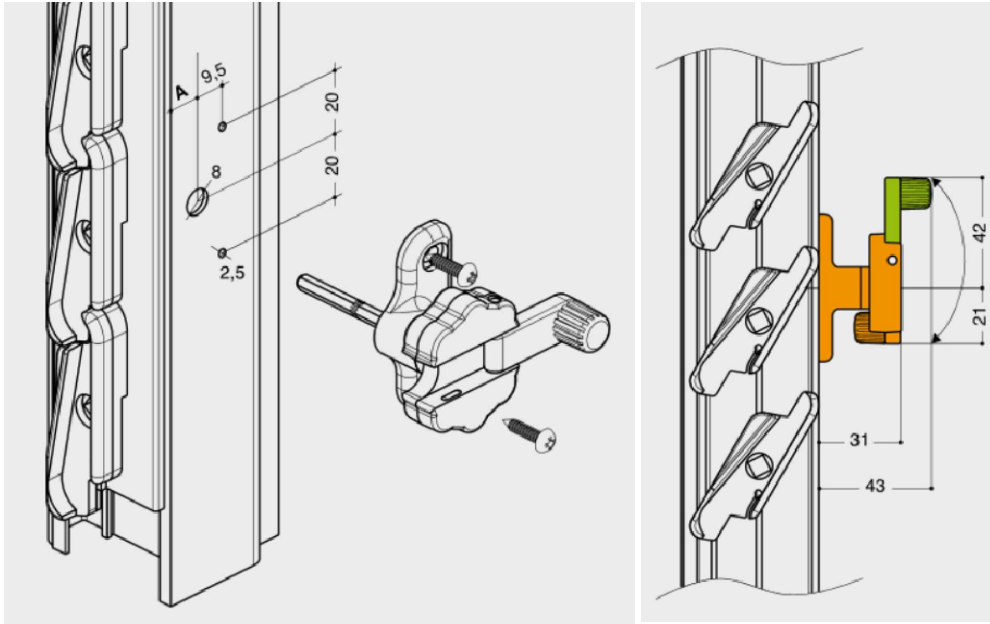
**KOL DELİK YERLERİ AÇILMASI / Drilling for Handles**

	A
P55-H-01	9 mm
P55-H-02	8 mm
P55-H-03	9 mm
P55-H-04	8 mm

P55-H-05 MONTAJI

ASSEMBLY FOR HANDLE P55-H-05

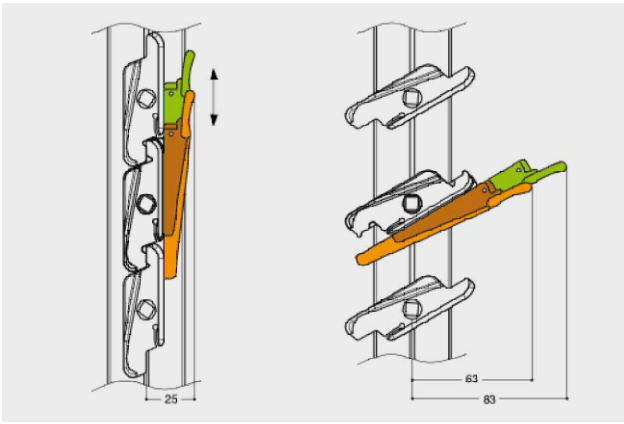
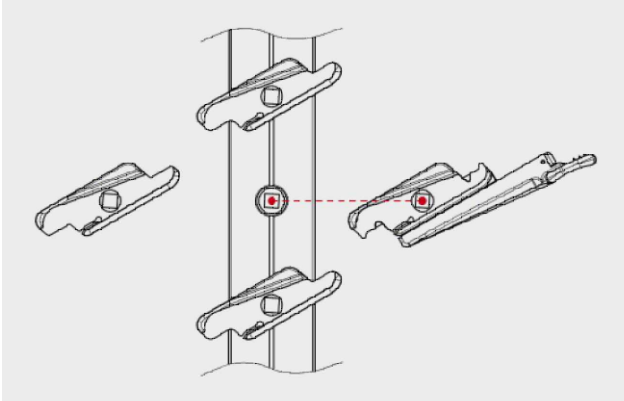

P55-H-07 MONTAJI

ASSEMBLY FOR HANDLE P55-H-07

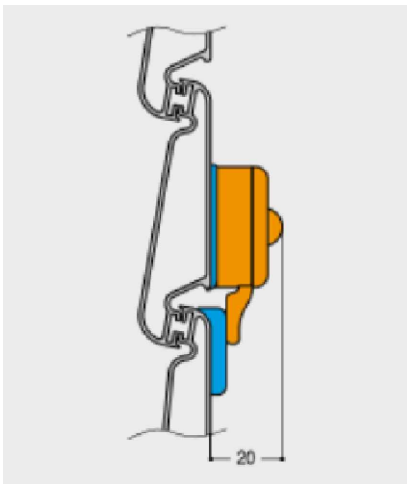
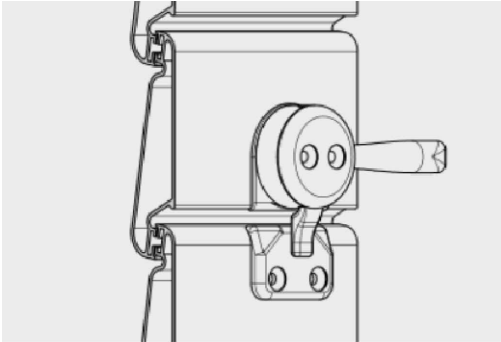

P55-H-06 MONTAJI

ASSEMBLY FOR HANDLE P55-H-05

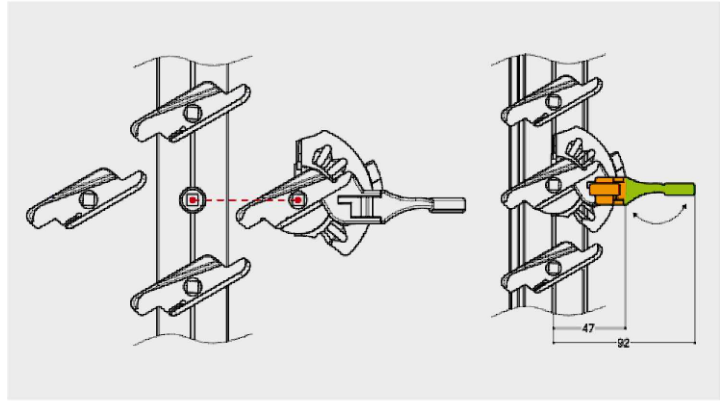

P55-R-01 MONTAJI

ASSEMBLY FOR REGULATOR P55-R-01

P55-R-01

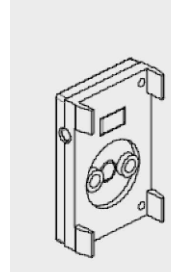

P55-M-01

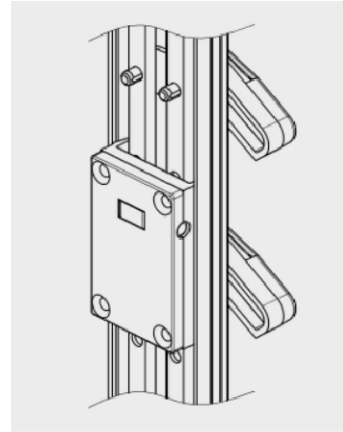

P55-R-02 MONTAJI

ASSEMBLY FOR REGULATOR P55-R-02

P55-M-01

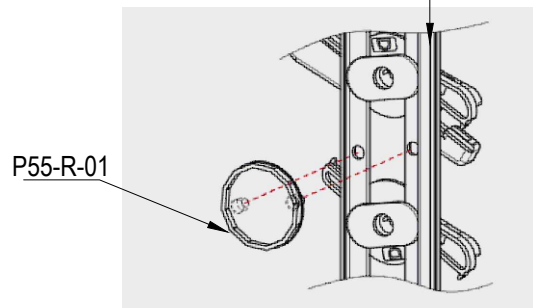

**P55-R-01 VE P55-R-02 SADECE
P55-H-05 VE P55-H-07 KOLLARI İÇİN
UYGUNDUR,**

*REGULATOR P55-R-01 and P55-R-02 ARE SUITABLE
FOR HANDLES P55-H-05 and P55-H-07*

P55-M-01

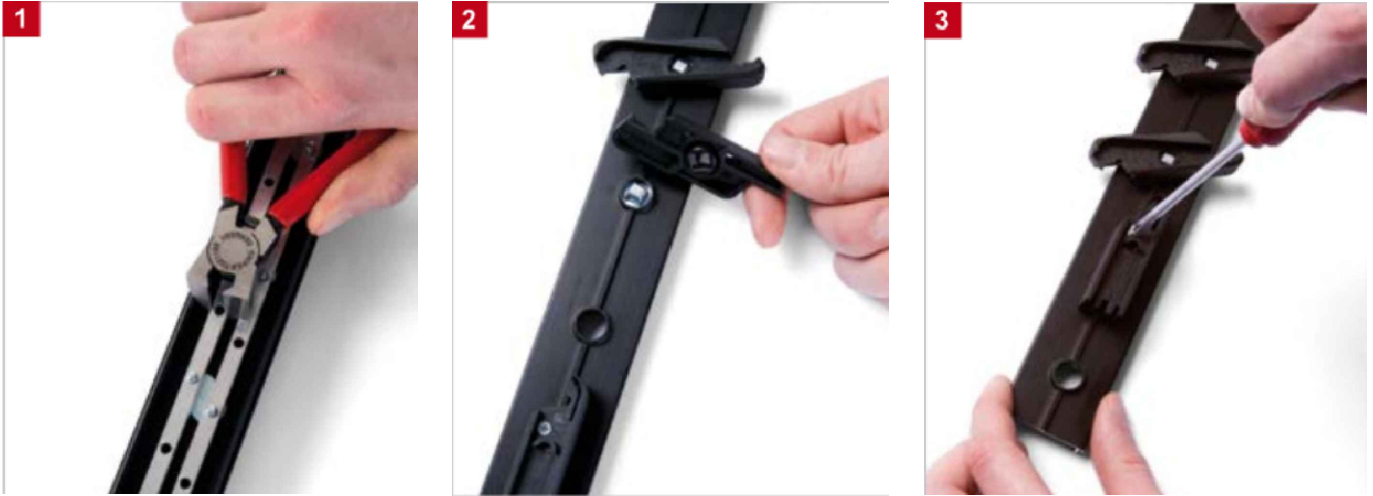

P55-M-01 MEKANİZMASI KULLANIM BOYUNA GÖRE 6MT DEN KESİLİR. ÖNCE LAMEL ADEDİ VERİLEN TABLODAN BELİRLENİR. ÖLÇÜYE GÖRE KESİM İŞLEMİ İÇİN ARKA KISIMDA YER ALAN METAL BAĞLANTILAR, KAPAK BAĞLANTI NOKTASINDAN YAKLAŞIK 1cm (1) YUKARIDAN KESİLİR. BELİRLENEN SAYIDAN FAZLA OLAN LAMEL KAPAKLARI ÇIKARILIR (2), DAHA SONRA BİTİŞ KAPAKLARININ YERİ DEĞİŞTİRİLEREK İSTENEN ÖLÇÜYE GEİTİRİLİR (3). FAZLA KISIM KESİLİR.

P55-M-01 MECHANISM CUT ACCORDING TO THE PROJECT DIMENSION FROM THE 6 MT. FIRSTLY CUT THE RUNNERS AT APPROXIMATELY 1cm FROM THE JOINT (1), REMOVE THE UNNECESSARY SLATS (2). UNSCREW THE COMPENSATION ELEMENT FROM ITS INITIAL POSITION AND TIGHTEN IT INTO THE HOLE NEXT TO THE LAST SLAT HOLDER. CUT THE EXCESS PART OF BAR.



KANATLI AÇILIR PANJUR KURULUMU İÇİN ÖNCELİKLE KASA (C55-04) VE KANAT (P55-04) PROFİLLERİ KÖŞELERİ 45° OLARAK BİRLEŞTİRİLİR. DAHA SONRA P55-03 PROFİLİ KANAT ALT-ÜST YATAY BOŞLUĞA YERLEŞTİRİLİR. P55-M-01 MEKANİZMASI İSTENİLEN ÖLÇÜDE KESİLDİKTEN SONRA KANAT İÇİN DÜŞEY BOŞLUKLARA YERLEŞTİRİLİR. SON OLARAK ÖLÇÜSÜNDE KESİLEN P55-01 VE P55-02 LAMELLERİ MEKANİZMAYA SÜRÜLEREK YERLEŞTİRİLİR.

FOR ASSEMBLY SASH OPENING SHUTTER SYSTEM, FIRSTLY THE CASE (C55-04) AND THE SASH (P55-04) PROFILES CORNERS MUST BE JOINT TO BE 45°. AFTER THAT P55-03 PROFILE MUST BE INSTALL INSIDE THE SASH BY THE HORIZONTALLY TOP AND BOTTOM. THE P55-M-01 MECHANISM IS PLACED IN VERTICAL SPACES FOR SASH SIDES. P55-01 AND P55-02 LAMELS CUT AT THE SIZE OF THE SURFACE ARE PLACED THROUGH MECHANISM.

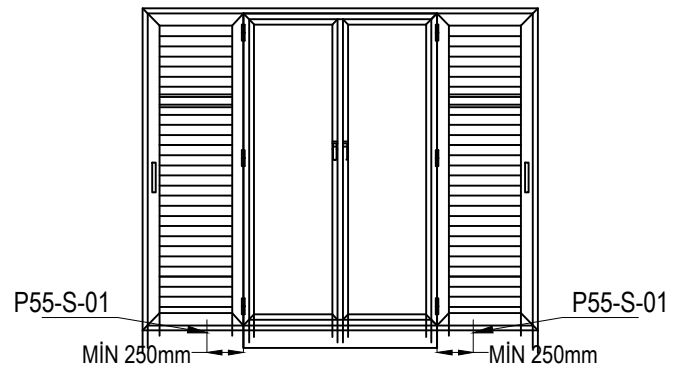

P55-S-01

