

G800

CAM BAZA KÜPEŞTE SİSTEMLERİ
GLASS RAILING SYSTEMS

ASISTAL

CAM BAZA KÜPEŞTE SİSTEMLERİ
GLASS RAILING SYSTEMS

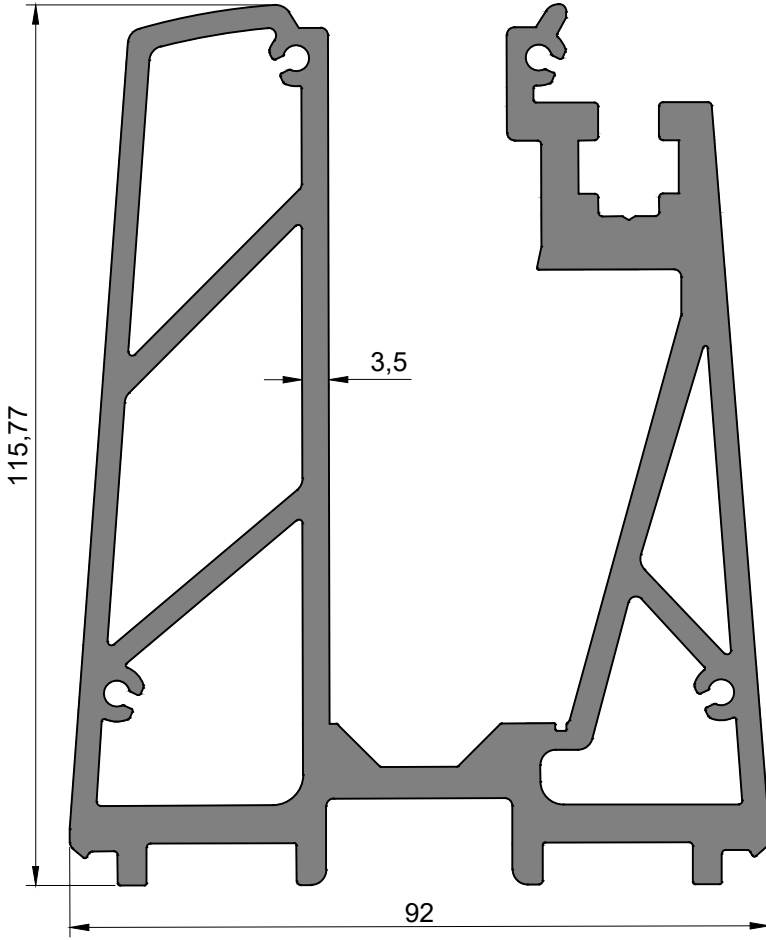

1270	
CAM BAZA PROFİLİ GLASS RAILING PROFILE	AĞIRLIK / Weight
	6,908 kg/mt

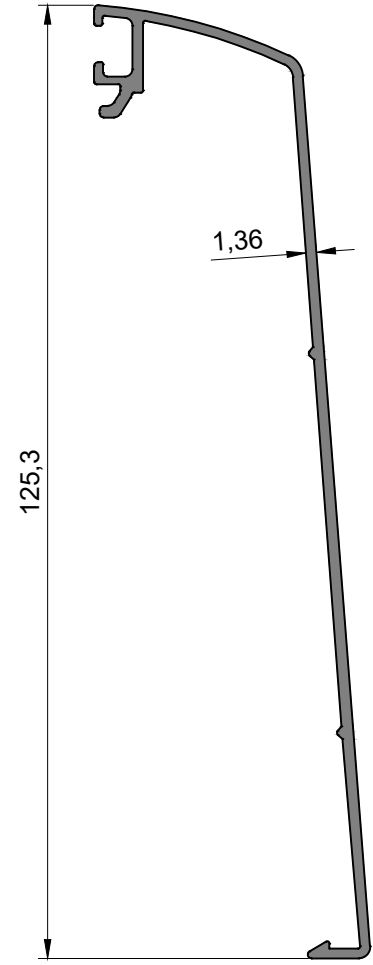

1273	
KAPAK PROFİLİ COVER PROFILE	AĞIRLIK / Weight
	0,662 kg/mt

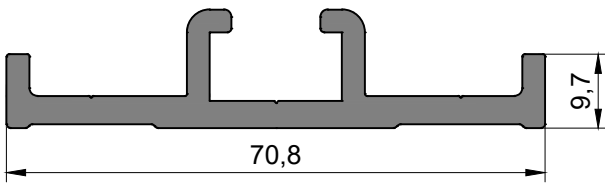

1271	
RAY PROFİLİ RAIL PROFILE	AĞIRLIK / Weight
	1,045kg/mt

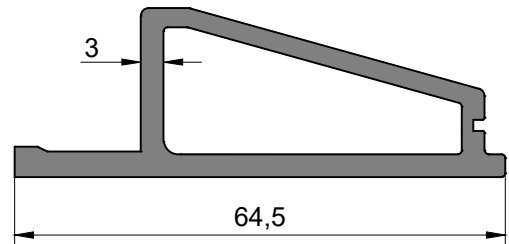

1272	
CAM SIKIŞTIRMA PRO. GLASS COMPRESSION PROFILE	AĞIRLIK / Weight
	1,046 kg/mt

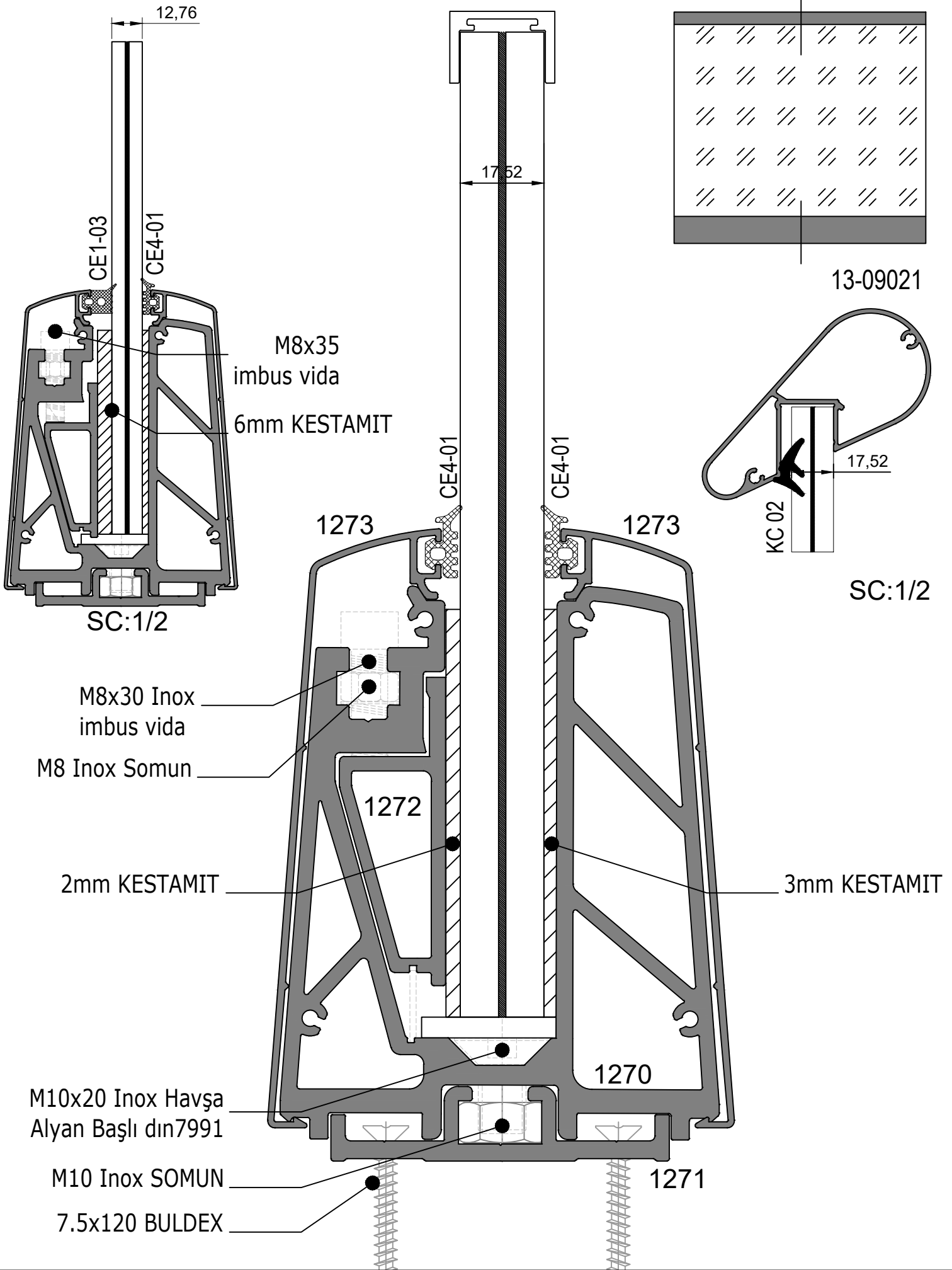

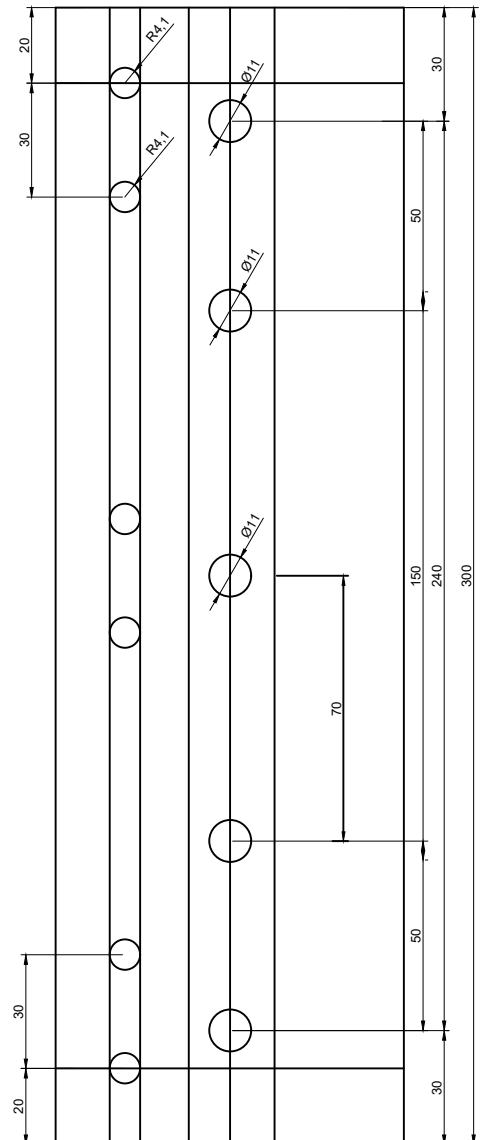
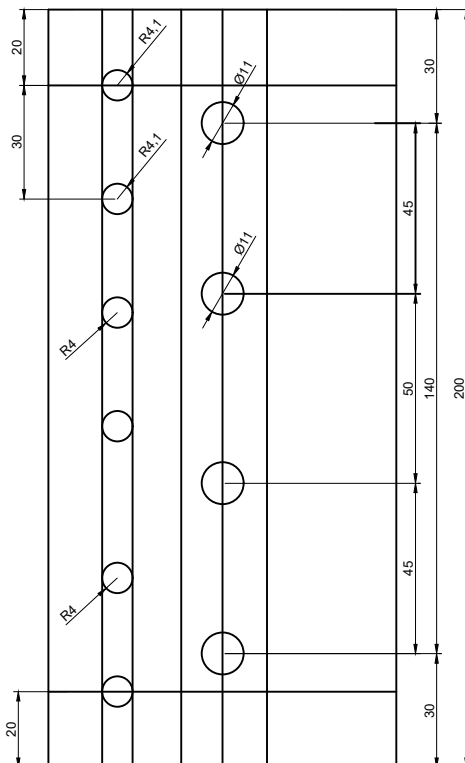
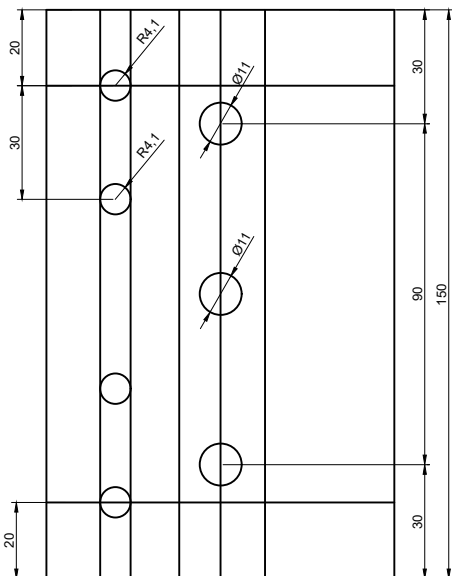
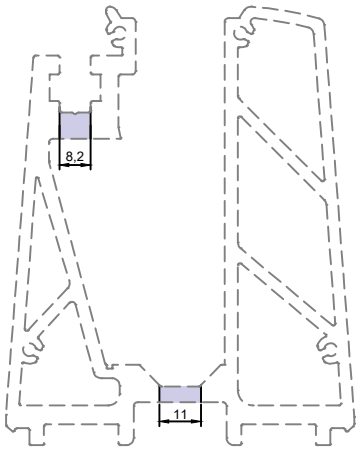
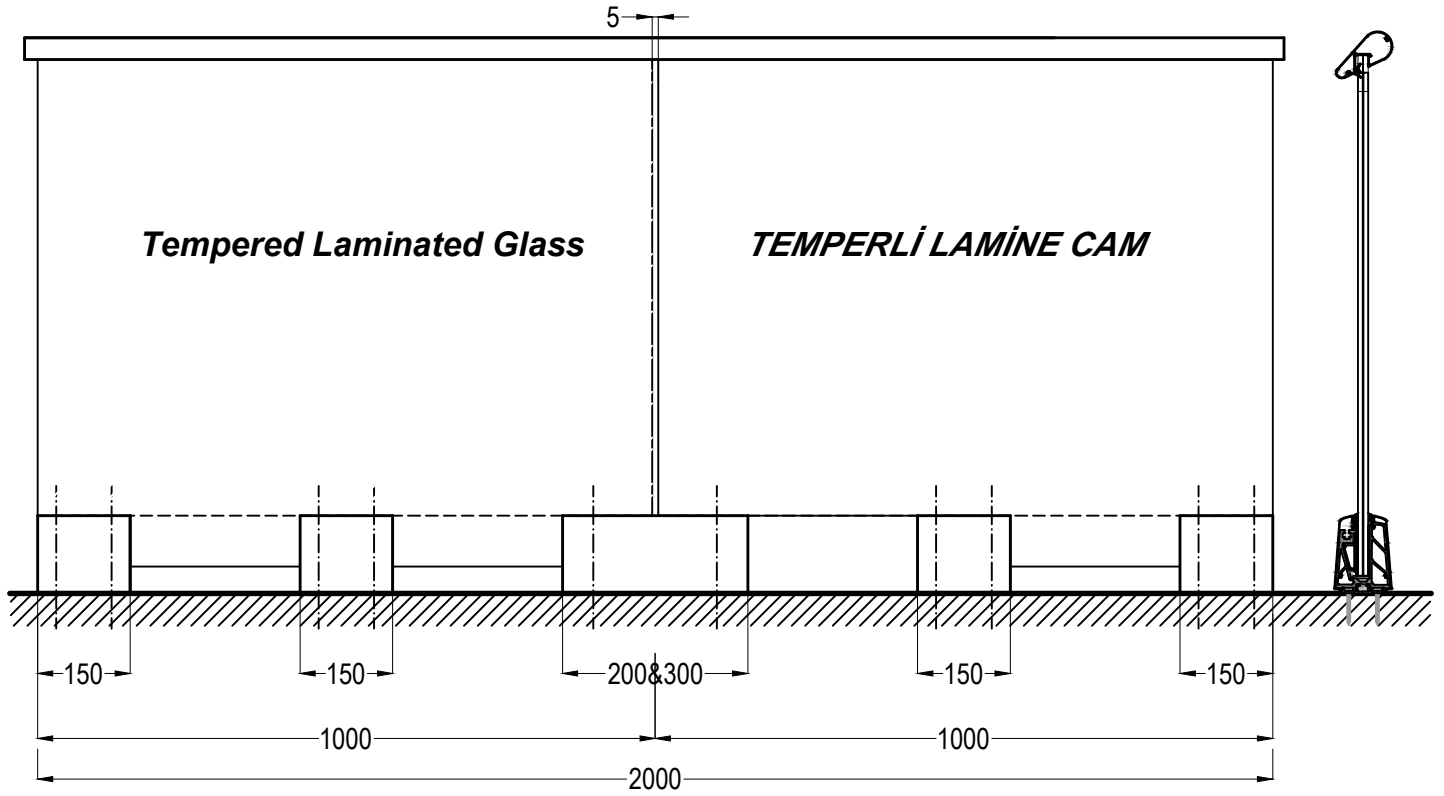

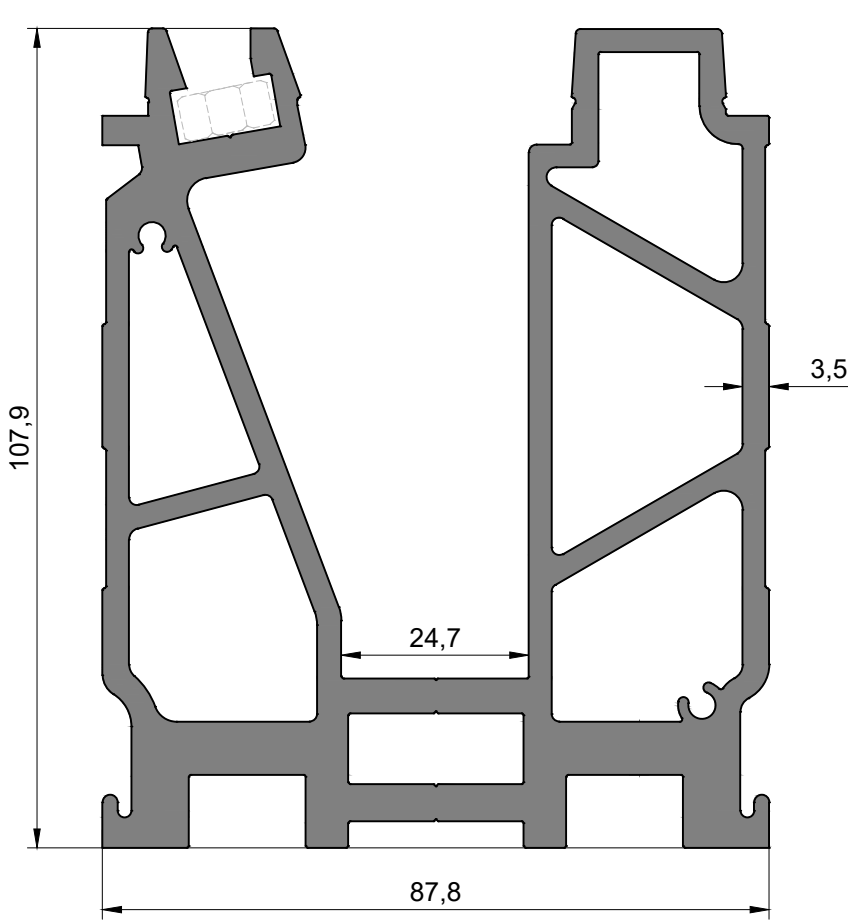

20-2520	
CAM BAZA PROFİLİ GLASS RAILING PROFILE	AĞIRLIK / Weight 6,960 kg/mt

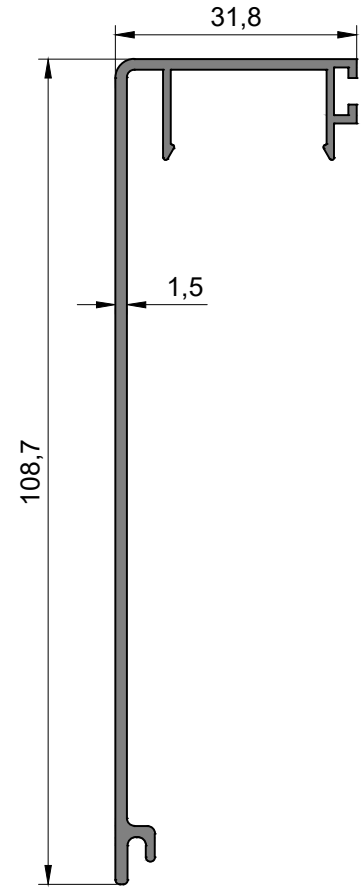



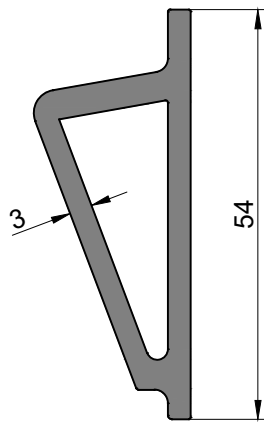



20-2521	
KAPAK PROFİLİ COVER PROFILE	AĞIRLIK / Weight 0,662 kg/mt



20-2522	
CAM SIKIŞTIRMA PRO. GLASS COMPRESSION PROFILE	AĞIRLIK / Weight 0,953 kg/mt

KÜPEŞTE FITİL VE AKSESUARLARI

ÇİZİM/DRAW	KOD/CODE	MALZEME/MAT.	AÇIKLAMA
	EP2-01	EPDM	10+(1,52pvb)+10 İç-Dış Cam kapama Glass
	EP2-02	EPDM	8+(1,52pvb)+8 dış Cam kapama Glass
	KC 06	EPDM	8+(1,52pvb)+8 iç Cam kapama Glass
	CT-001	PVC	PVC 3mm cam Takoðu PVC Wedge
	EM 2520-2	PVC	2mm PVC Takoð PVC Wedge
	EM 2520-1	PVC	1mm PVC Takoð PVC Wedge
	2520-CAP	STELL	KAPAK Cover

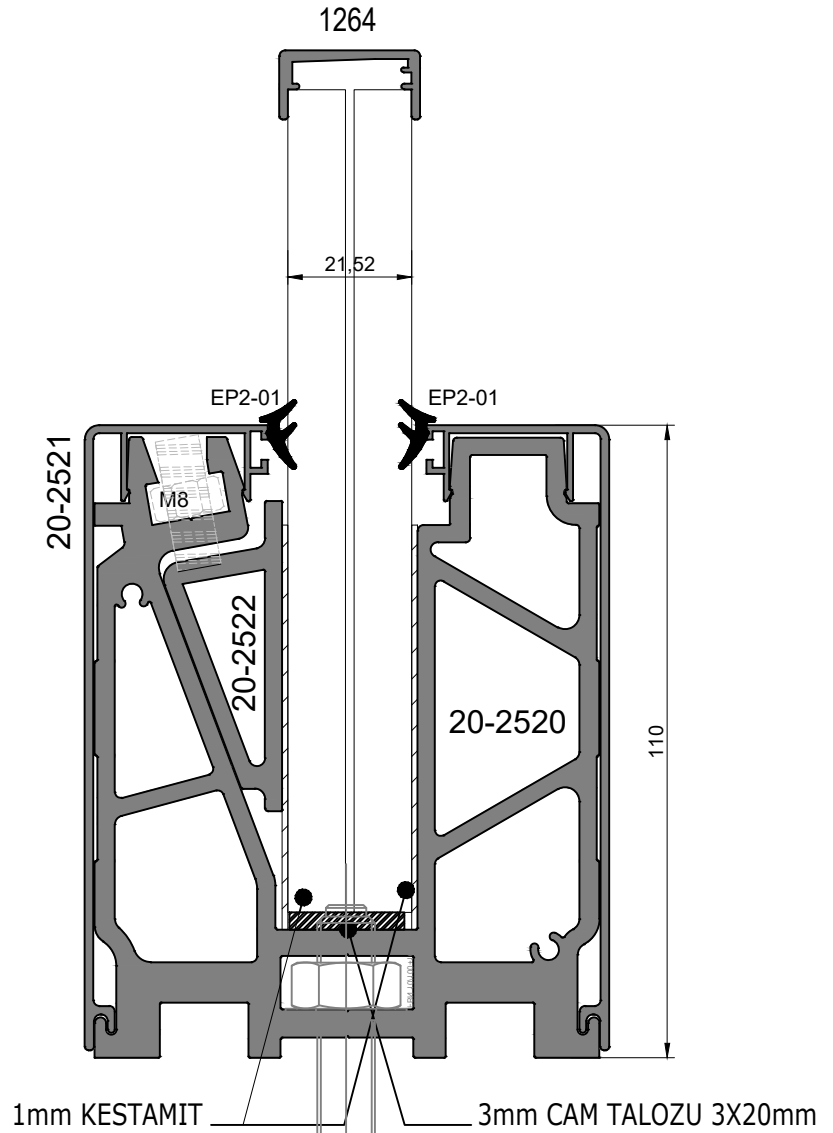
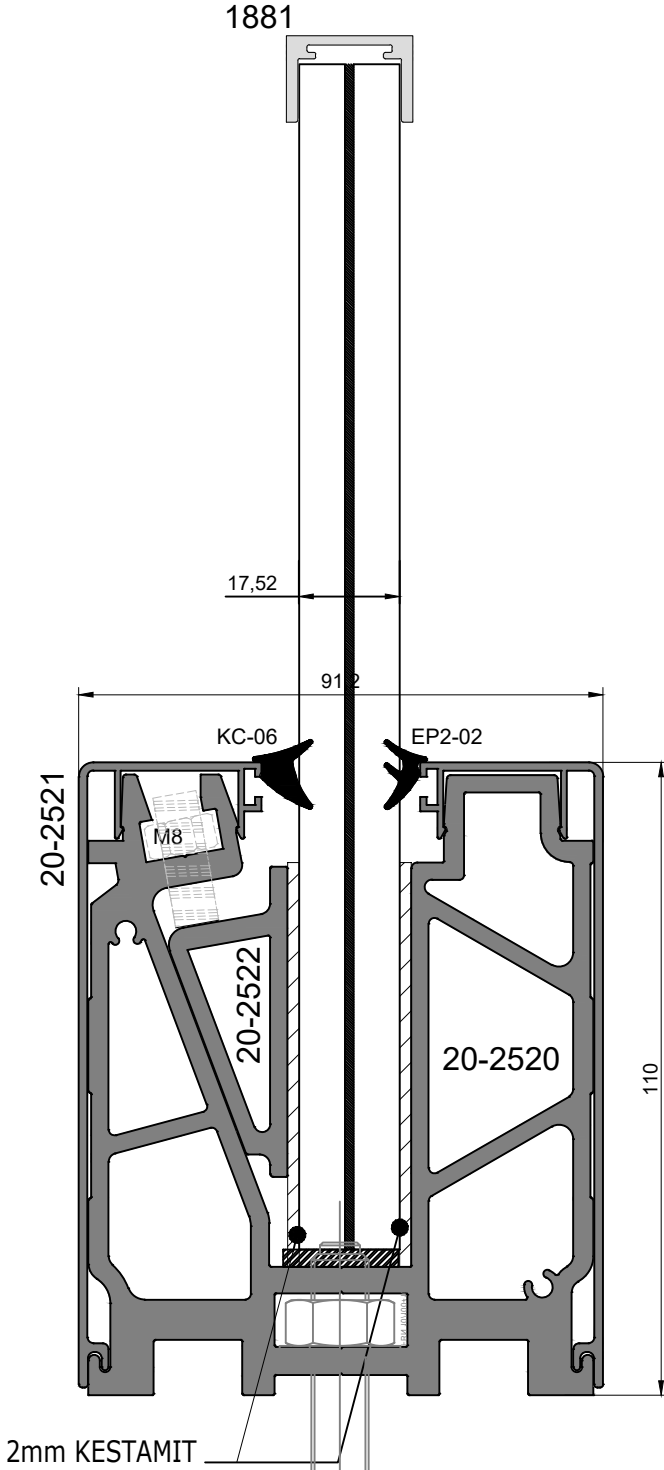

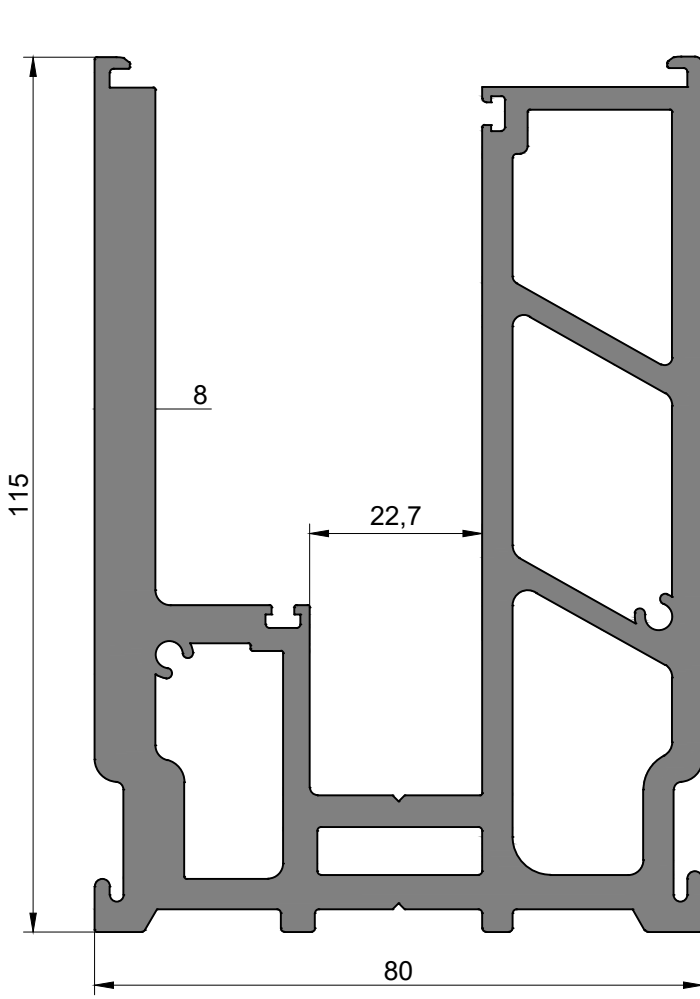

1882	
CAM BAZA PROFİLİ <i>GLASS RAILING PROFILE</i>	AĞIRLIK / Weight
	7,170 kg/mt

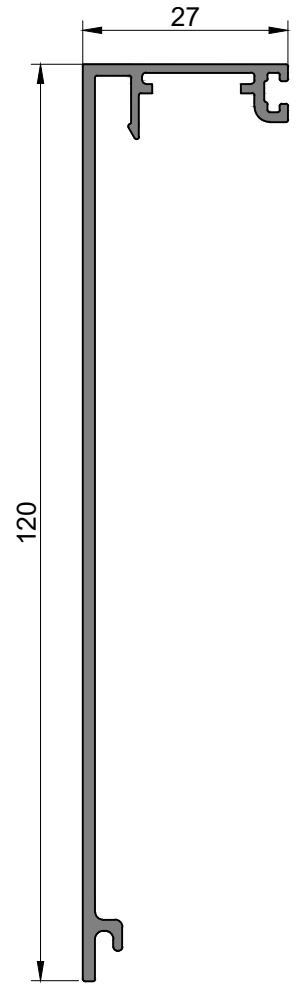

1880	
KAPAK PROFİLİ <i>COVER PROFILE</i>	AĞIRLIK / Weight
	0,707 kg/mt

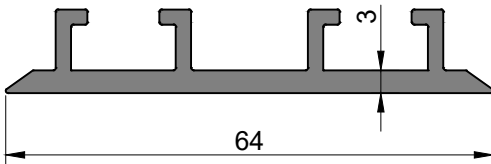

1883	
CAM SIKIŞTIRMA PRO. <i>GLASS COMPRESSION PROFILE</i>	AĞIRLIK / Weight
	0,716 kg/mt

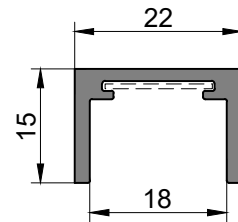



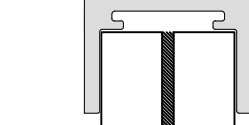

1881	
KÜPEŞTE ÜST PROFİL <i>TOP RAILING PROFILE</i>	AĞIRLIK / Weight
	0,271 kg/mt

1881



17,52

KÜPEŞTE FİTİL VE AKSESUARLARI

ÇİZİM/DRAW	KOD/CODE	AÇIKLAMA
	EP 1882	U CAM FİTİLİ 8+(1,52pvb)+8 Cam Glass
	EP 1880	İç, Dış Cam Kapama Fitili Inner, Outer Gasket
	EP 1883	Cam Sıkıştırma Fitili Press Gasket
	1882-CAP	KAPAK Cover

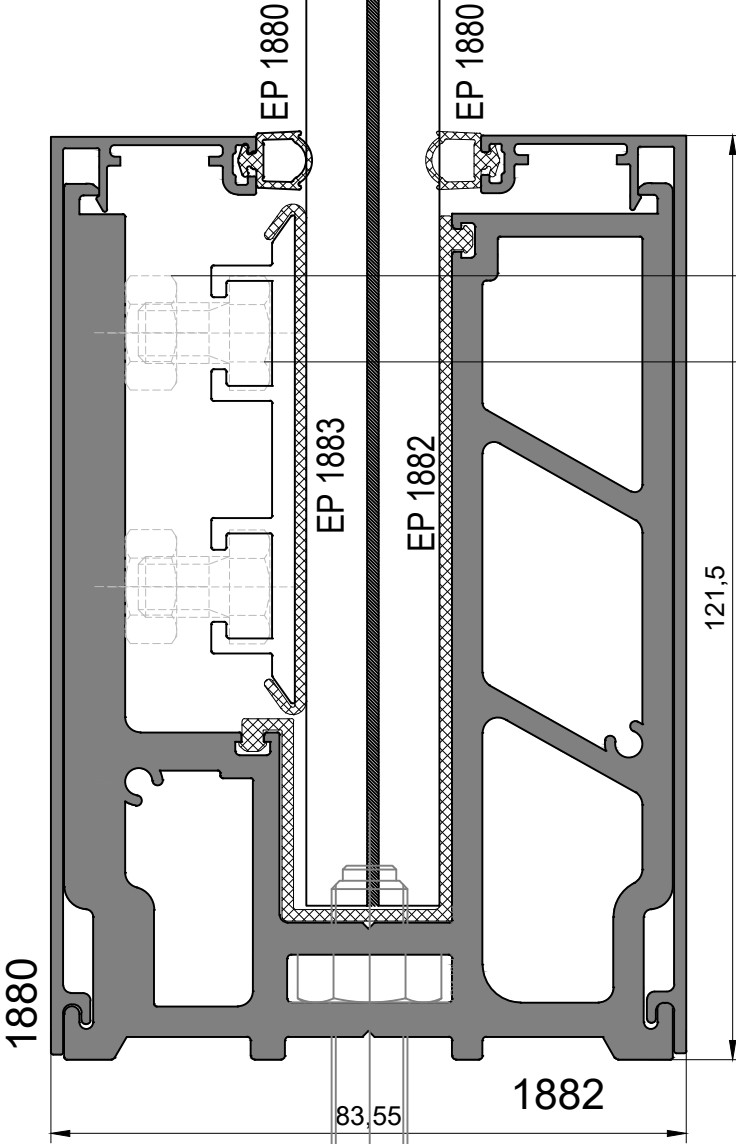

DIN 934 M8x13
Paslanmaz Cıvata

DIN 931 M8x13
Paslanmaz Cıvata

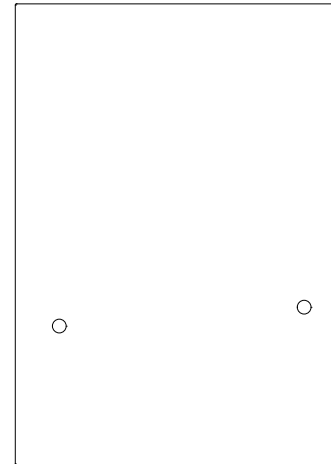

1882 CAP
SC 1/2

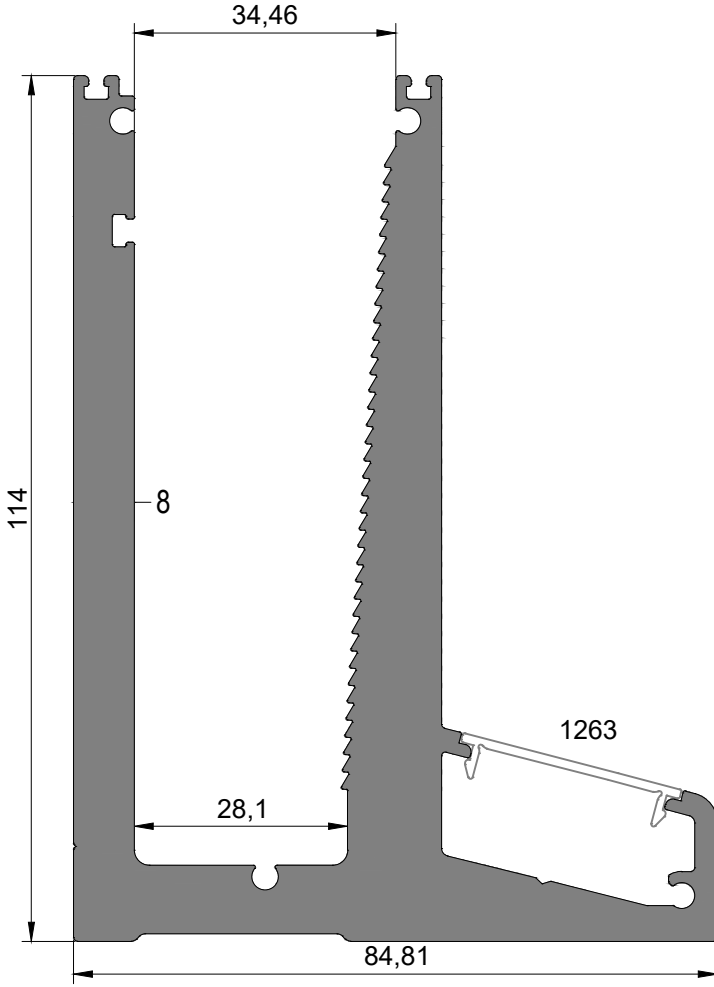

1262	
CAM BAZA PROFİLİ GLASS RAILING PROFILE	AĞIRLIK / Weight 6,959 kg/mt

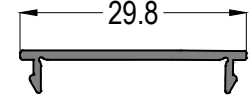

1263	
KAPAK PROFİLİ COVER PROFILE	AĞIRLIK / Weight 0,120 kg/mt

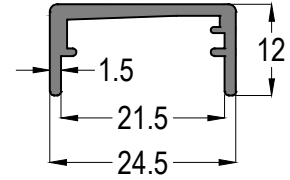

1264	
KÜPEŞTE ÜST PROFİLİ TOP RAILING PROFILE	AĞIRLIK / Weight 0,218 kg/mt

KÜPEŞTE FİTİL VE AKSESUARLARI

ÇİZİM/DRAW	KOD/CODE	MALZEME/MAT.	AÇIKLAMA	KOLİ
	EP2-1262-10	EPDM	10+(1,52pvb)+10 Cam Glass	
	EP2-1262-13	EPDM	8+(1,52pvb)+8 Cam Glass	
	EP2-1262-17	EPDM	İç Cam Kapama Fıtılı Inner Gasket	
	EP1-1262-1	EPDM	8+(1,52pvb)+8 Cam Glass	
	PVC-01	PVC	PVC Takoz PVC Wedge	
	1262-CAP	STELL	KAPAK Cover	

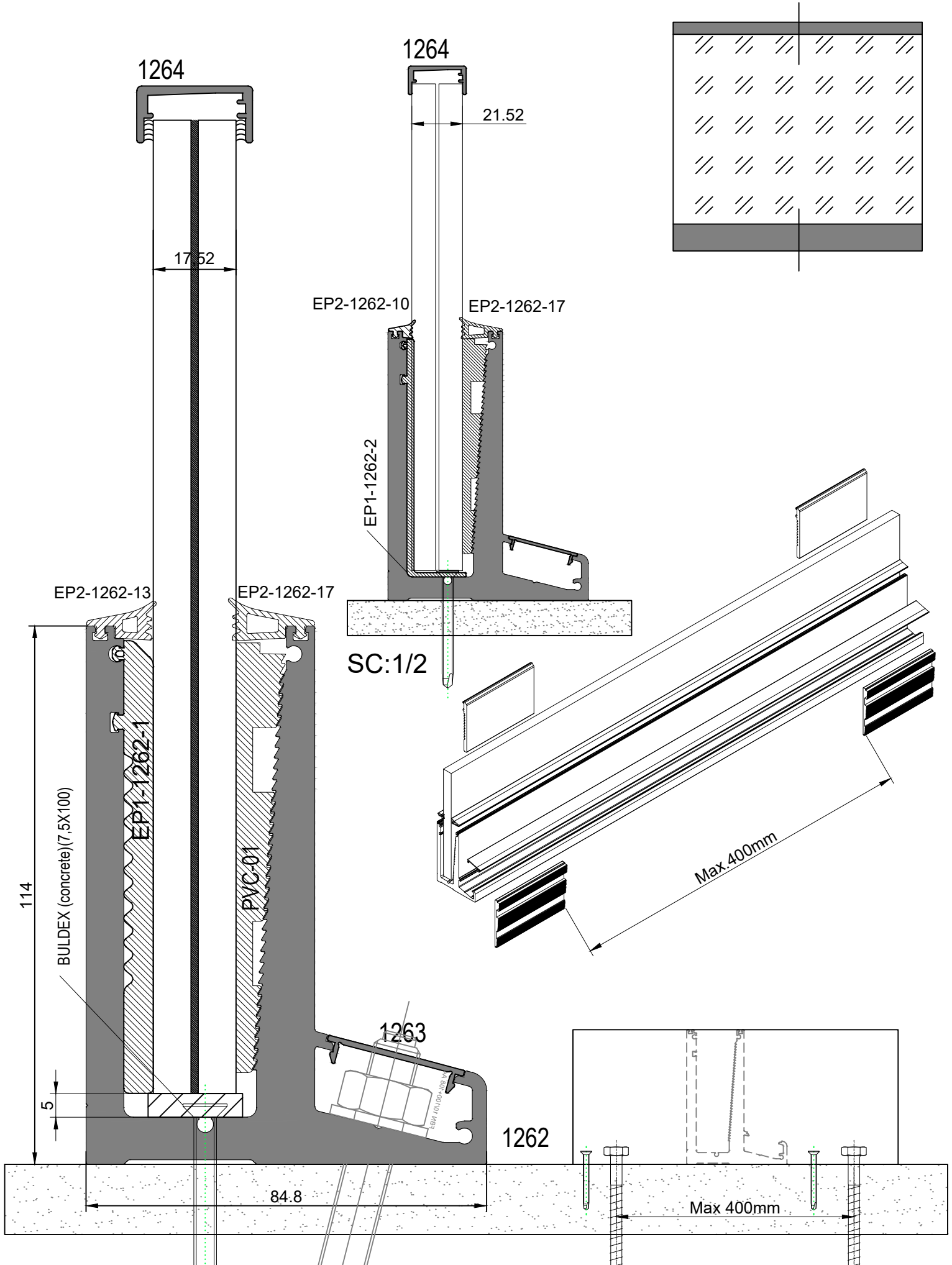

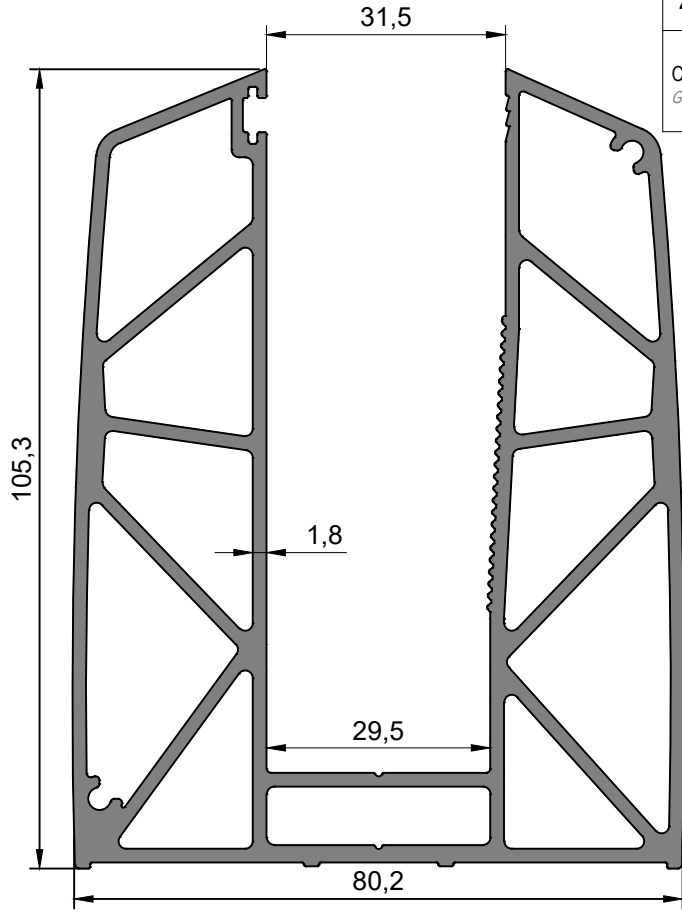

20-2408

CAM BAZA PROFİLİ
GLASS RAILING PROFILE

AĞIRLIK / Weight

4,030 kg/mt

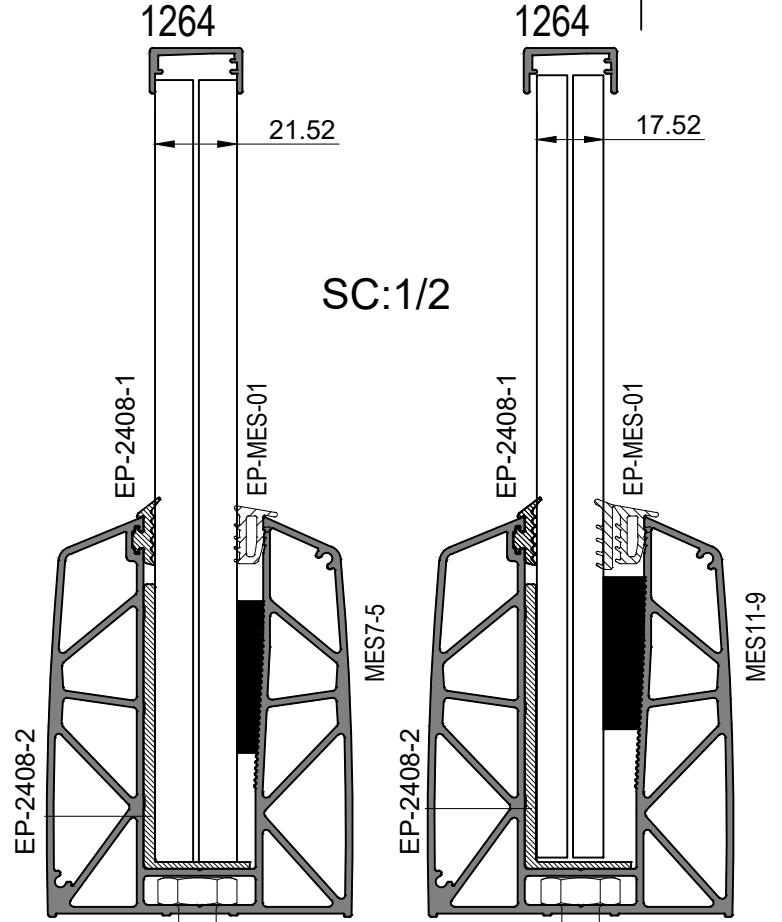
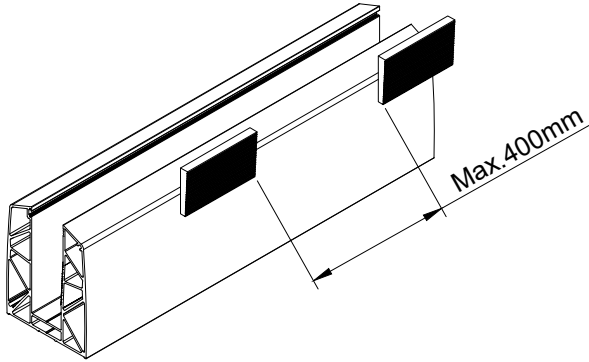
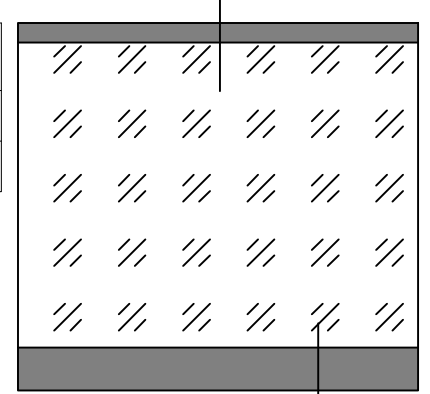

KÜPEŞTE FİTİL VE AKSESUARLARI

ÇİZİM/DRAW	KOD/CODE	MALZEME/MAT.	AÇIKLAMA	KOLİ
	EP-2408-1	EPDM	Dış Cam Fıtlı Out Gasket	
	EP-2408-2	EPDM	8+(1,52pvb)+8 10+(1,52pvb)+10 Cam Glass	
	EP-MES-01	EPDM	İç Cam Kapama Fıtlı Inner Gasket	
	MES7-5	PVC	10+(1,52pvb)+10 Cam Glass	
	MES11-9	PVC	8+(1,52pvb)+8 Cam Glass	
	2408-CAP	STELL	KAPAK Cover	

1630

CAM BAZA PROFİLİ
GLASS RAILING PROFILE

AĞIRLIK / Weight

2,667 kg/mt

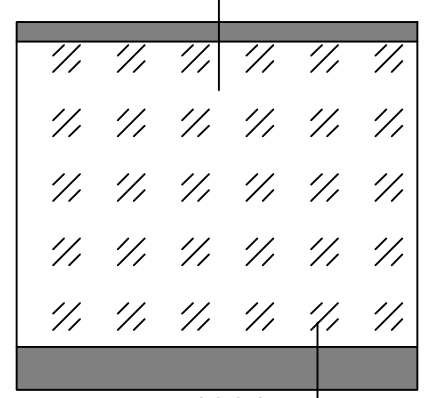
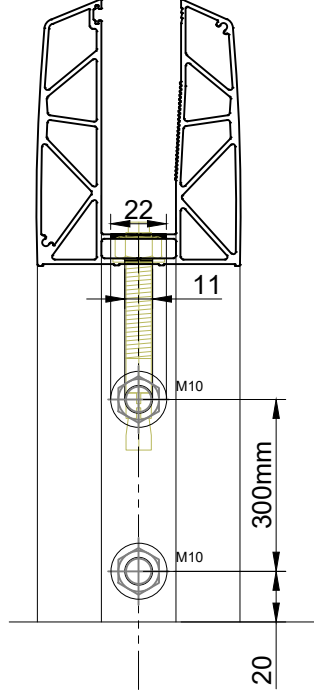
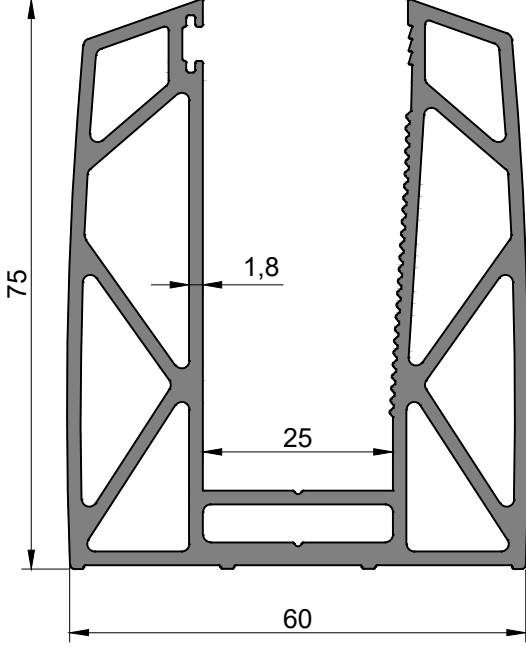

1264

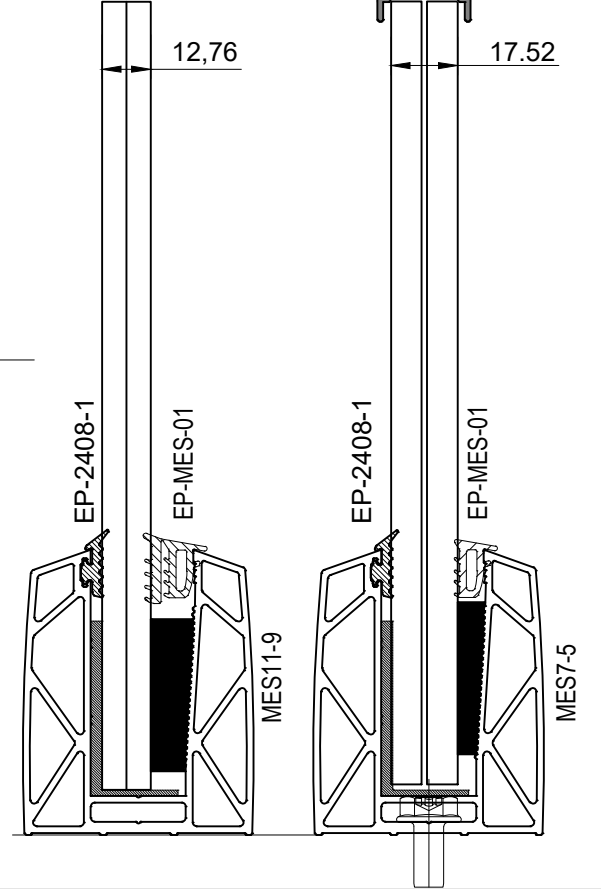
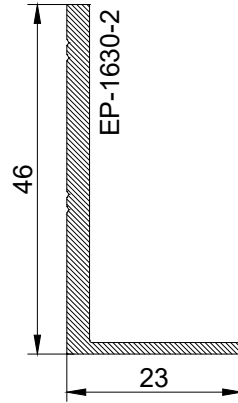
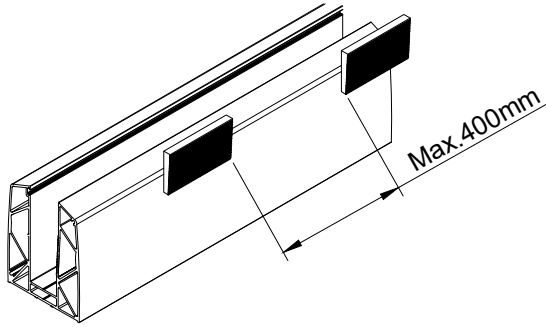

KÜPEŞTE FİTİL VE AKSESUARLARI

ÇİZİM/DRAW	KOD/CODE	MALZEME/MAT.	AÇIKLAMA	KOLİ
	EP-2408-1	EPDM	Dış Cam Fitili Out Gasket	
	EP-1630-2	EPDM	8+(1,52pvb)+8 10+(1,52pvb)+10 Cam Glass	
	EP-MES-01	EPDM	İç Cam Kapama Fitili Inner Gasket	
	MES7-5	PVC	10+(1,52pvb)+10 Cam Glass	
	MES11-9	PVC	6+(0,76pvb)+6 Cam Glass	

PROFİL LİSTESİ - PROFILE LISTS

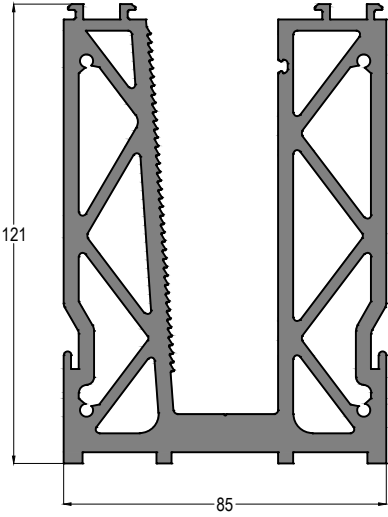
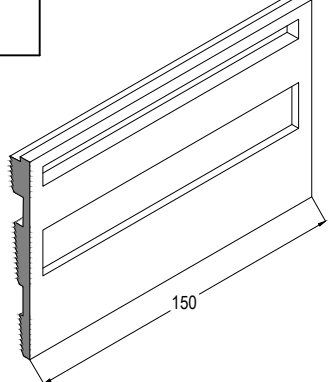
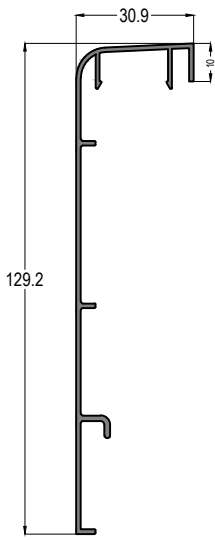
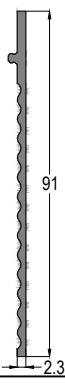
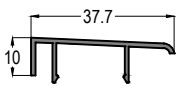
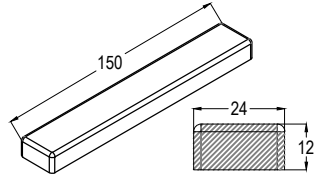
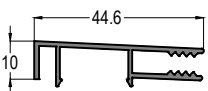
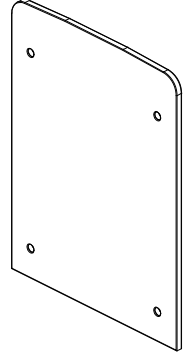
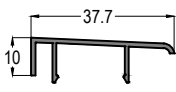
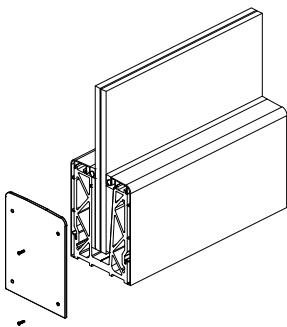
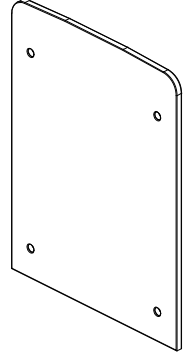
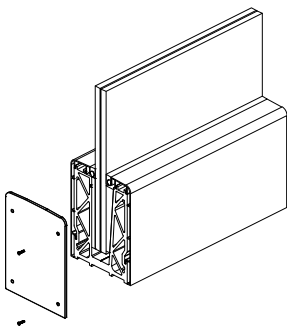
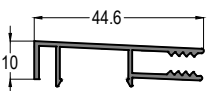
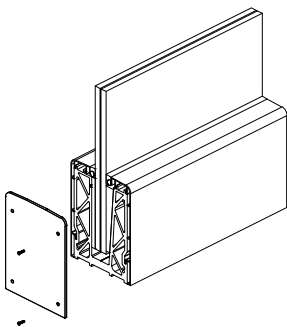
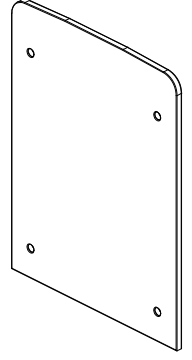
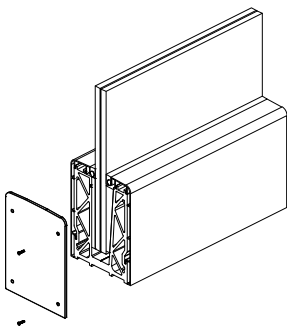
20-2402			PVC-01		
CAM TUTUCU PROFİL GLASS HOLDER PROFILE	AĞIRLIK / Weight 9,241 kg/mt		PVC TAKOZ PVC WEDGE		
20-2510			EP150-01		
KAPAK PROFİLİ COVER PROFILE	AĞIRLIK / Weight 0,670 kg/mt		EPDM FİTİL 10+10 CAM İÇİN EPDM GASKET FOR 10+10 GLASS		
20-2507			PVC-02		
KAPAK PROFİLİ COVER PROFILE	AĞIRLIK / Weight 0,207 kg/mt		PVC TAKOZ PVC WEDGE		
20-2508			KPK-01		
KAPAK PROFİLİ COVER PROFILE	AĞIRLIK / Weight 0,309 kg/mt		KAPAK COVER		
20-2507					
KAPAK PROFİLİ COVER PROFILE	AĞIRLIK / Weight 0,207 kg/mt				
20-2508					
KAPAK PROFİLİ COVER PROFILE	AĞIRLIK / Weight 0,309 kg/mt				



DETAY - DETAIL

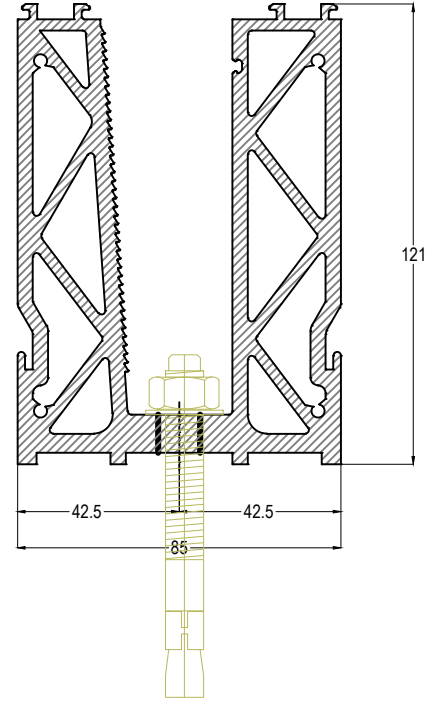
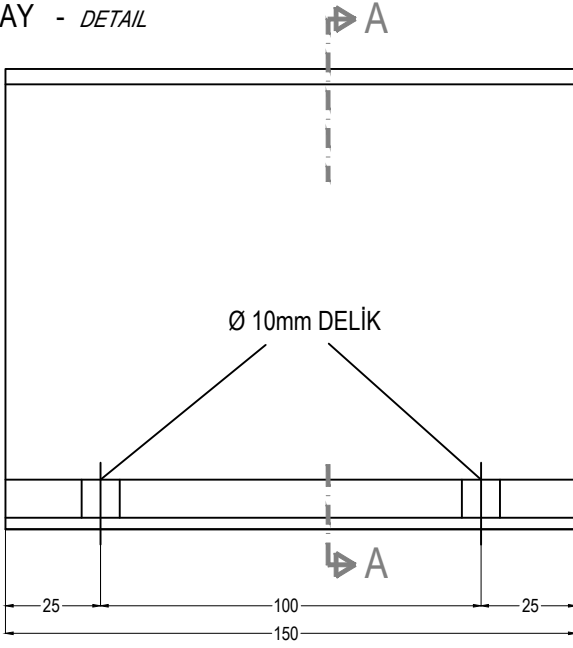

A - A KESİTİ
A - A SECTION

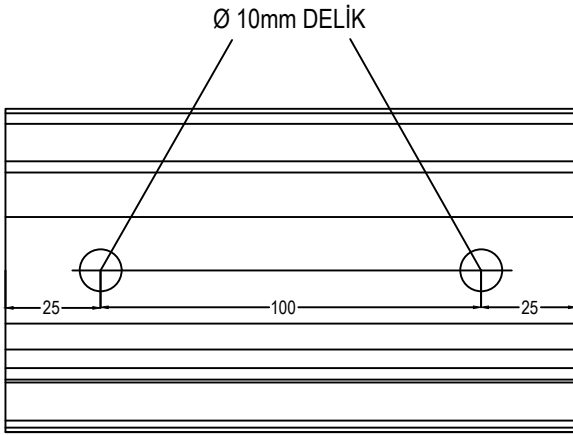

ÜST GÖRÜNÜŞ
TOP ELEVATION

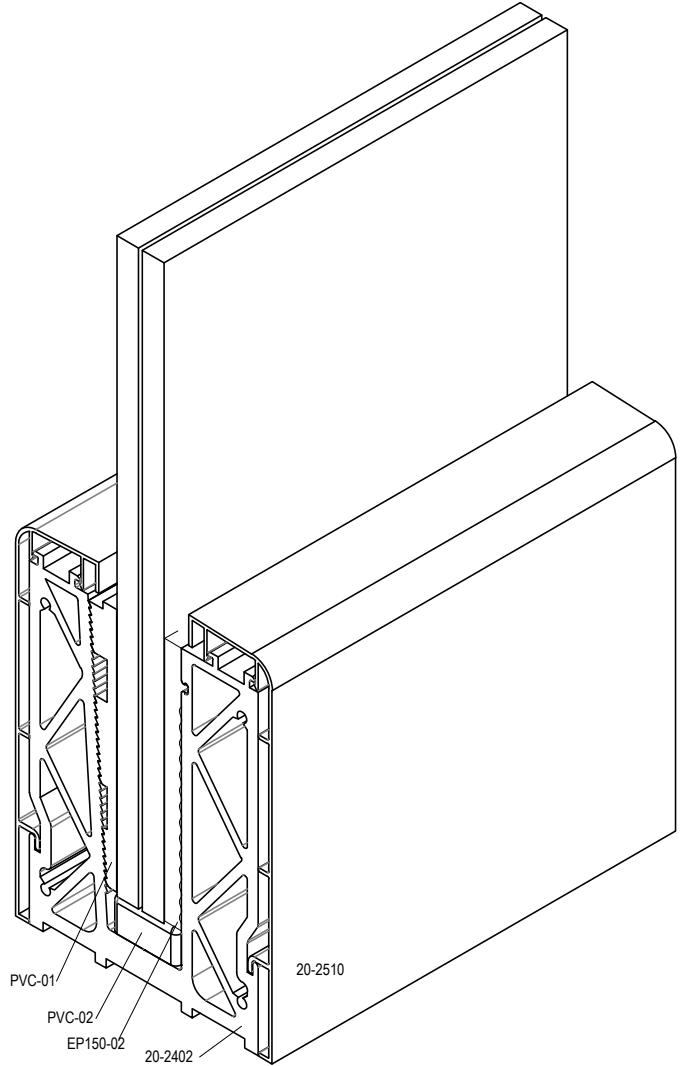



DETAY - DETAIL

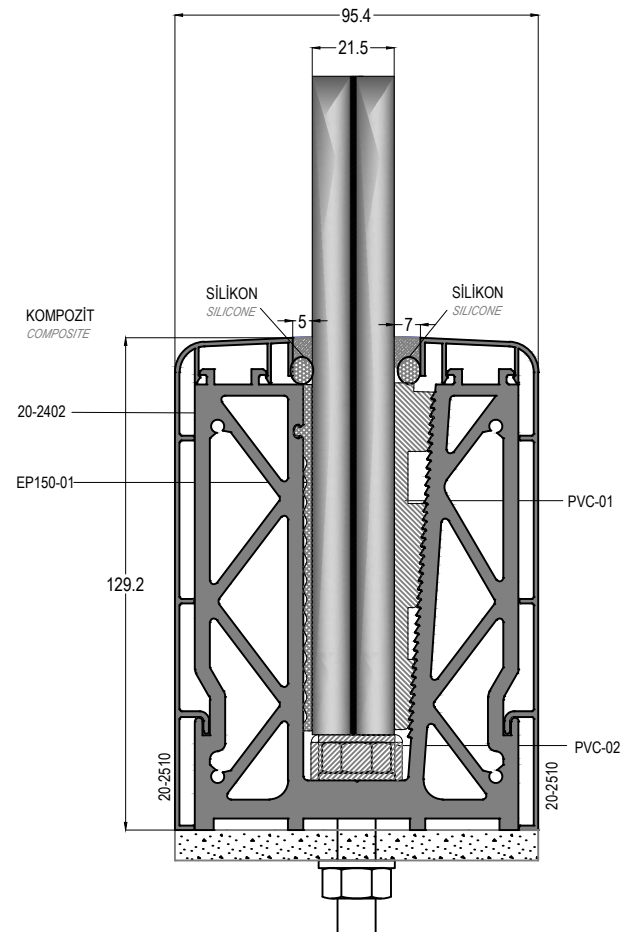
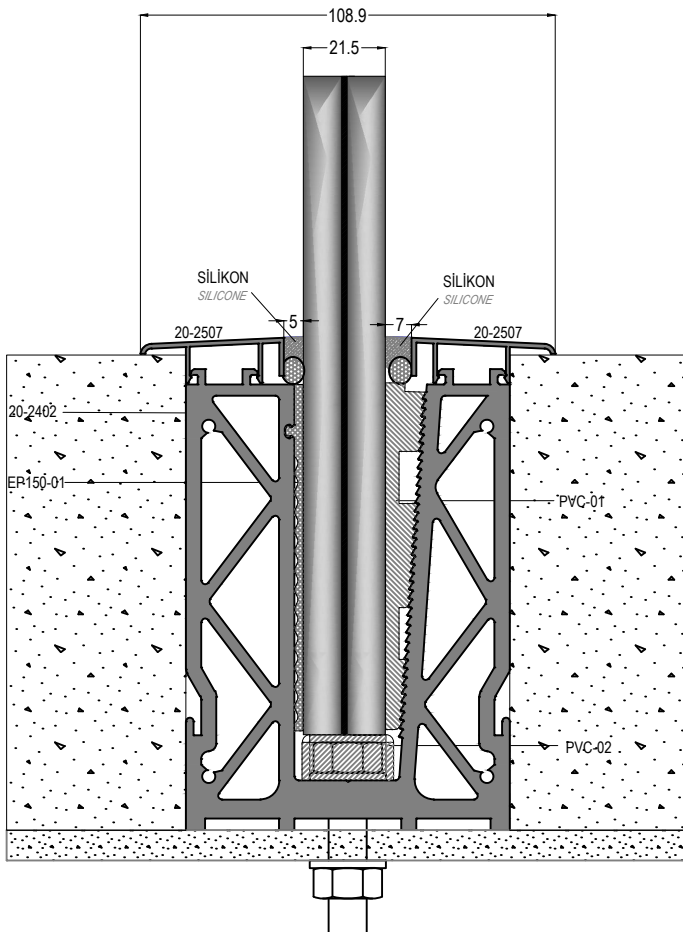
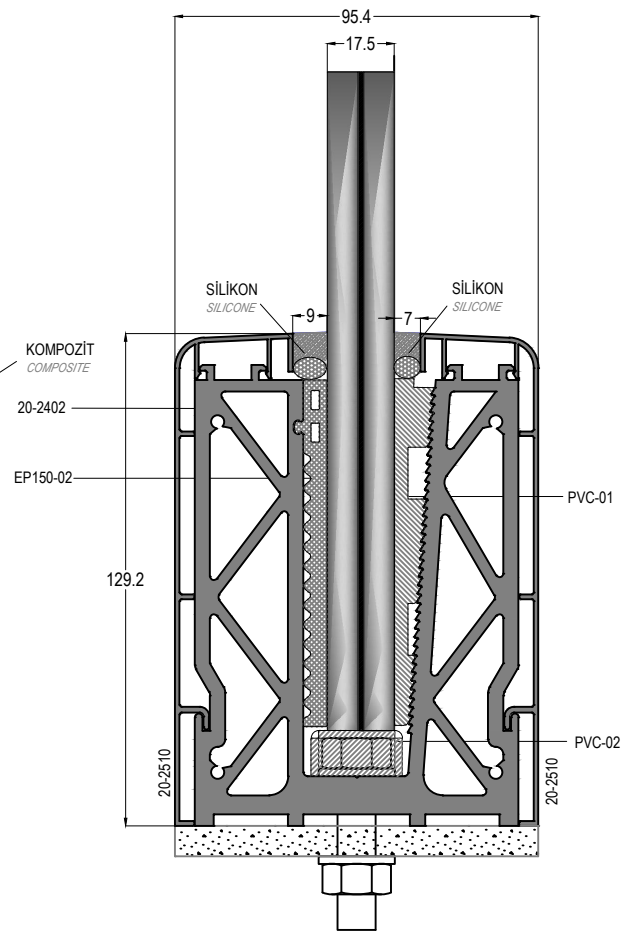
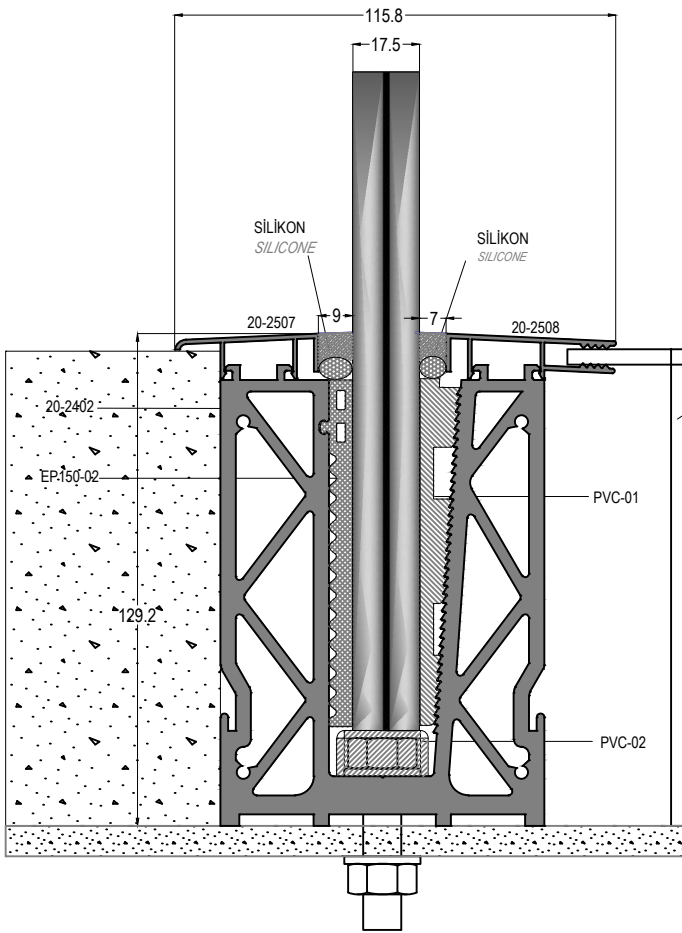

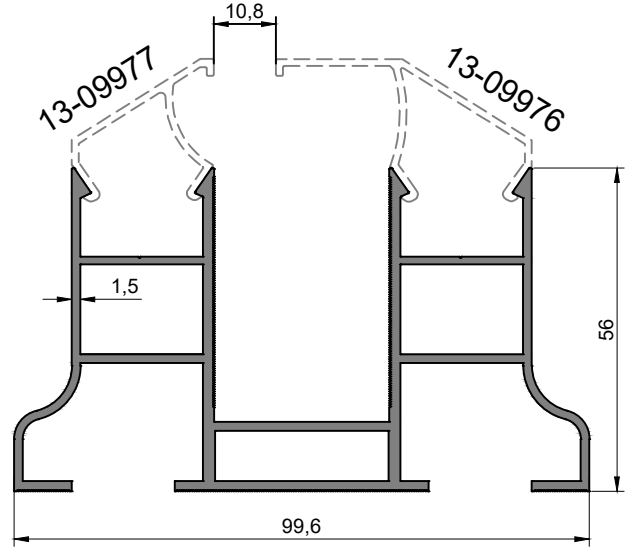
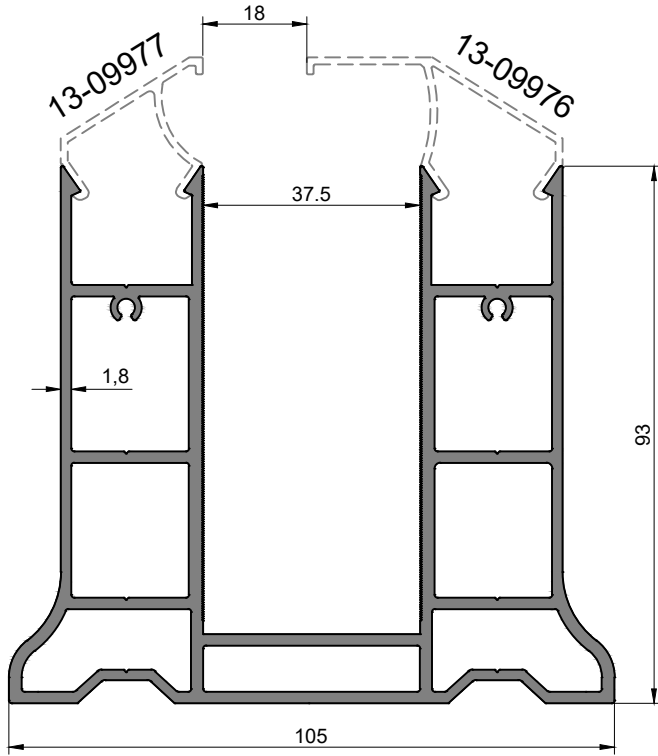

13-09978	
CAM BAZA PROFİLİ GLASS RAILING PROFILE	AĞIRLIK / Weight 3,580 kg/mt

1510	
CAM BAZA PROFİLİ GLASS RAILING PROFILE	AĞIRLIK / Weight 1,795 kg/mt

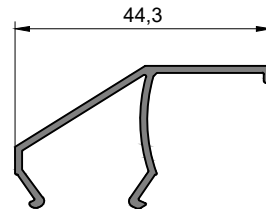
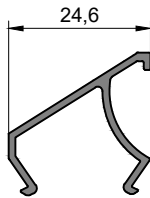

13-09977	
CAM ÇİTASI GLASS BEAD PROFILE	AĞIRLIK / Weight 0,216 kg/mt

13-09976	
CAM ÇİTASI GLASS BEAD PROFILE	AĞIRLIK / Weight 0,290 kg/mt

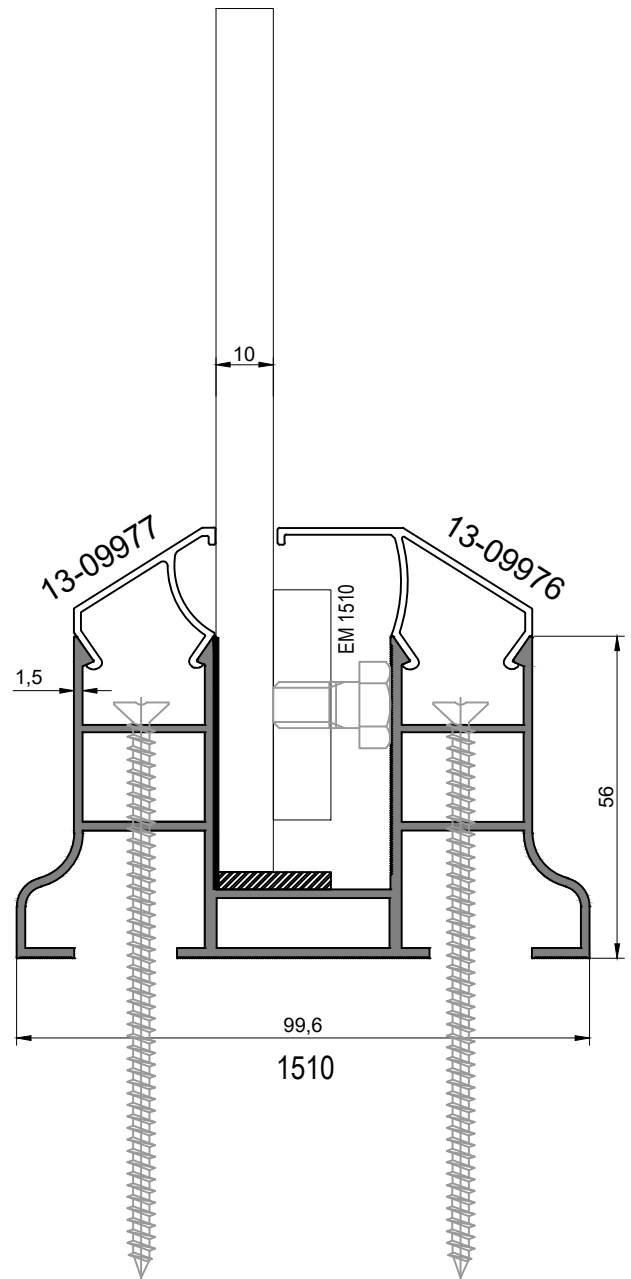
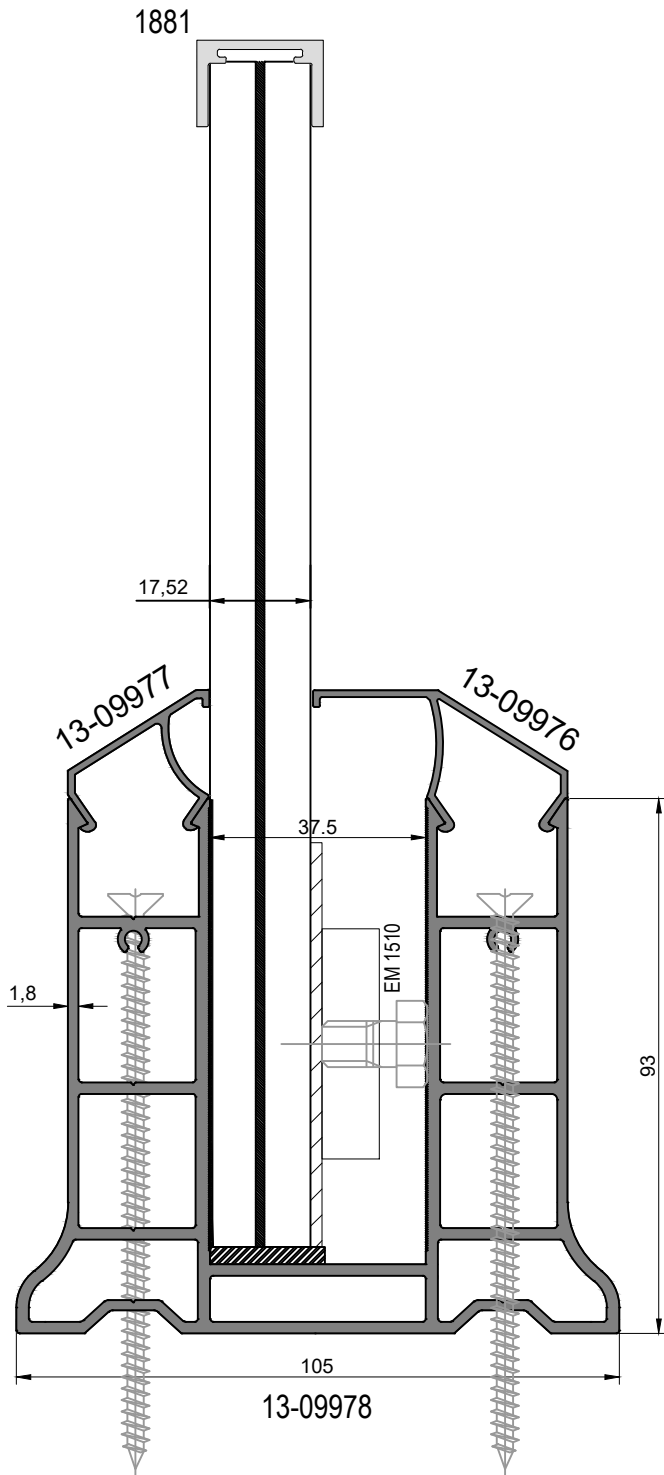



PROFİL LİSTESİ - PROFILE LISTS

<p>20-730141-32</p>			<p>13-09021</p>		
<p>CAM TUTUCU PROFİL GLASS HOLDER PROFILE</p>	<p>AĞIRLIK / Weight 1,917 kg/mt</p>		<p>KÜPEŞTE ÜST PROFİL TOP RAILING PROFILE</p>	<p>AĞIRLIK / Weight 1,661 kg/mt</p>	
<p>20-100141-32</p>			<p>20-109151-22</p>		
<p>CAM TUTUCU PROFİL GLASS HOLDER PROFILE</p>	<p>AĞIRLIK / Weight 2,518 kg/mt</p>		<p>KÜPEŞTE ÜST PROFİL TOP RAILING PROFILE</p>	<p>AĞIRLIK / Weight 1,851 kg/mt</p>	
<p>20-730042-20</p>			<p>20-154021-20</p>		
<p>CAM TUTUCU PROFİL GLASS HOLDER PROFILE</p>	<p>AĞIRLIK / Weight 1,285 kg/mt</p>		<p>KÜPEŞTE ÜST PROFİL TOP RAILING PROFILE</p>	<p>AĞIRLIK / Weight 2,615 kg/mt</p>	
<p>20-120171-38</p>					
<p>CAM TUTUCU PROFİL GLASS HOLDER PROFILE</p>	<p>AĞIRLIK / Weight 5,273 kg/mt</p>				