

LS60

YALITIMLI SÜRME SİSTEMİ
THERMAL SLIDING SYSTEM

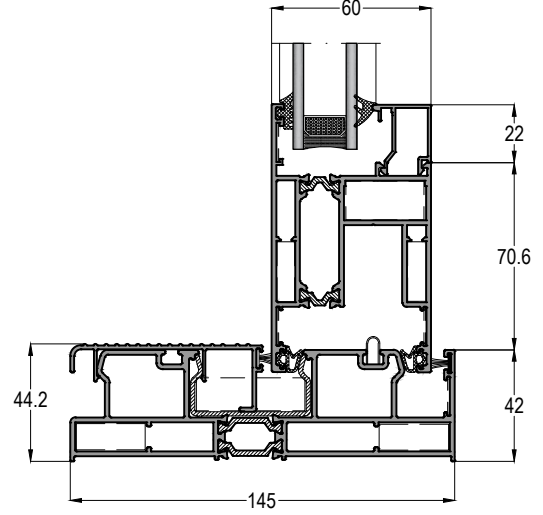

KASA GENİŞLİĞİ Frame Width	: 136mm - 145mm - 221mm
KANAT DERİNLİĞİ Sash Depth	: 60mm
SİSTEM ET KALINLIĞI System Wall Thickness	: 1,4 mm - 1,8 mm
ISI BARIYERİ Insulation Barrier	: Kasa 24mm - Kanat 14,8mm
CAM KALINLIĞI Glass Thickness	: 10mm - 46mm
KANAT TAŞIMA KAPASİTESİ Sash Carrying Capacity	: 300kg - 400kg
MAX. KANAT ENİ Max. Sash Width	: 720mm - 3235mm
MAX. KANAT YÜKSEKLİĞİ Max. Sash Height	: 1200mm - 2700mm

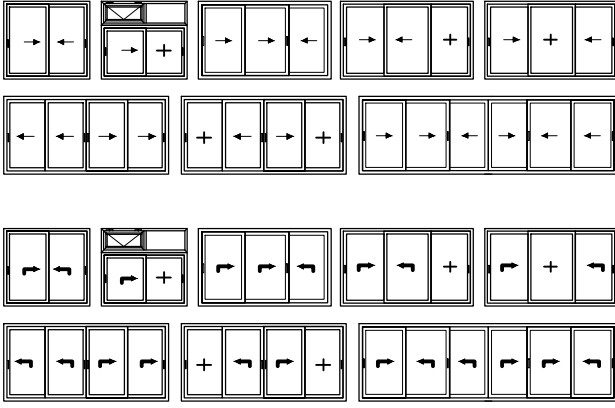
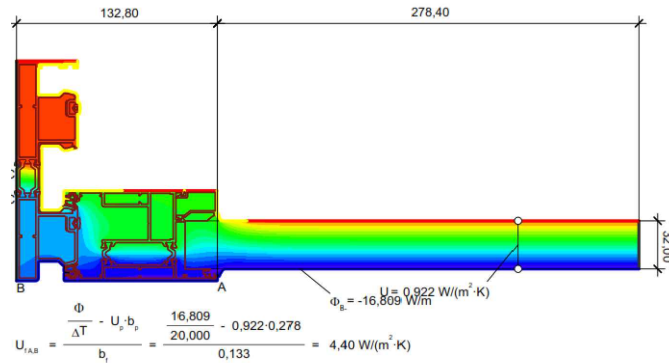

LS60 - 1,8mm

YALITIMLI KALDIR-SÜR SİSTEMİ
THERMAL LIFT&SLIDE SYSTEM







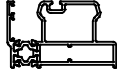
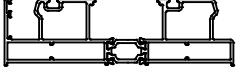
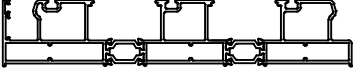
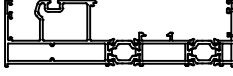
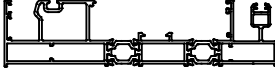
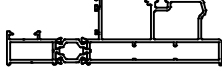
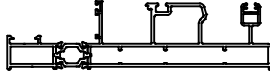
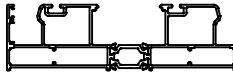
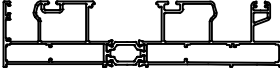
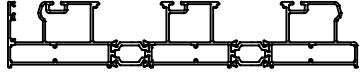
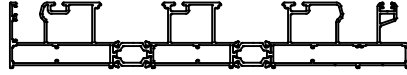



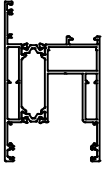
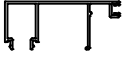
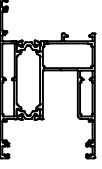

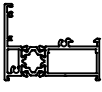
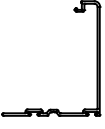
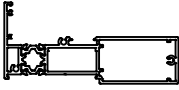
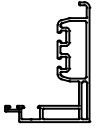
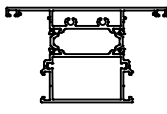

ASISTAL

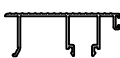
PROFİL VE AKSESUAR LİSTELERİ
PROFILE & ACCESSORIES LIST



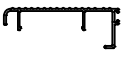







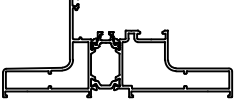

PROFİL LİSTESİ - PROFILES LIST

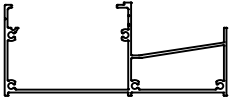
LS60 01			LS60 02		
KASA PROFİLİ FRAME PROFILE	AĞIRLIK / Weight 1,591 kg/mt		KASA PROFİLİ FRAME PROFILE	AĞIRLIK / Weight 2,822 kg/mt	
LS60 03					
3 LÜ KASA PROFİLİ FRAME PROFILE	AĞIRLIK / Weight 4,210 kg/mt				
LS60 04			NOT: LS60 04 KASA, CAM KALINLIĞI 24mm DEN FAZLA OLAN CAMLARIN MONTAJI İÇİN UYGUN DEĞİLDİR LS60 04 CASE, NOT SUITABLE FOR INSTALLATION FOR GLASSES WITH GLASS THICKNESS MORE THAN 24mm		
DIŞTAN SABİTLİ KASA PROFİLİ MONORAIL FRAME PROFILE	AĞIRLIK / Weight 2,764 kg/mt				
LS60 104			NOT: LS60 104 KASA, CAM KALINLIĞI 24mm DEN FAZLA OLAN CAMLARIN MONTAJI İÇİN UYGUN DEĞİLDİR LS60 104 CASE, NOT SUITABLE FOR INSTALLATION FOR GLASSES WITH GLASS THICKNESS MORE THAN 24mm		
DIŞTAN SABİTLİ SİNEKLİK KASA PROFİLİ MONORAIL FRAME PROFILE	AĞIRLIK / Weight 3,223 kg/mt				
LS60 118					
İÇTEN SABİTLİ KASA PROFİLİ MONORAIL FRAME PROFILE	AĞIRLIK / Weight 2,345 kg/mt				
LS60 119					
İÇTEN SABİT SİNEKLİKLİ KASA PROFİLİ MONORAIL FRAME PROFILE	AĞIRLIK / Weight 2,895 kg/mt				
LS60 05 - 1,4mm					
KASA PROFİLİ-1,4mm FRAME PROFILE	AĞIRLIK / Weight 2,448 kg/mt				
LS60 05F - 1,4mm					
SİNEKLİKLİ KASA PROFİLİ-1,4mm FLY SCREEN FRAME PROFILE	AĞIRLIK / Weight 2,952 kg/mt				
LS60 09 - 1,4mm					
KASA PROFİLİ-1,4mm FRAME PROFILE	AĞIRLIK / Weight 3,698 kg/mt				
LS60 09F - 1,4mm					
KASA PROFİLİ-1,4mm FRAME PROFILE	AĞIRLIK / Weight 4,202 kg/mt				

















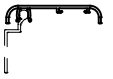

PROFİL LİSTESİ - PROFILES LIST

LS60 11	Jx cm ⁴ 43,22	Jy cm ⁴ 49,37		LS60-40	
KANAT PROFİLİ SASH PROFILE	AĞIRLIK / Weight 2,312 kg/mt			KAPAK PROFİLİ COVER PROFILE	
LS60 12- 1,4mm	Jx cm ⁴ 36,03	Jy cm ⁴ 47,29		LS60 41	
KANAT PROFİLİ-1,4mm SASH PROFILE	AĞIRLIK / Weight 2,080 kg/mt			ADAPTÖR PROFİLİ ADAPTER PROFILE	
LS60 112	Jx cm ⁴ 19,15	Jy cm ⁴ 5,20		LS60 42	
DAR KANAT PROFİLİ SASH PROFILE	AĞIRLIK / Weight 1,244 kg/mt			KENET PROFİLİ CENTRAL LOCKING PROFILE	
LS60 113	Jx cm ⁴ 99,15	Jy cm ⁴ 9,16		LS60 43	
DAR KANAT PROFİLİ SASH PROFILE	AĞIRLIK / Weight 1,933 kg/mt			3'LÜ KANAT ADAPTÖR PROFİLİ ADAPTER PROFILE	
TH60 23				LS60 44	
ORTA KAYIT PROFİLİ TRANSOM-MULLION PROFILE	AĞIRLIK / Weight 2,128 kg/mt			İSPANYOLET KİLİTLEME ADAPTÖR PROFİLİ MULTI POINT LOCK ADAPTER	
LS60 31				LS60 45	
KAPAK PROFİLİ COVER PROFILE	AĞIRLIK / Weight 0,686 kg/mt			KENET PROFİLİ CENTRAL LOCKING PROFILE	
LS60 32				LS60 46	
DEKORATİF KAPAK PROFİLİ DECORATIVE COVER PROFILE	AĞIRLIK / Weight 0,710 kg/mt			YAN KAPAK PROFİLİ SIDE COVER PROFILE	
LS60 33				LS60 71	
KAPAK PROFİLİ COVER PROFILE	AĞIRLIK / Weight 0,523 kg/mt			KULP PROFİLİ HANDLE PROFILE	
LS60 34				LS60 72	
DEKORATİF KAPAK PROFİLİ DECORATIVE COVER PROFILE	AĞIRLIK / Weight 0,545 kg/mt			KULP KAPAK PROFİLİ HANDLE COVER PROFILE	
LS60 35				12-71	
KANAT SABİTLEME PROFİLİ SASH FIXING PROFILE	AĞIRLIK / Weight 0,670 kg/mt			ADAPTÖR PROFİLİ ADAPTER PROFILE	



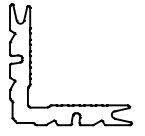

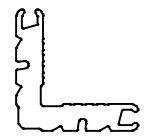

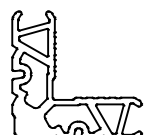









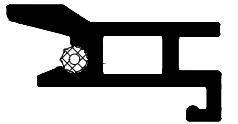

PROFİL LİSTESİ - PROFILES LIST

12-72			1042		
ADAPTÖR PROFİLİ ADAPTER PROFILE	AĞIRLIK / Weight 0,285 kg/mt		SİNEKLİK RAY PROFİLİ FLYSCREEN RAIL PROFILE	AĞIRLIK / Weight 0,553 kg/mt	
LS60 62			SL-1515		
TH62 SİSTEM GEÇİŞ KASA PROFİLİ FRAME PROFILE FOR TH62	AĞIRLIK / Weight 2,418 kg/mt		KASA MONTAJ PROFİLİ FRAME ASSEMBLY PROFILE	AĞIRLIK / Weight 0,092 kg/mt	
DR-001					
DRENAJ KANAL PROFİLİ WATER DRAINAGE PROFILE	AĞIRLIK / Weight 1,998 kg/mt				
DR-002					
DRENAJ KANAL UZATMA PROFİLİ WATER DRAINAGE ADDITIONAL PROFILE	AĞIRLIK / Weight 0,918 kg/mt		MEKANİK İŞLEMLE DELME YAPILMIŞTIR DRILLING WAS DONE BY MECHANICAL PROCESS		
DR-003					
DRENAJ KANAL KAPAK PROFİLİ WATER DRAINAGE COVER PROFILE	AĞIRLIK / Weight 0,724 kg/mt		MEKANİK İŞLEMLE DELME YAPILMIŞTIR DRILLING WAS DONE BY MECHANICAL PROCESS		
LS60 61					
SİNEKLİK RAY PROFİLİ FLYSCREEN RAIL PROFILE	AĞIRLIK / Weight 0,391 kg/mt				
15-304216-09					
SİNEKLİK KANAT PROFİLİ FLYSCREEN SASH PROFILE	AĞIRLIK / Weight 0,352 kg/mt				
15-306317-11					
SİNEKLİK KANAT PROFİLİ FLYSCREEN SASH PROFILE	AĞIRLIK / Weight 0,561 kg/mt				
13-09986					
SİNEKLİK RAY PROFİLİ FLYSCREEN RAIL PROFILE	AĞIRLIK / Weight 0,740 kg/mt				
SL34T-52					
DAR SİNEKLİK KANAT PROFİLİ FLYSCREEN SASH PROFILE	AĞIRLIK / Weight 0,469 kg/mt				





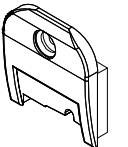

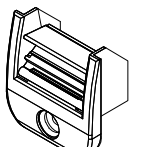

PROFİL LİSTESİ - PROFILES LIST

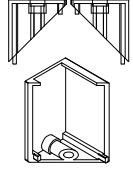
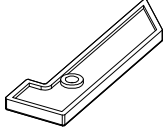
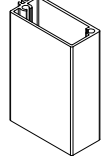
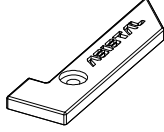
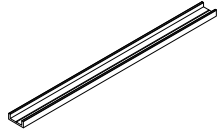
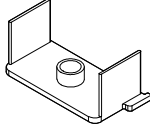
11-004			11-032		
CAM ÇITASI-4 mm GLAZING BEAD PROFILE	AĞIRLIK / Weight 0,181 kg/mt		CAM ÇITASI-32 mm GLAZING BEAD PROFILE	AĞIRLIK / Weight 0,315 kg/mt	
11-106			11-035		
CAM ÇITASI-6 mm GLAZING BEAD PROFILE	AĞIRLIK / Weight 0,200 kg/mt		CAM ÇITASI-35 mm GLAZING BEAD PROFILE	AĞIRLIK / Weight 0,323 kg/mt	
11-010			11-038		
CAM ÇITASI-10 mm GLAZING BEAD PROFILE	AĞIRLIK / Weight 0,233 kg/mt		CAM ÇITASI-38 mm GLAZING BEAD PROFILE	AĞIRLIK / Weight 0,334 kg/mt	
11-015			12-52		
CAM ÇITASI-15 mm GLAZING BEAD PROFILE	AĞIRLIK / Weight 0,244 kg/mt		PERVAZ PROFİLİ BORDER PROFILE	AĞIRLIK / Weight 0,279 kg/mt	
11-017			12-53		
CAM ÇITASI-17 mm GLAZING BEAD PROFILE	AĞIRLIK / Weight 0,250 kg/mt		PERVAZ MONTAJ PROFİLİ BORDER FIXING PROFILE	AĞIRLIK / Weight 0,177 kg/mt	
11-020			12-54		
CAM ÇITASI-20 mm GLAZING BEAD PROFILE	AĞIRLIK / Weight 0,276 kg/mt		PERVAZ PROFİLİ BORDER PROFILE	AĞIRLIK / Weight 0,326 kg/mt	
11-022			12-57		
CAM ÇITASI-22 mm GLAZING BEAD PROFILE	AĞIRLIK / Weight 0,282 kg/mt		PERVAZ PROFİLİ BORDER PROFILE	AĞIRLIK / Weight 0,358 kg/mt	
11-026			10-010106-00		
CAM ÇITASI-26 mm GLAZING BEAD PROFILE	AĞIRLIK / Weight 0,296 kg/mt		KÖŞE TAKOZU-10,6 mm CORNER JOINT	AĞIRLIK / Weight 2,653 kg/mt	
11-028			10-010140-00		
CAM ÇITASI-28 mm GLAZING BEAD PROFILE	AĞIRLIK / Weight 0,302 kg/mt		KÖŞE TAKOZU-14,2 mm CORNER JOINT	AĞIRLIK / Weight 3,582 kg/mt	
11-030			10-010225-00		
CAM ÇITASI-30 mm GLAZING BEAD PROFILE	AĞIRLIK / Weight 0,308 kg/mt		KÖŞE TAKOZU-22,5 mm CORNER JOINT	AĞIRLIK / Weight 3,566 kg/mt	

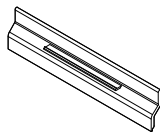
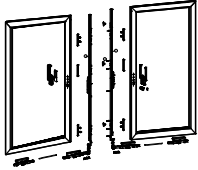
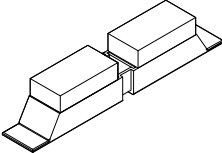
AKSESUAR LİSTESİ - ACCESSORIES LIST

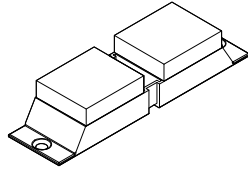
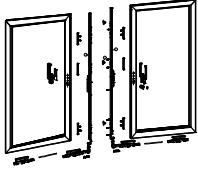
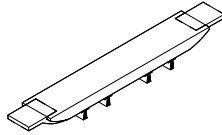
EP1-01			EP5-01		
DİŞ CAM FİTİLİ - 3,5 mm <i>OUTER GLAZING GASKET</i>	KOLİ MİKTARI/Package 240 mt / 15 kg		KANAL FİTİLİ <i>ADAPTER GASKET</i>	KOLİ MİKTARI/Package mt / koli	
EP2-01			KF 67-600		
İÇ CAM FİTİLİ - 3 mm <i>INNER GLAZING GASKET</i>	KOLİ MİKTARI/Package 440 mt / 15 kg		FİRÇA FİTİL-6mm <i>BRUSH GASKET</i>	KOLİ MİKTARI/Package 1300 mt / koli	
EP2-02			KF 67-700		
İÇ CAM FİTİLİ - 4 mm <i>INNER GLAZING GASKET</i>	KOLİ MİKTARI/Package 300 mt / 15 kg		FİRÇA FİTİL-7mm <i>BRUSH GASKET</i>	KOLİ MİKTARI/Package 1100 mt / koli	
EP2-03			KF 67-1000		
İÇ CAM FİTİLİ - 5 mm <i>INNER GLAZING GASKET</i>	KOLİ MİKTARI/Package 250 mt / 15 kg		FİRÇA FİTİL-10mm <i>BRUSH GASKET</i>	KOLİ MİKTARI/Package 600 mt / koli	
EP60-03			MO60-10		
KANAT ÜST FİTİLİ <i>SASH GASKET</i>	KOLİ MİKTARI/Package 330 mt / 15 kg		KENET PVC PROFİL <i>CENTRAL LOCKING PVC PROFILE</i>	KOLİ MİKTARI/Package 6 mt / Adet	
EP60-R04			MO60-11		
KENET FİTİLİ <i>CENTRAL LOCKING GASKET</i>	KOLİ MİKTARI/Package 300 mt / 15 kg		KENET PVC PROFİL <i>CENTRAL LOCKING PVC PROFILE</i>	KOLİ MİKTARI/Package 6 mt / Adet	
EP60-05			MO60-07		
KANAT FİTİLİ <i>SASH GASKET</i>	KOLİ MİKTARI/Package 300 mt / 15 kg		KASA KANAL PLASTİĞİ LS60 04 KASA İÇİN <i>PVC PROFILE FOR LS60 04</i>	KOLİ MİKTARI/Package 6 mt / Adet	
EP38-02			MO60-08		
KASA KANAL FİTİLİ <i>FRAME GASKET</i>	KOLİ MİKTARI/Package 535 mt / 15 kg		KASA KANAL PLASTİĞİ LS60 02 ve LS60 03 İÇİN <i>PVC PROFILE FOR LS60 02 & LS60 03</i>	KOLİ MİKTARI/Package 6 mt / Adet	
INT2-02			MO60-01		
KANAL FİTİLİ <i>ADAPTER GASKET</i>	KOLİ MİKTARI/Package 350 mt / 15 kg		KENET KAPAĞI-ALT <i>INTERLOCK PROFILE-BOTTOM</i>	KOLİ MİKTARI/Package Adet / Piece	
EP38-03			MO60-02		
SABİT ÇITA FİTİLİ <i>FIXED FRAME GASKET</i>	KOLİ MİKTARI/Package 145 mt / 13 kg		KENET KAPAĞI-ÜST <i>INTERLOCK PROFILE-TOP</i>	KOLİ MİKTARI/Package Adet / Piece	

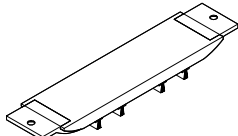
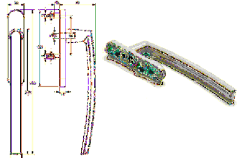

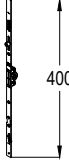
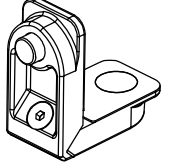
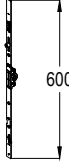
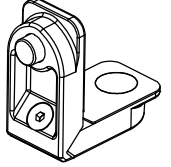
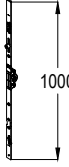
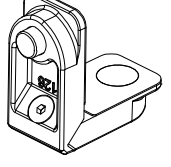
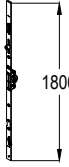
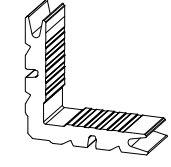
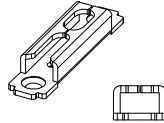
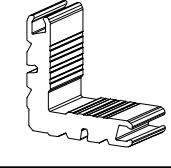
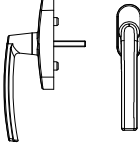
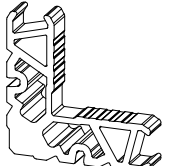
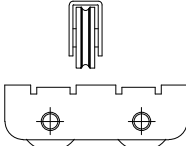
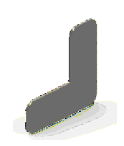
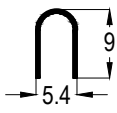
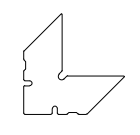
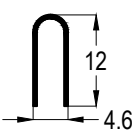
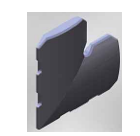
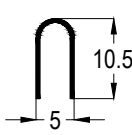
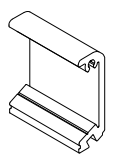

AKSESUAR LİSTESİ - ACCESSORIES LIST

FLY-KP01			MO70-INT 01		
SİNEKLİK 90 KAPAĞI FLYSCREEN CAP	KOLİ MİKTARI/Package Adet / Piece		90°DAR KENET KAPAK TAKIMI - LS7013 COVER	KOLİ MİKTARI/Package Takım / Set	
MO60-03			LS60-DB 3560		
MO60-10 İÇİN KAPAK-ALT COVER FOR MO60-10-BOTTOM	KOLİ MİKTARI/Package Adet / Piece		KANAT SABİTLEME PARÇASI SASH FIXING	KOLİ MİKTARI/Package Adet / Piece	
MO60-04			ASI-SL1520		
MO60-10 İÇİN KAPAK-ÜST COVER FOR MO60-10-TOP	KOLİ MİKTARI/Package Adet / Piece		KASA MONTAJ PARÇASI FRAME ASSEMBLY PART	KOLİ MİKTARI/Package Adet / Piece	
MO60-12			LS60-MEK1		
4 LÜ KANAT KİLİTLEME ADAPTÖR KAPAĞI MEETING STILE CAP	KOLİ MİKTARI/Package Adet / Piece		300 kg KAPASİTELİ KALDIR-SÜR MEKANİZMA LIFT & SLIDE MECHANISM	KOLİ MİKTARI/Package Takım / Set	
MO60-13			LS60-MEK1D		
KANAT DENGELEME PLASTİĞİ SASH STABILIZATION SPACER	KOLİ MİKTARI/Package Adet / Piece		300 kg KAPASİTELİ 4'LÜ KANAT MEKANİZMA LIFT & SLIDE MECHANISM	KOLİ MİKTARI/Package Takım / Set	
MO60-05D			LS60-MEK2		
HAVA KESİCİ-ALT LS60 04 KASA İÇİN CENTRAL SEALING-BOTTOM FOR LS60 04	KOLİ MİKTARI/Package Adet / Piece		200 kg KAPASİTELİ KALDIR-SÜR MEKANİZMA LIFT & SLIDE MECHANISM	KOLİ MİKTARI/Package Takım / Set	
MO60-05G			LS60-MEK2D		
HAVA KESİCİ-ALT CENTRAL SEALING-BOTTOM	KOLİ MİKTARI/Package Adet / Piece		200 kg KAPASİTELİ 4'LÜ KANAT MEKANİZMA LIFT & SLIDE MECHANISM	KOLİ MİKTARI/Package Takım / Set	
MO60-06D			ASI-LS-H01		
HAVA KESİCİ-ÜST LS60 04 KASA İÇİN CENTRAL SEALING-TOP FOR LS60 04	KOLİ MİKTARI/Package Adet / Piece		KALDIR-SÜR KOLU LIFT&SLIDE HANDLE	KOLİ MİKTARI/Package Takım / Set	
MO60-06G			ASI-LS-H01A		
HAVA KESİCİ-ÜST CENTRAL SEALING-TOP	KOLİ MİKTARI/Package Adet / Piece		KALDIR-SÜR KOLU TEKLİ LIFT&SLIDE HANDLE SINGLE	KOLİ MİKTARI/Package Adet / Piece	
MO60-19			ASI-LS-H02		
KOL PROFİL KAPAĞI HANDLE PROFILE CAP	KOLİ MİKTARI/Package alt-üst takım / set		KALDIR-SÜR KOLU KİLİTLİ LIFT&SLIDE HANDLE LOCK	KOLİ MİKTARI/Package Takım / Set	

AKSESUAR LİSTESİ - ACCESSORIES LIST

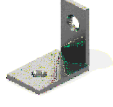
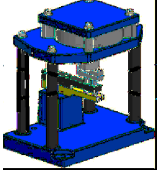
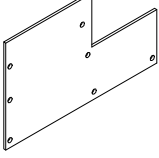
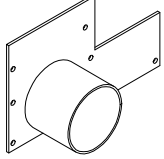
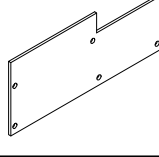
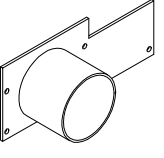
ASI-ISP15.0			ASI-PB 1119		
İSPANYOLET KİLİTLEME (400mm) - 15.5 AKS <i>MULTI POINT LOCK</i>	KOLİ MİKTARI/Package Adet / Piece		KÖŞE BAĞLANTI <i>CORNER JOINT</i>	KOLİ MİKTARI/Package 11 x 19 mm	
ASI-ISP15.1			ASI-PB 1124 (MON / 0404)		
İSPANYOLET KİLİTLEME (600mm) - 15.5 AKS <i>MULTI POINT LOCK</i>	KOLİ MİKTARI/Package Adet / Piece		KÖŞE BAĞLANTI <i>CORNER JOINT</i>	KOLİ MİKTARI/Package 11 x 24 mm	
ASI-ISP15.2			ASI-PB 1126		
İSPANYOLET KİLİTLEME (1000mm)-15.5 AKS <i>MULTI POINT LOCK</i>	KOLİ MİKTARI/Package Adet / Piece		PİMLİ KÖŞE BAĞLANTI <i>CORNER JOINT</i>	KOLİ MİKTARI/Package 11 x 26 mm	
ASI-ISP15.3			ASI-KT 1126		
İSPANYOLET KİLİTLEME (1800mm) - 15.5 AKS <i>MULTI POINT LOCK</i>	KOLİ MİKTARI/Package Adet / Piece		KÖŞE TAKOZU <i>CORNER JOINT</i>	KOLİ MİKTARI/Package Adet / Piece	
ASI-ISP K03			ASI-KT 1429		
İSPANYOLET KİLİT KARŞILIK <i>MULTI POINT LOCK STRIKER</i>	KOLİ MİKTARI/Package Adet / Piece		KÖŞE TAKOZU <i>CORNER JOINT</i>	KOLİ MİKTARI/Package Adet / Piece	
ASI-WH 002			ASI-KT 2307		
İSPANYOLET KİLİTLEME KOL <i>MULTI POINT LOCK HANDLE</i>	KOLİ MİKTARI/Package Adet / Piece		KÖŞE TAKOZU <i>CORNER JOINT</i>	KOLİ MİKTARI/Package Adet / Piece	
ASI-SR 04			ASI-SB 19.1		
NORMAL SÜRME RULMAN (U TİPİ RAY) <i>NORMAL SLIDING ROLLER FOR RAIL TYPE - U</i>	KOLİ MİKTARI/Package Adet / Piece		KÖŞE GÖNYESİ <i>CORNER ALIGNMENT</i>	KOLİ MİKTARI/Package 1000 Adet / Piece	
ASI-INR 01 Sineklik için <i>for Flyscreen Sliding</i>			ASI-SB 34		
ÇELİK RAY <i>STEEL RAIL</i>	KOLİ MİKTARI/Package 6 mt / Adet		KÖŞE GÖNYESİ <i>CORNER ALIGNMENT</i>	KOLİ MİKTARI/Package 1000 Adet / Piece	
ASI-INR 02 Normal Sürme için <i>for Normal Sliding</i>			EM 12-54		
ÇELİK RAY <i>STEEL RAIL_LS60-SD</i>	KOLİ MİKTARI/Package 6 mt / Adet		KÖŞE GÖNYESİ <i>CORNER ALIGNMENT</i>	KOLİ MİKTARI/Package 1000 Adet / Piece	
ASI-INR 03 Kaldır-Sür Sürme için <i>for Lift&Sliding</i>			ASI-DB 9143		
ÇELİK RAY <i>STEEL RAIL_LS60-LSDR</i>	KOLİ MİKTARI/Package 6 mt / Adet		DİK BAĞLANTI <i>T JOINT</i>	KOLİ MİKTARI/Package Adet / Piece	

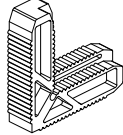
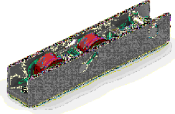
AKSESUAR LİSTESİ - ACCESSORIES LIST

ASI-P 100.1			501 EKO PANÇ		
DİK BAĞLANTI <i>T JOINT</i>	KOLİ MİKTARI/Package 250 Adet / Piece		KÖŞE PİMLİ BAĞLANTI PANÇ MAKİNESİ <i>PUNCH MACHINE FOR CORNER JOINT WITH PIN</i>	KOLİ MİKTARI/Package Adet / Piece	
DR-KAP 01					
DRENAJ KANAL KAPAK <i>WATER DRAINAGE COVER</i>	KOLİ MİKTARI/Package Adet / Piece				
DR-KAP 02					
DRENAJ KANAL KAPAK <i>WATER DRAINAGE COVER</i>	KOLİ MİKTARI/Package Adet / Piece				
DR-KAP 03					
DRENAJ KANAL KAPAK <i>WATER DRAINAGE COVER</i>	KOLİ MİKTARI/Package Adet / Piece				
DR-KAP 04					
DRENAJ KANAL KAPAK <i>WATER DRAINAGE COVER</i>	KOLİ MİKTARI/Package Adet / Piece				
ASI-5025					
SİNEKLİK FİTİLİ <i>FLYSCREEN GASKET</i>	KOLİ MİKTARI/Package 100 mt				
ASI-BZ 5060					
SİNEKLİK KANAT RULMAN <i>FLYSCREEN SASH ROLLER</i>	KOLİ MİKTARI/Package Adet / Piece				
ASI-BZ 5007					
SİNEKLİK KÖŞE TAKOZU <i>FLYSCREEN CORNER JOINT</i>	KOLİ MİKTARI/Package Adet / Piece				
ASI-SR 02R					
AYARLI ÇİFTLİ RULMAN (SİNEKLİK İÇİN) <i>DOUBLE SLIDING ROLLER FOR FLY SCREEN</i>	KOLİ MİKTARI/Package Adet / Piece				
ASI-WDC 01					
YAĞMUR TAHLİYE KAPAĞI <i>WATER REJECT COVER</i>	KOLİ MİKTARI/Package Adet / Piece				

LS60

YALITIMLI KALDIR-SÜR SİSTEM
THERMAL LIFT&SLIDE SYSTEM

ASISTAL

PROFİL DETAYLARI
PROFILE DETAILS



LS60

YALITIMLI KALDIR-SÜR SİSTEM
THERMAL LIFT&SLIDE SYSTEM

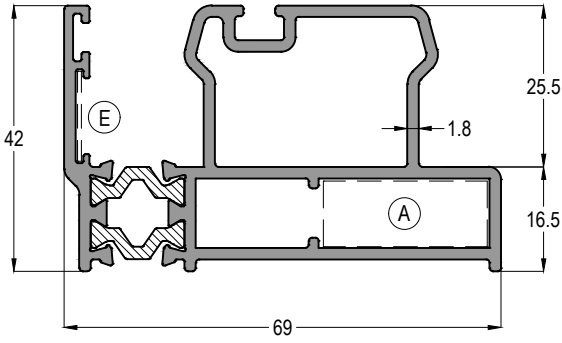
ASISTAL



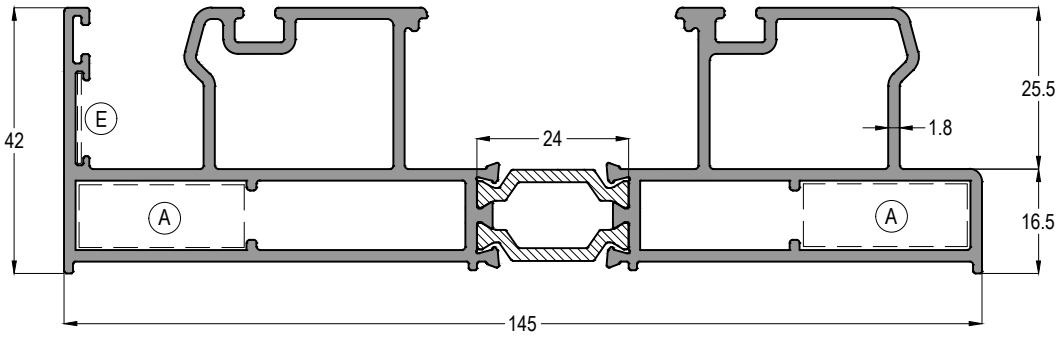

LS60 01

 ASI-KT 1126 - ASI-PB 1126	 ASI-SB 19.1	AĞIRLIK / Weight 1,591 kg/mt
--	--	---------------------------------



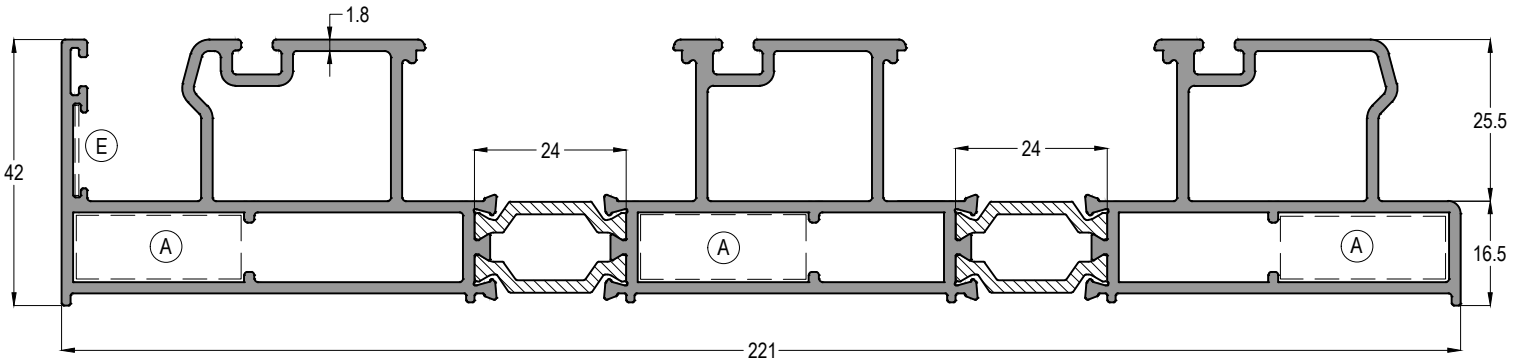

LS60 02

 ASI-KT 1126 - ASI-PB 1126	 ASI-SB 19.1	AĞIRLIK / Weight 2,822 kg/mt
--	--	---------------------------------



LS60 03

 ASI-KT 1126 - ASI-PB 1126	 ASI-SB 19.1	AĞIRLIK / Weight 4,210 kg/mt
--	--	---------------------------------

Profil ağırlıklarımız teorik olup; teslim anındaki tartımız geçerlidir.
Profile weights are theoretical and the weight at the time of delivery is valid.

LS60

YALITIMLI KALDIR-SÜR SİSTEM
THERMAL LIFT&SLIDE SYSTEM

ASISTAL

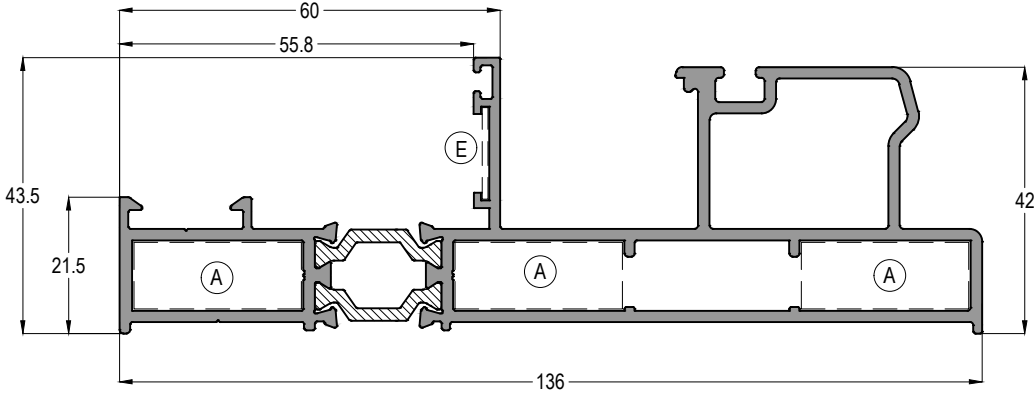

LS60 118



ASI-KT 1126 - ASI-PB 1126

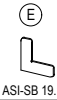

ASI-SB 19.1

AĞIRLIK / Weight

2,345 kg/mt

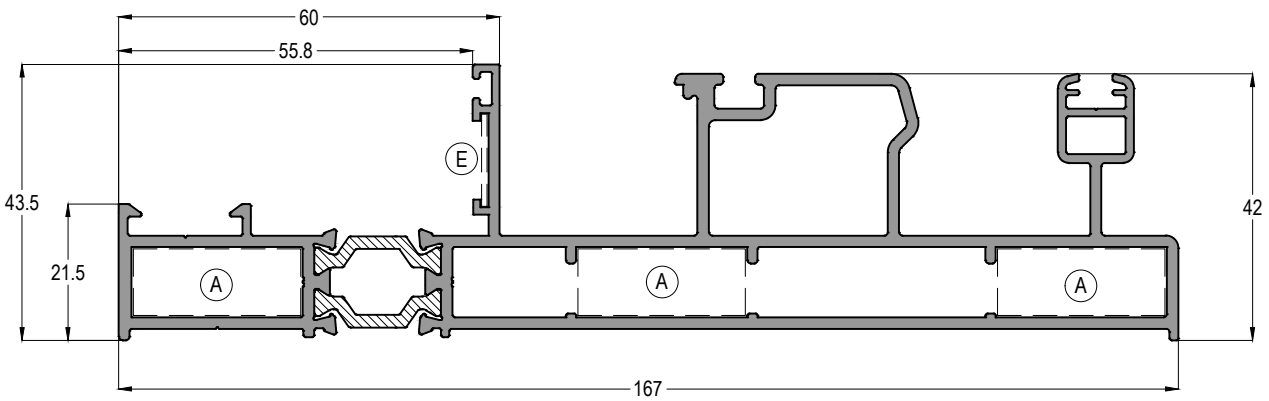

LS60 119



ASI-KT 1126 - ASI-PB 1126

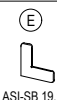

ASI-SB 19.1

AĞIRLIK / Weight

2,895 kg/mt

LS60

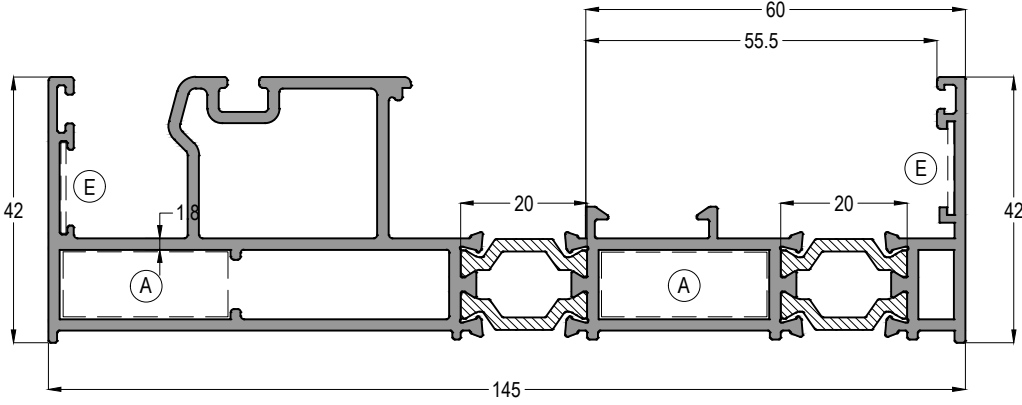

YALITIMLI KALDIR-SÜR SİSTEM
THERMAL LIFT&SLIDE SYSTEM

ASISTAL





NOT: LS60 04 KASA, CAM KALINLIĞI 24mm DEN FAZLA OLAN CAMLARIN MONTAJI İÇİN UYGUN DEĞİLDİR

*LS60 04 CASE, NOT SUITABLE FOR INSTALLATION
FOR GLASSES WITH GLASS THICKNESS MORE THAN 24mm*

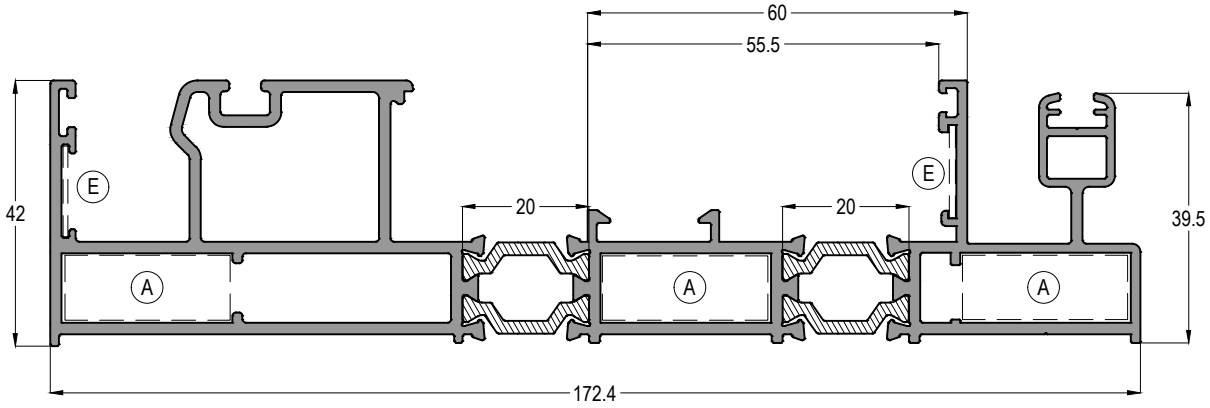
LS60 04		AĞIRLIK / Weight
		2,764 kg/mt
ASI-KT 1126 ~ ASI-PB 1126	ASI-SB 19.1	



LS60 104		AĞIRLIK / Weight
		3,223 kg/mt
ASI-KT 1126 ~ ASI-PB 1126	ASI-SB 19.1	

LS60

YALITIMLI KALDIR-SÜR SİSTEM
THERMAL LIFT&SLIDE SYSTEM

ASISTAL

LS60 - 1,4mm KASALAR

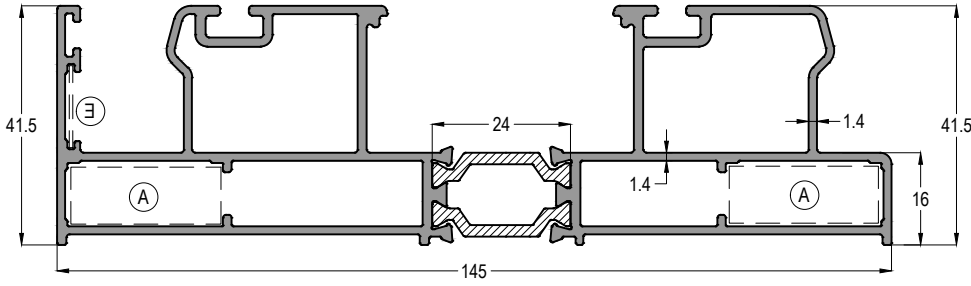

LS60 05



AĞIRLIK / Weight
2,448 kg/mt

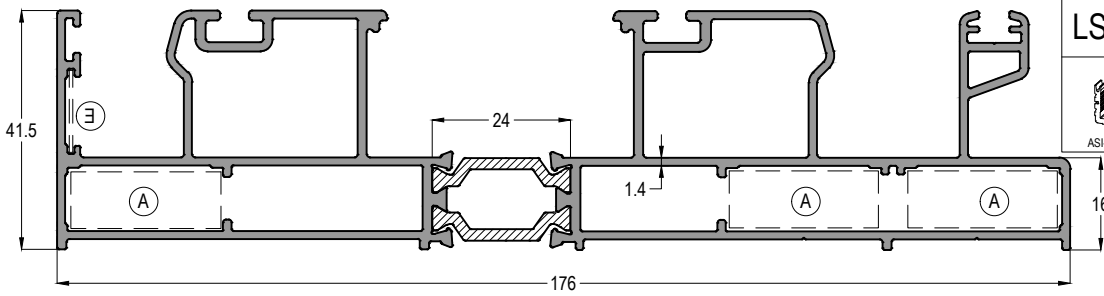

LS60 05F



AĞIRLIK / Weight
2,952 kg/mt

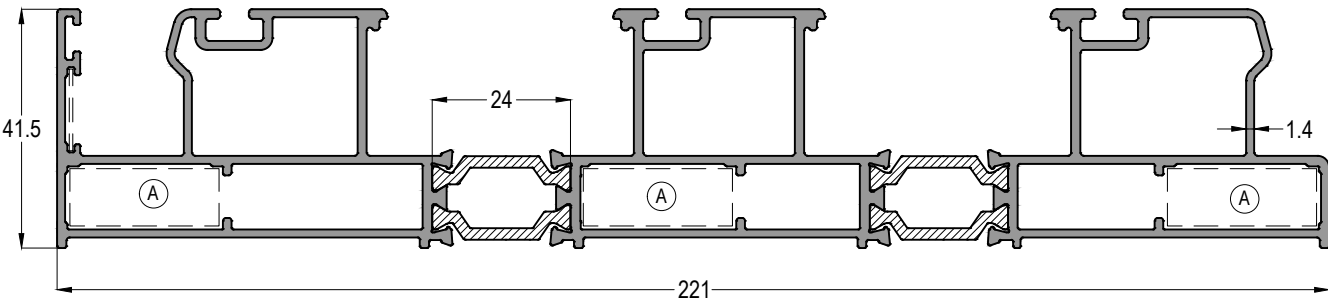

LS60 09

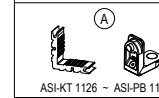

AĞIRLIK / Weight
3,698 kg/mt

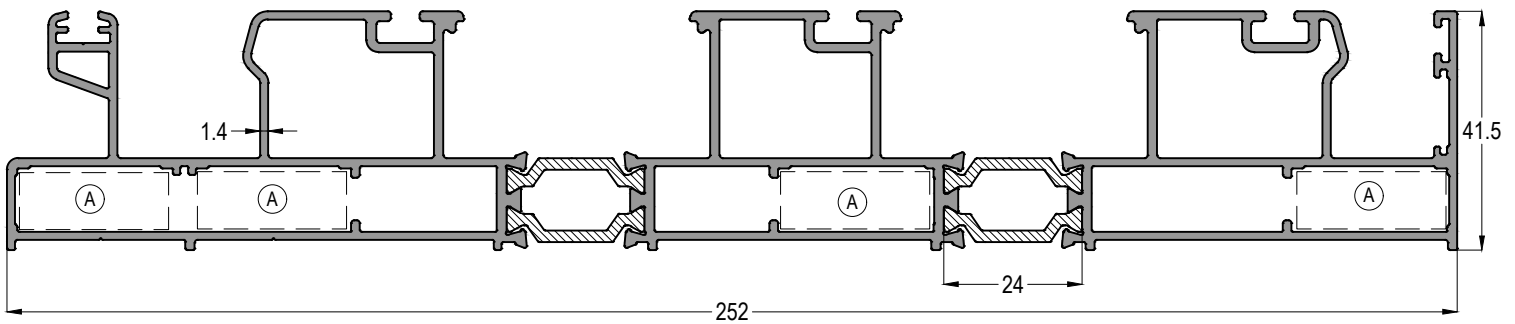

LS60 09F



AĞIRLIK / Weight
4,202 kg/mt

Profil ağırlıklarımız teorik olup; teslim anındaki tartımız geçerlidir.
Profile weights are theoretical and the weight at the time of delivery is valid.

LS60

YALITIMLI KALDIR-SÜR SİSTEM
THERMAL LIFT&SLIDE SYSTEM

ASISTAL

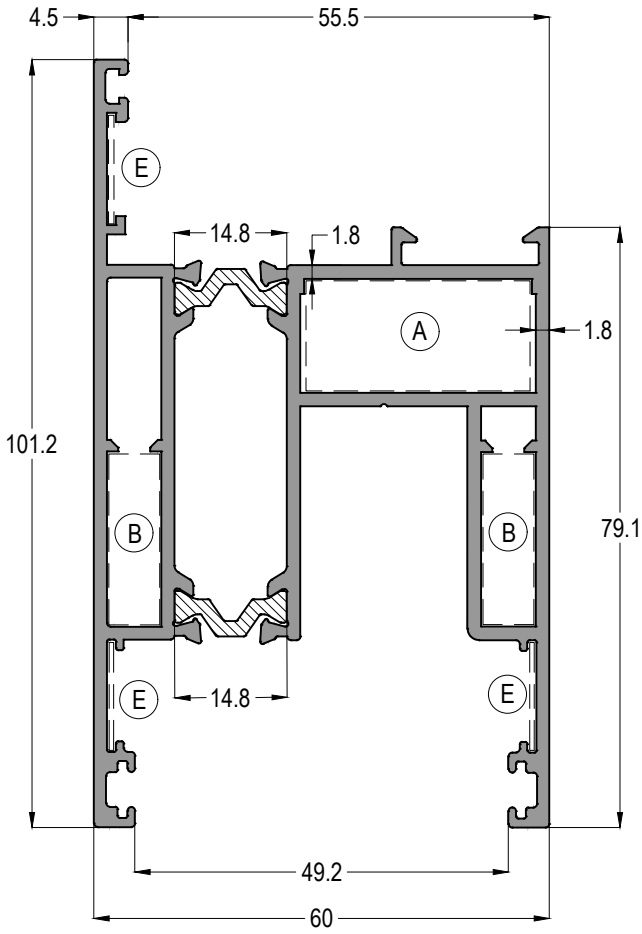

LS60 11

Jx cm ⁴	Jy cm ⁴
43,22	49,37

AĞIRLIK / Weight

2,312 kg/mt



ASI-KT 1429

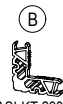

ASI-KT 2307



ASI-SB 19.1

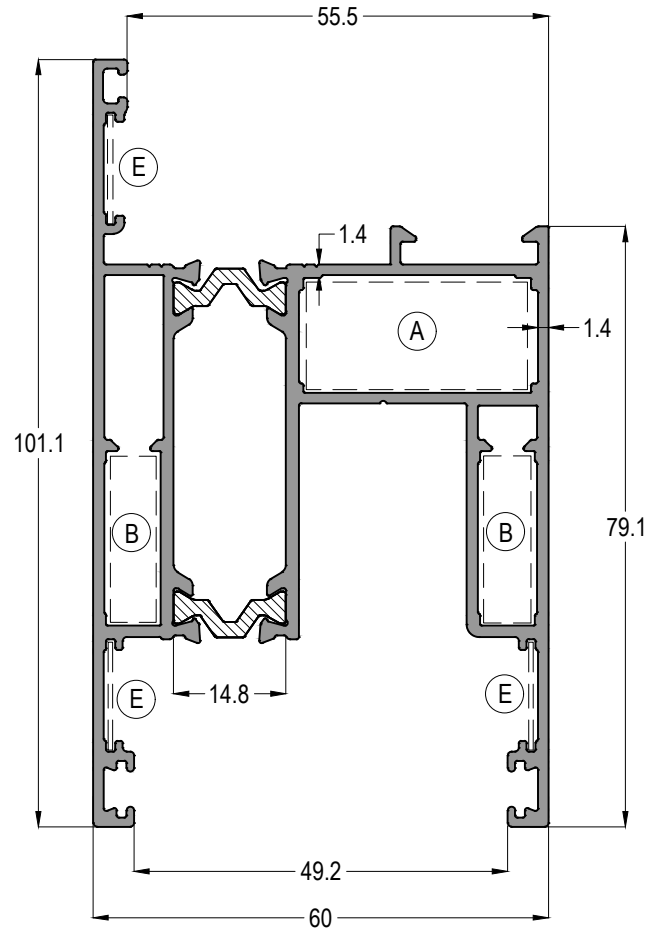

LS60 12 - 1,4mm

Jx cm ⁴	Jy cm ⁴
36,03	47,29

AĞIRLIK / Weight

2,080 kg/mt



ASI-KT 1429



ASI-KT 2307

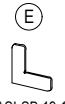

ASI-SB 19.1

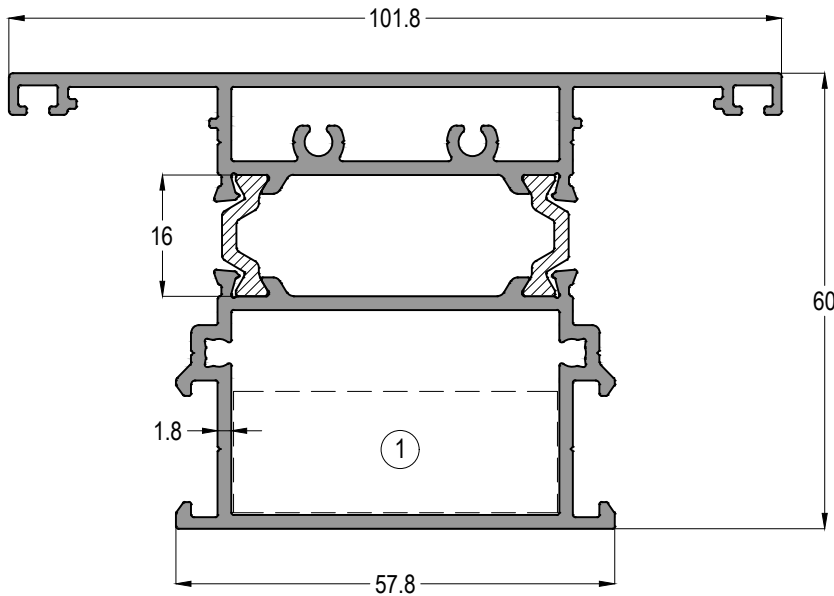

TH60 23



ASI-DB 9143

AĞIRLIK / Weight



2,128 kg/mt

LS60

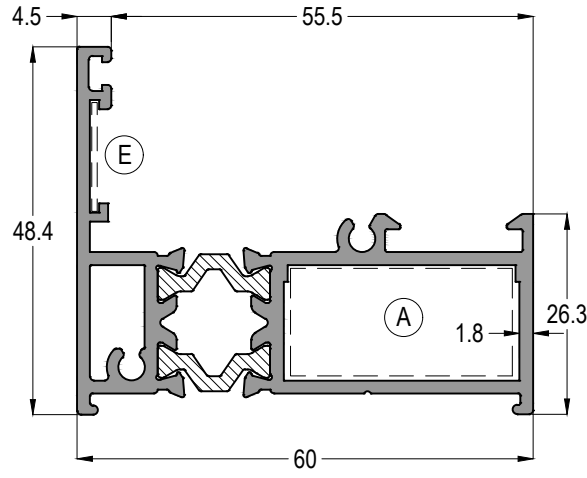

YALITIMLI KALDIR-SÜR SİSTEM
THERMAL LIFT&SLIDE SYSTEM

ASISTAL

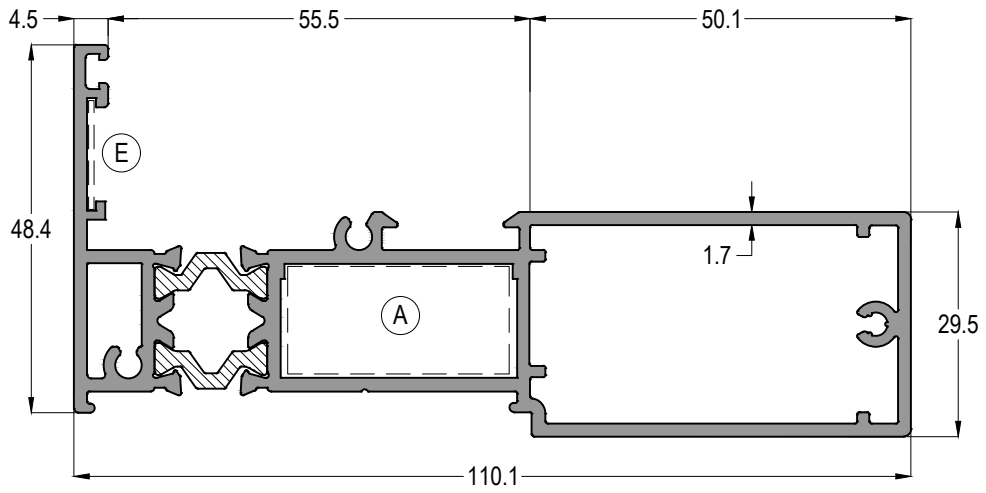

LS60 112		Jx cm ⁴	Jy cm ⁴
		19,15	5,20
 ASI-KT 1429	 ASI-SB 19.1	AĞIRLIK / Weight	
		1,244 kg/mt	



LS60 113		Jx cm ⁴	Jy cm ⁴
		99,15	9,16
 ASI-KT 1429	 ASI-SB 19.1	AĞIRLIK / Weight	
		1,933 kg/mt	



LS60

YALITIMLI KALDIR-SÜR SİSTEM
THERMAL LIFT&SLIDE SYSTEM

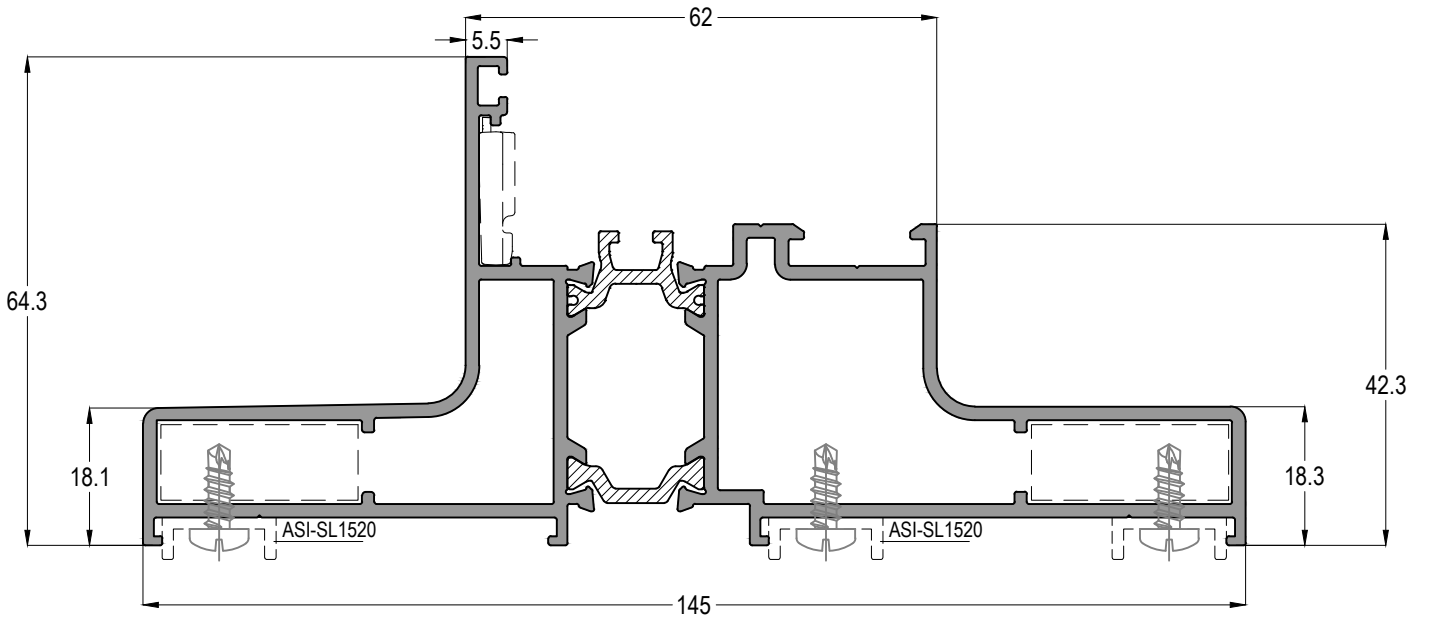
ASISTAL



LS60 62

		AĞIRLIK / Weight
ASI-KT 1126 ~ ASI-PB 1126	ASI-FUJI 2000	2,418 kg/mt

LS60

YALITIMLI KALDIR-SÜR SİSTEM
THERMAL LIFT&SLIDE SYSTEM

ASISTAL

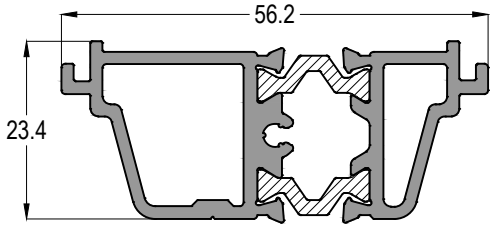

LS60 41



MO60-12

AĞIRLIK / Weight

0,987 kg/mt

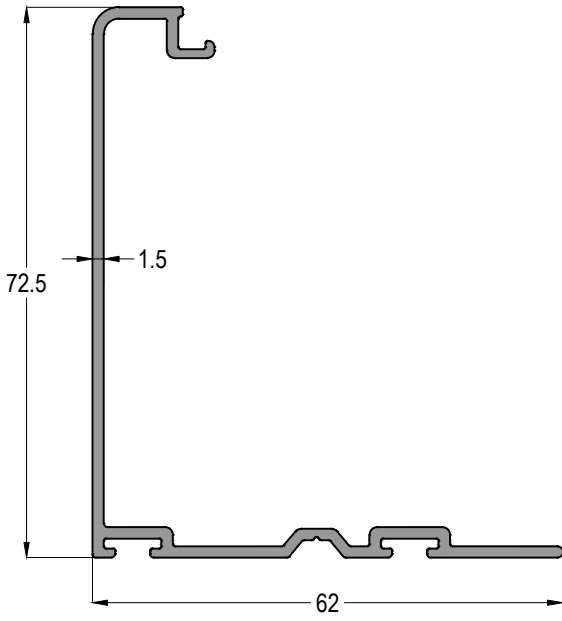

LS60 42

AĞIRLIK / Weight

0,670 kg/mt

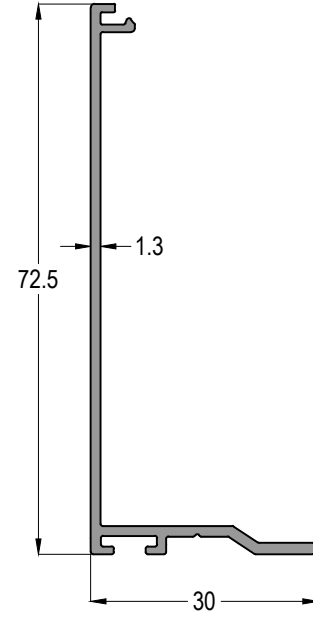

LS60 45

AĞIRLIK / Weight

0,404 kg/mt

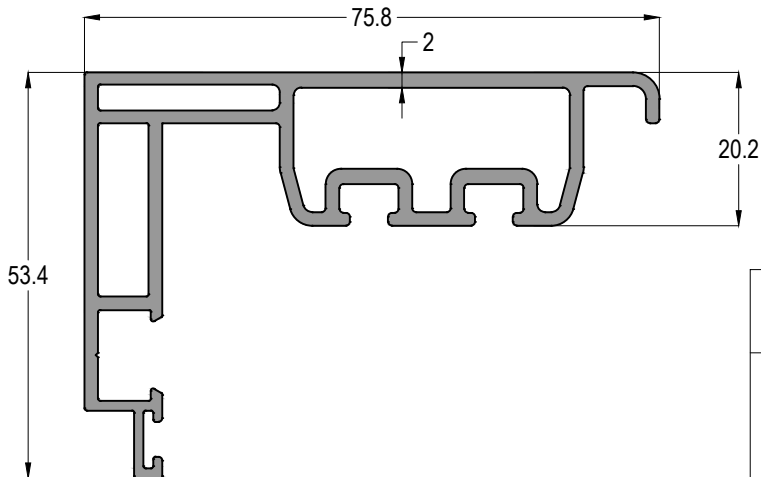

LS60 43

AĞIRLIK / Weight

1,434 g/mt

LS60

YALITIMLI KALDIR-SÜR SİSTEM
THERMAL LIFT&SLIDE SYSTEM

ASISTAL

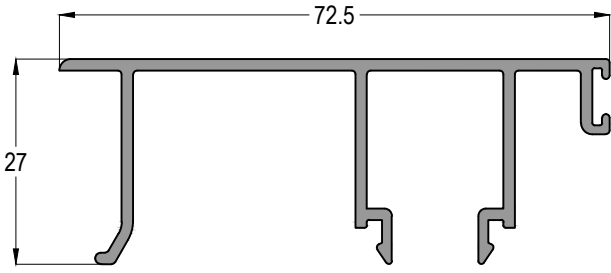

LS60 31

AĞIRLIK / Weight

0,686 kg/mt

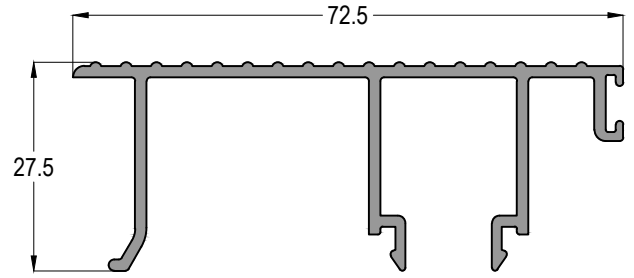

LS60 32

AĞIRLIK / Weight

0,710 kg/mt

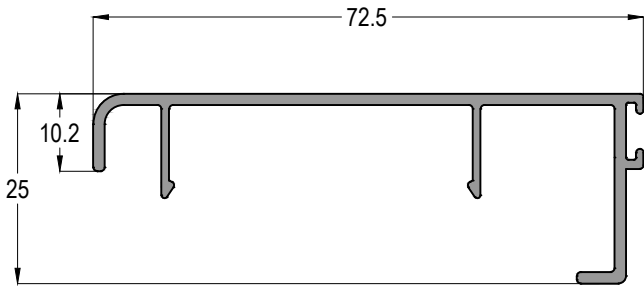

LS60 33

AĞIRLIK / Weight

0,523 kg/mt

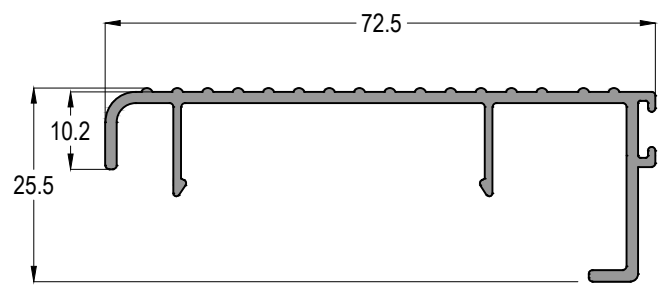

LS60 34

AĞIRLIK / Weight

0,545 kg/mt

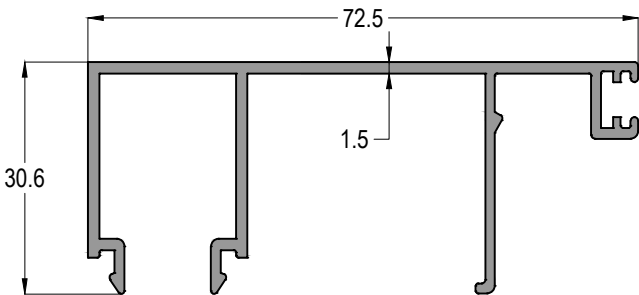

LS60 40

AĞIRLIK / Weight

0,724 kg/mt

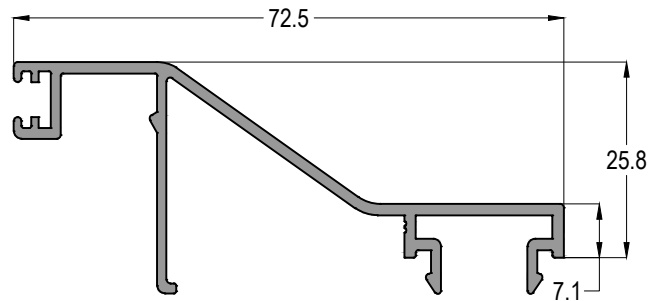

LS60 46

AĞIRLIK / Weight

0,570 kg/mt

LS60

YALITIMLI KALDIR-SÜR SİSTEM
THERMAL LIFT&SLIDE SYSTEM

ASISTAL

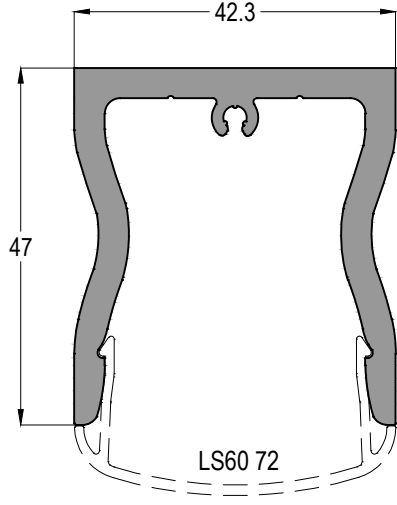

LS60 71	
 MO60-19	AĞIRLIK / Weight 1,430 kg/mt

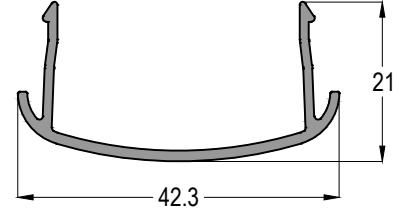

LS60 72	
	AĞIRLIK / Weight 0,296 kg/mt

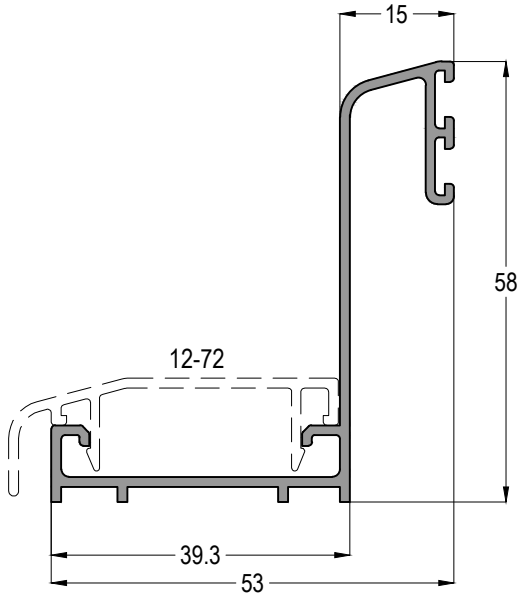

12-71	
	AĞIRLIK / Weight 0,545 kg/mt

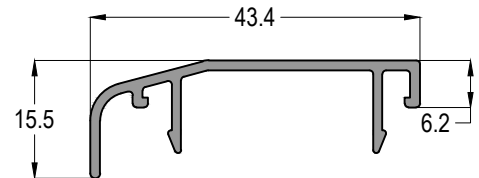

12-72	
	AĞIRLIK / Weight 0,286 kg/mt



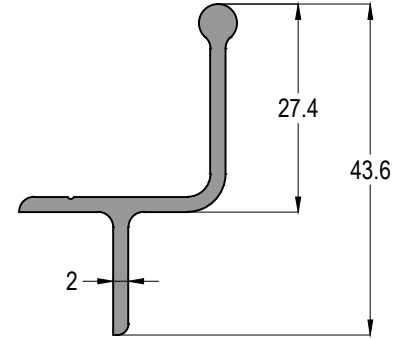
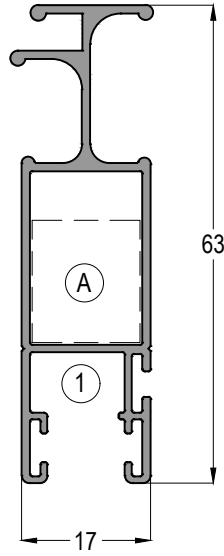
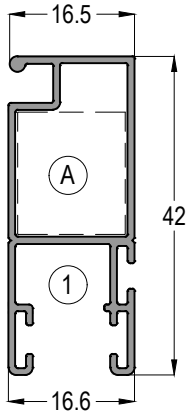

LS60

YALITIMLI KALDIR-SÜR SİSTEM
THERMAL LIFT&SLIDE SYSTEM





ASISTAL



15-304216-09

		AĞIRLIK / Weight
		0,352 kg/mt

15-306317-11



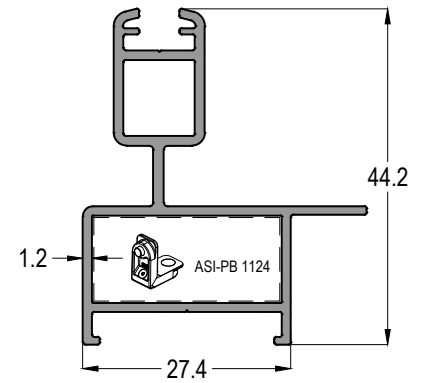
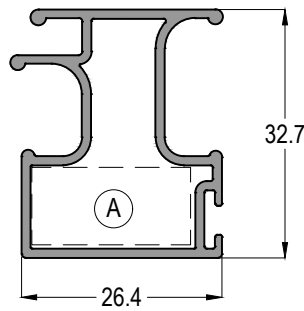
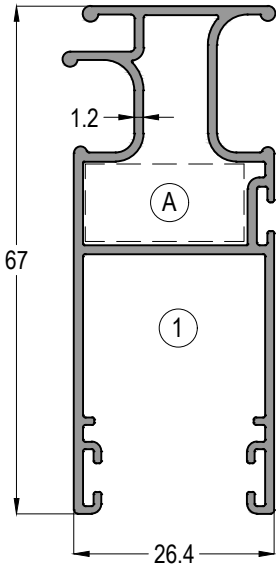

		AĞIRLIK / Weight
		0,561 kg/mt

LS60 61





0,391 kg/mt



13-09986

		AĞIRLIK / Weight
		0,741 kg/mt

SL34T-52

		AĞIRLIK / Weight
		0,469 kg/mt

1042

0,553 kg/mt

LS60

YALITIMLI KALDIR-SÜR SİSTEM
THERMAL LIFT&SLIDE SYSTEM

ASISTAL

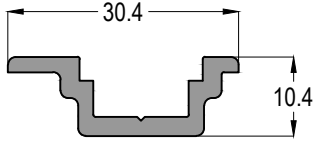

LS60 44

0,285 kg/mt

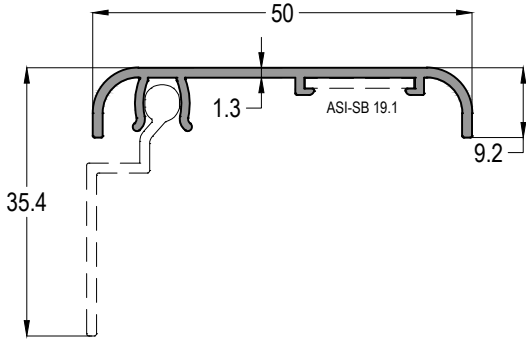

12-52

0,279 kg/mt

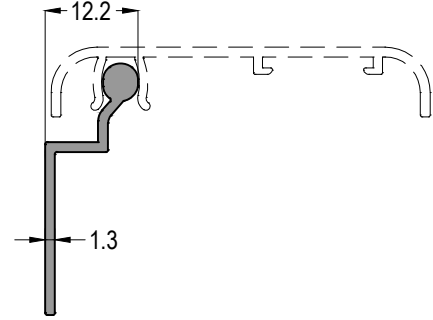

12-53

0,176 kg/mt

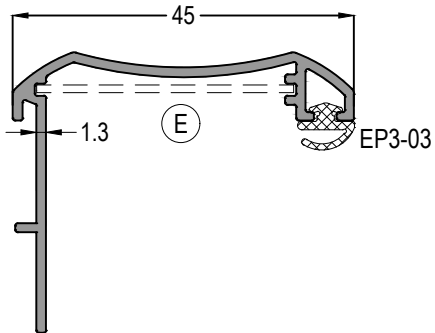

12-57

0,358 kg/mt

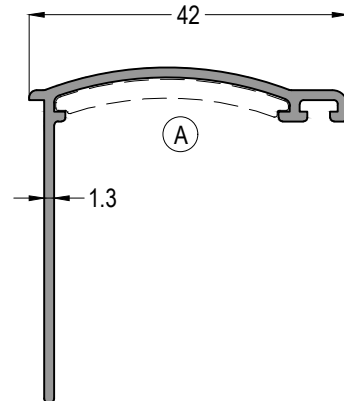

12-54

0,326 kg/mt

LS60

YALITIMLI KALDIR-SÜR SİSTEM
THERMAL LIFT&SLIDE SYSTEM

ASISTAL

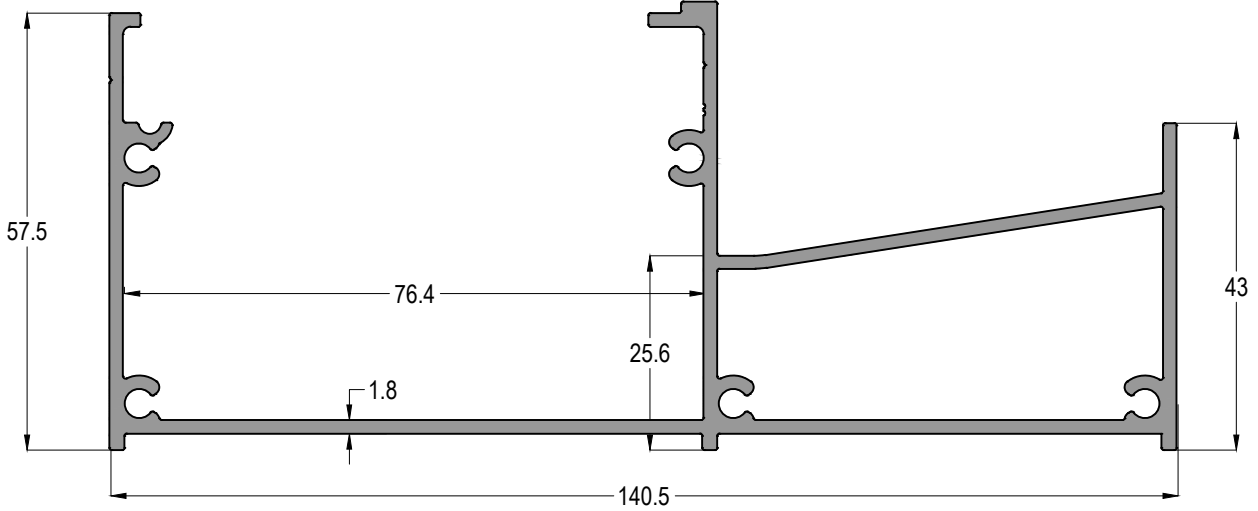

DR-001

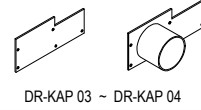

AĞIRLIK / Weight

1,998 kg/mt

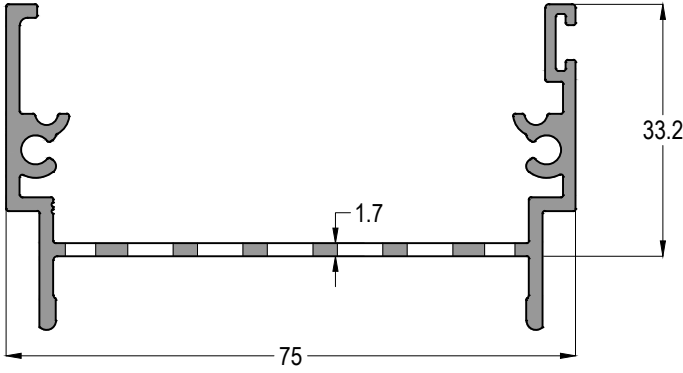

DR-002

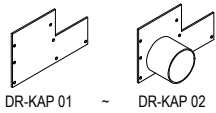

AĞIRLIK / Weight

0,918 kg/mt

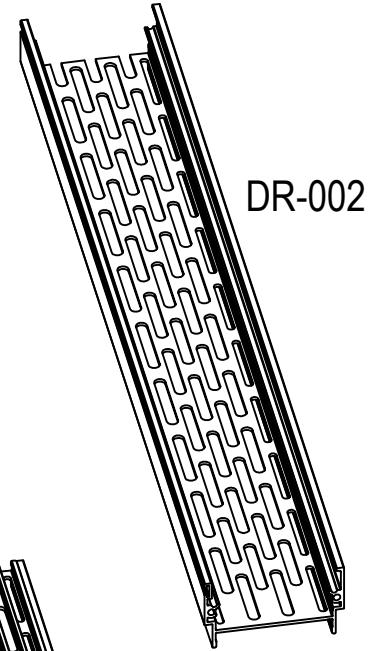

DR-002

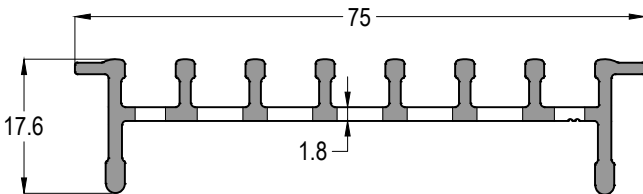

DR-003

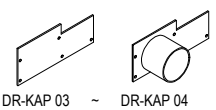

AĞIRLIK / Weight

0,724 kg/mt

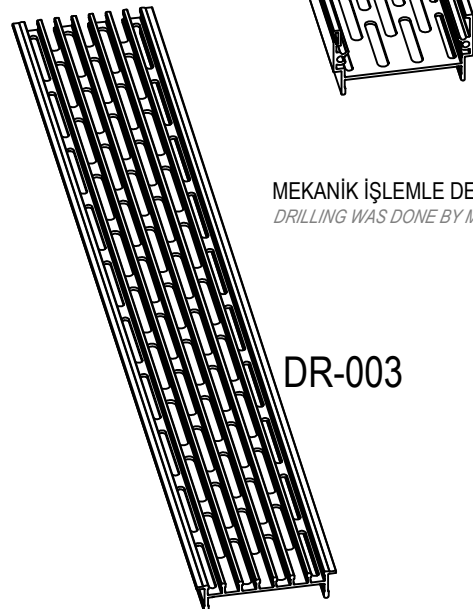

MEKANİK İŞLEMLE DELME YAPILMIŞTIR
DRILLING WAS DONE BY MECHANICAL PROCESS

DR-003

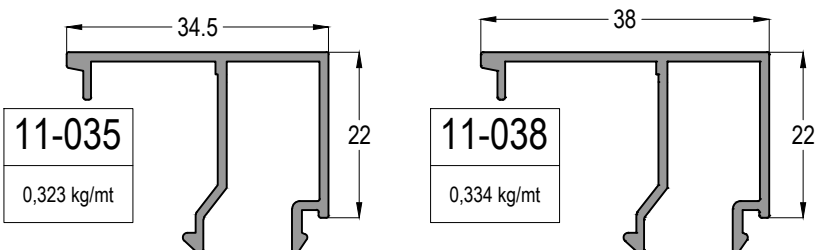
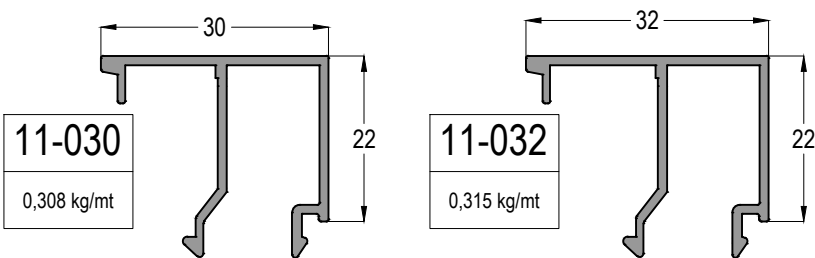
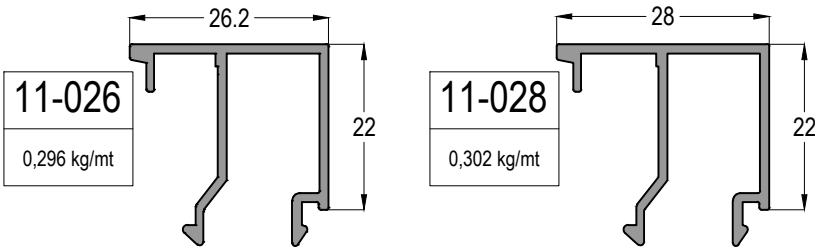
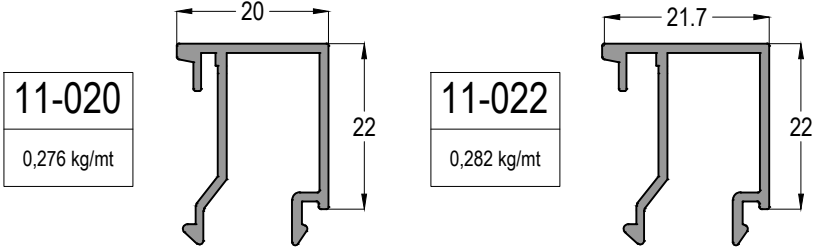
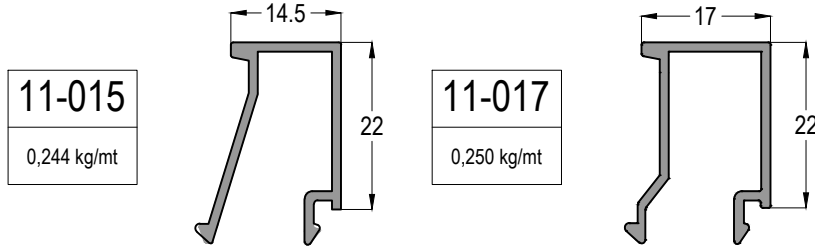
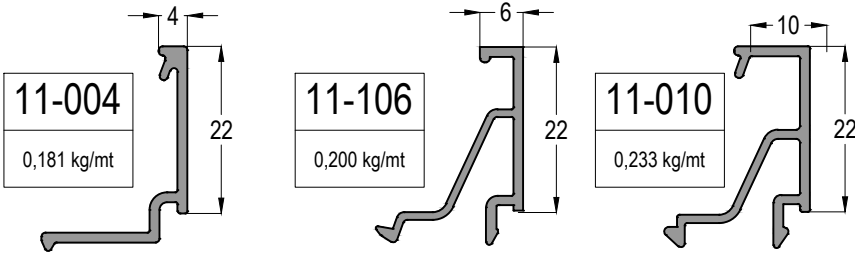

CAM KALINLIĞINA GÖRE CAM ÇİTASI SEÇİM TABLOSU
Glazing Bead Selection Table according to the Glass Thickness

CAM KALINLIĞI Glass Thickness (mm)	CAM ÇİTASI Glazing Bead	İÇ CAM FITİLİ Glass Gasket (IN)	DIŞ CAM FITİLİ Glass Gasket (OUT)
10	11-038	EP2-02	EP1-01
11	11-038	EP2-01	EP1-01
12	11-035	EP2-03	EP1-01
13	11-035	EP2-02	EP1-01
14	11-035	EP2-01	EP1-01
15	11-032	EP2-03	EP1-01
16	11-032	EP2-02	EP1-01
17	11-032	EP2-01	EP1-01
18	11-030	EP2-02	EP1-01
19	11-030	EP2-01	EP1-01
20	11-028	EP2-02	EP1-01
21	11-028	EP2-01	EP1-01
22	11-026	EP2-02	EP1-01
23	11-026	EP2-01	EP1-01
24	11-022	EP2-03	EP1-01
25	11-022	EP2-02	EP1-01
26	11-022	EP2-01	EP1-01
28	11-020	EP2-02	EP1-01
29	11-020	EP2-01	EP1-01
30	11-017	EP2-03	EP1-01
31	11-017	EP2-02	EP1-01
32	11-017	EP2-01	EP1-01
33	11-015	EP2-02	EP1-01
34	11-015	EP2-01	EP1-01
38	11-010	EP2-02	EP1-01
39	11-010	EP2-01	EP1-01
40	11-106	EP2-03	EP1-01
42	11-106	EP2-02	EP1-01
43	11-106	EP2-01	EP1-01
44	11-004	EP2-02	EP1-01
45	11-004	EP2-02	EP1-01
46	11-004	KC-02	EP1-01



AÇILIM TİPLERİ NORMAL SÜRME - OPENING TYPES NORMAL SLIDING

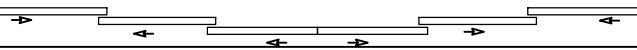
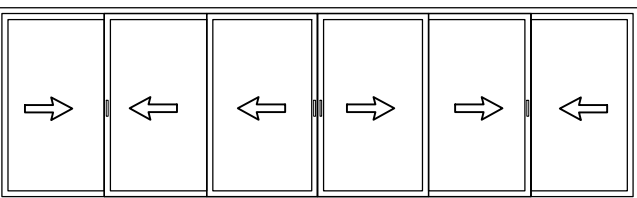
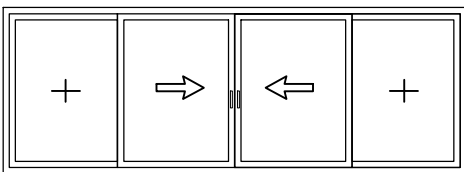
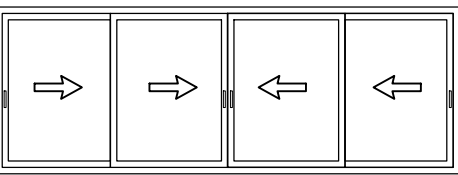
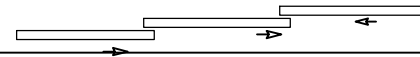
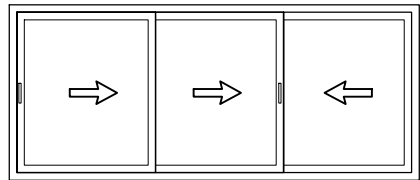
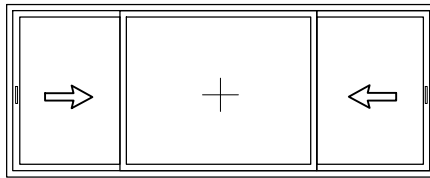
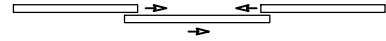
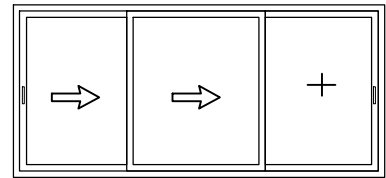
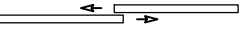
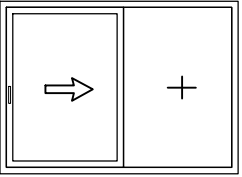
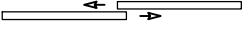
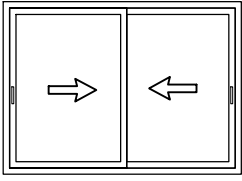



AÇILIM TIPLERİ KALDIR-SÜR SÜRME - OPENING TYPES LIFT & SLIDING

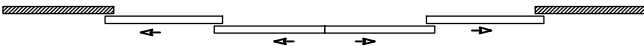
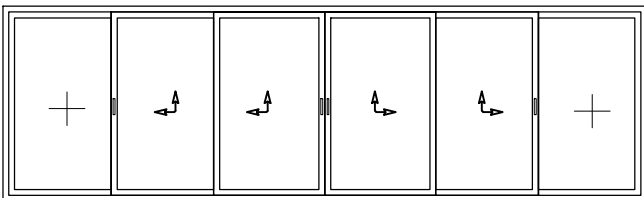
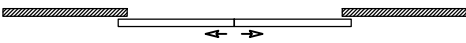
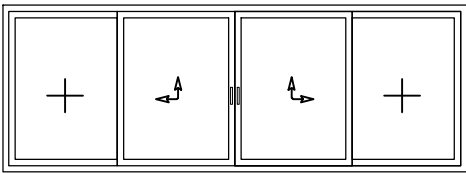
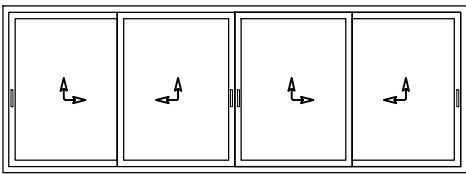
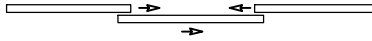
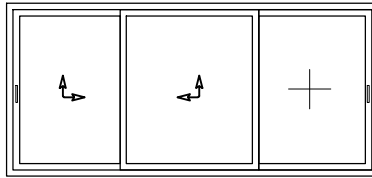
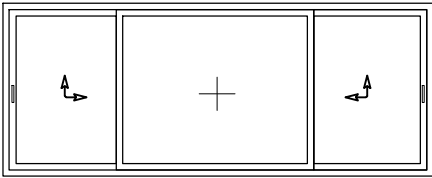
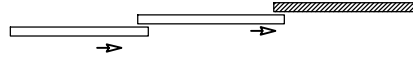
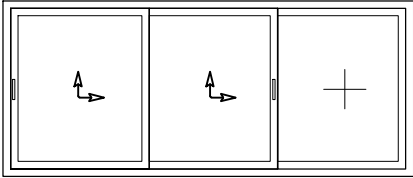
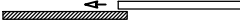
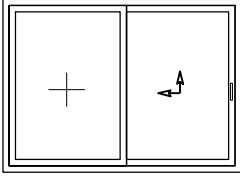
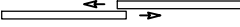
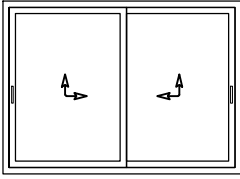

RÜZGAR YÜKÜNE GÖRE MAKSİMUM KANAT EBATLARI

MAXIMUM SASH DIMENSIONS FOR GIVEN WIND PRESSURE

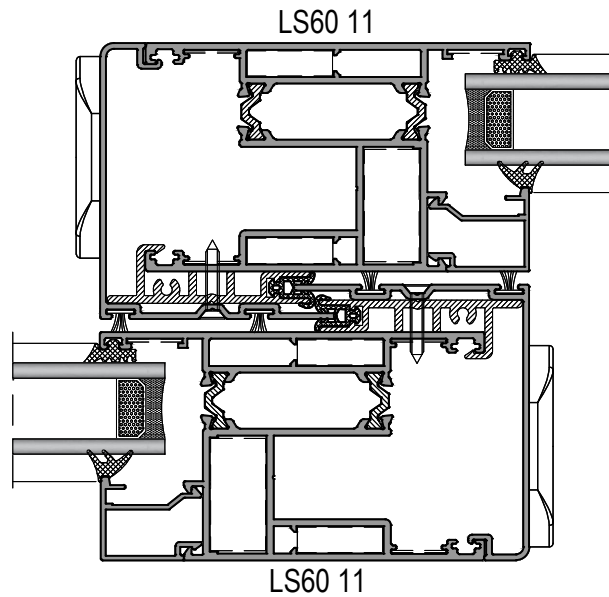
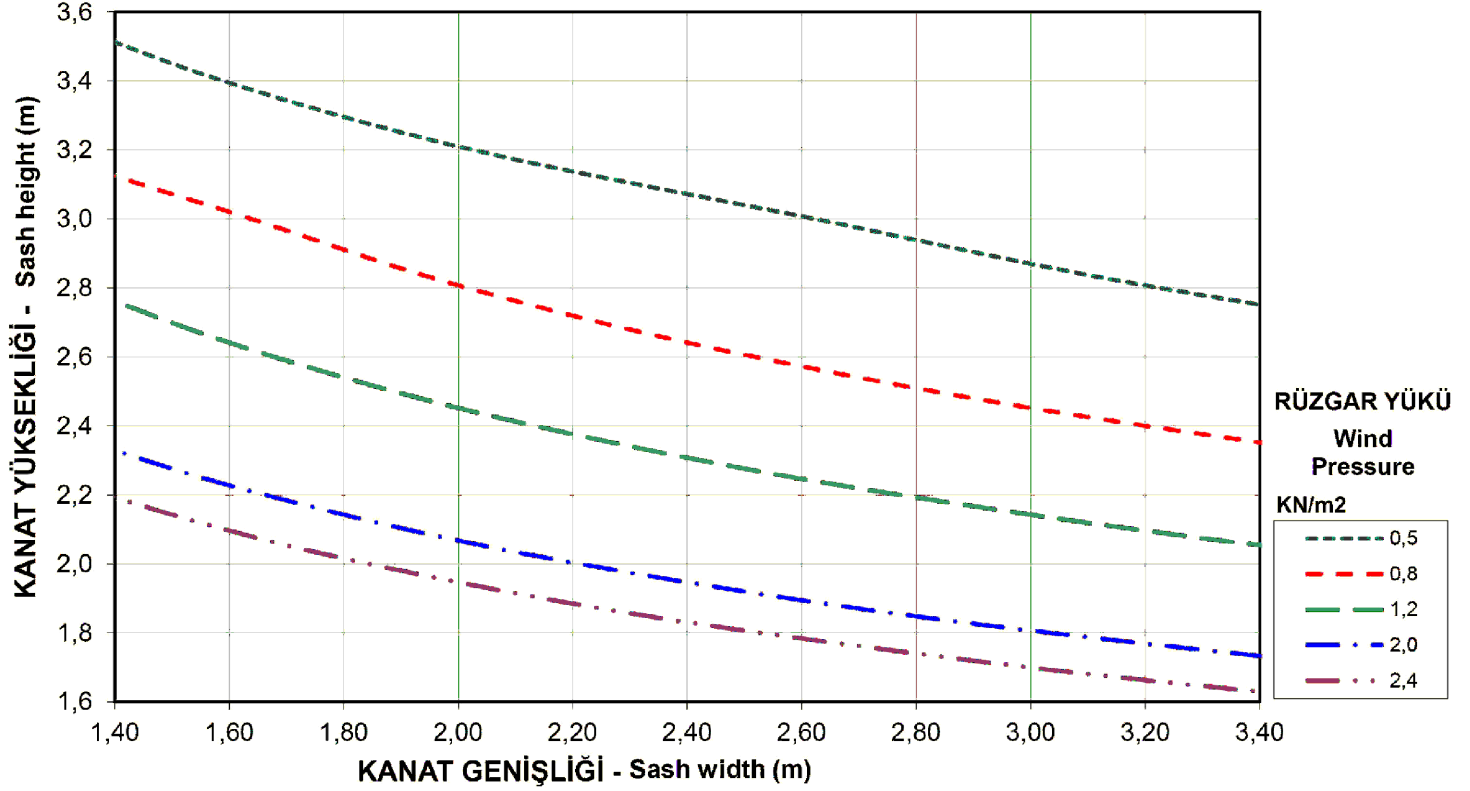

KANAT EBATLARI BELİRLENİRKEN MEKANİZMANIN TAŞIMA KAPASİTESİNİ GEÇMEMESİNE DİKKAT EDİLMELİDİR

WHILE THE SASH DIMENSIONS DETERMINED, SASH WEIGHT MUST BE LESS THAN ROLLER CARRY CAPACITY

RÜZGAR YÜKÜNE GÖRE MAKSİMUM KANAT EBATLARI

MAXIMUM SASH DIMENSIONS FOR GIVEN WIND PRESSURE

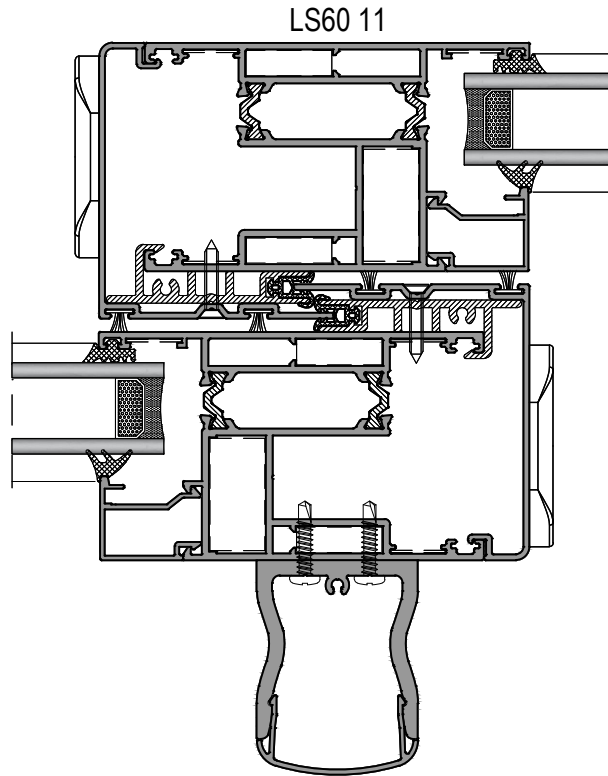
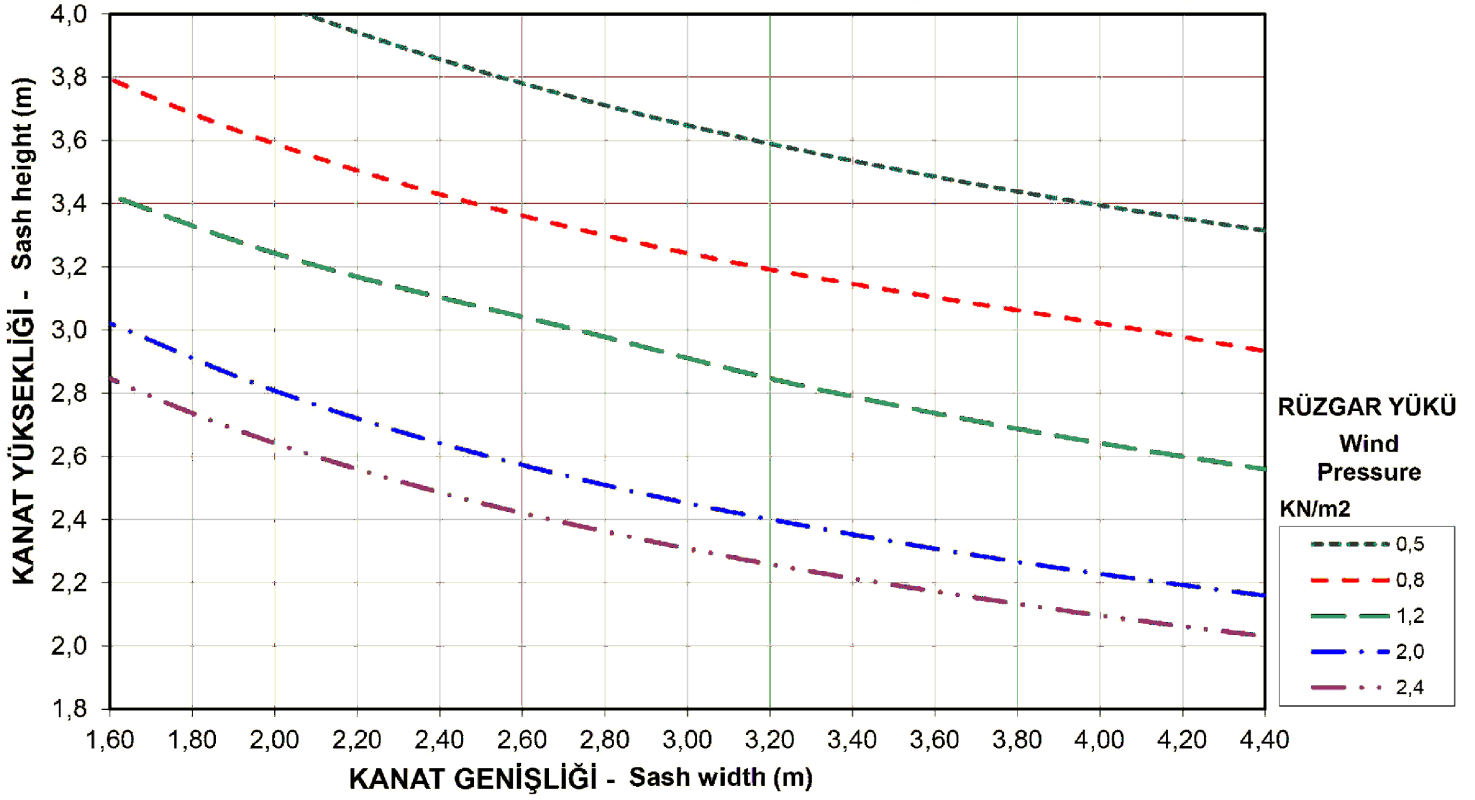

KANAT EBATLARI BELİRLENİRKEN MEKANİZMANIN TAŞIMA KAPASİTESİNİ GEÇMEMESİNE DİKKAT EDİLMELİDİR

WHILE THE SASH DIMENSIONS DETERMINED, SASH WEIGHT MUST BE LESS THAN ROLLER CARY CAPACITY

LS60

YALITIMLI KALDIR-SÜR SİSTEM
THERMAL LIFT&SLIDE SYSTEM

ASISTAL

SİSTEM DETAYLARI
SYSTEM DETAILS

LS60 - 1,8mm

YALITIMLI KALDIR-SÜR SİSTEM
THERMAL LIFT&SLIDE SYSTEM

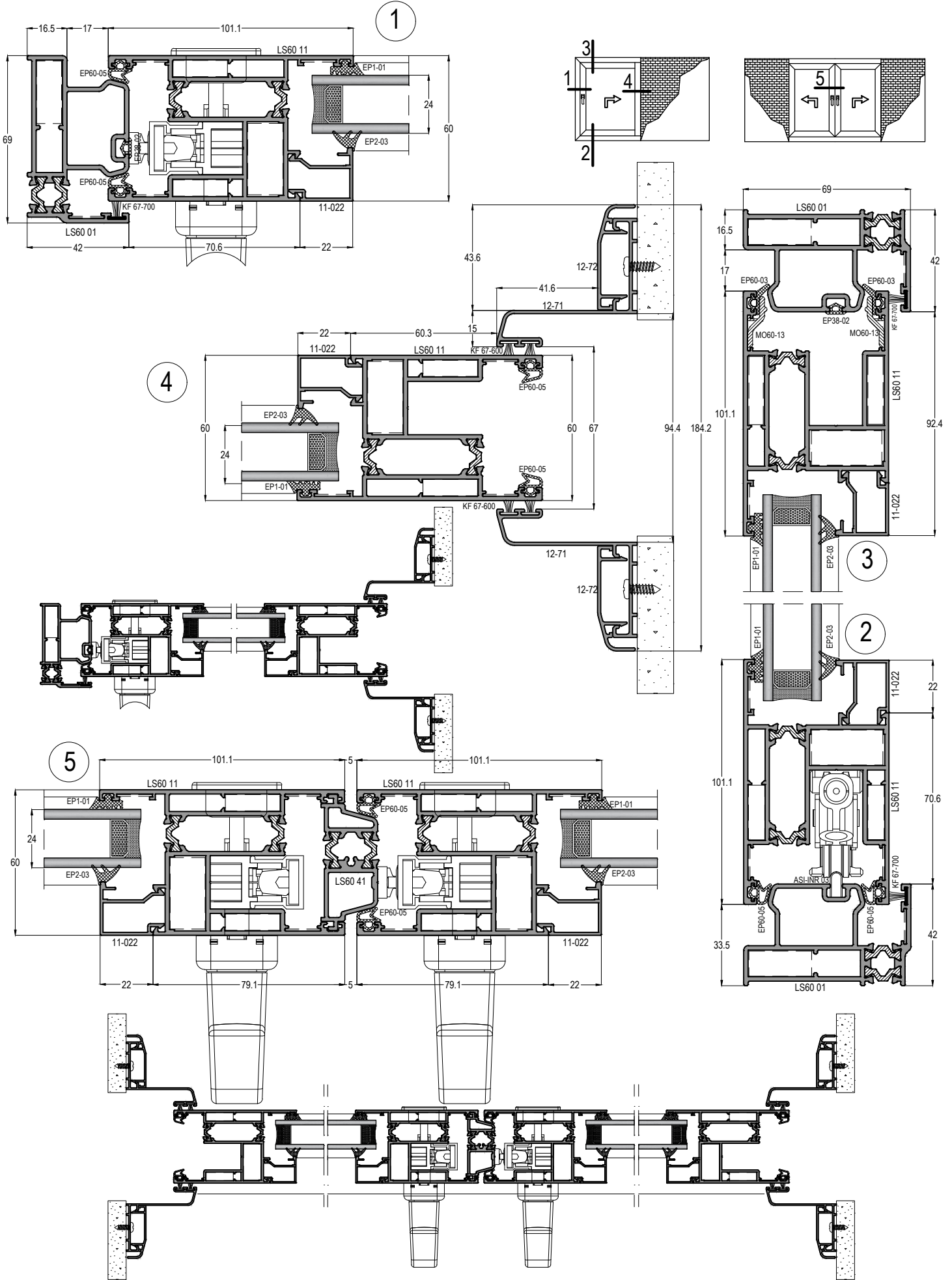

LS60 - 1,8mm

YALITIMLI KALDIR-SÜR SİSTEM
THERMAL LIFT&SLIDE SYSTEM

ASISTAL

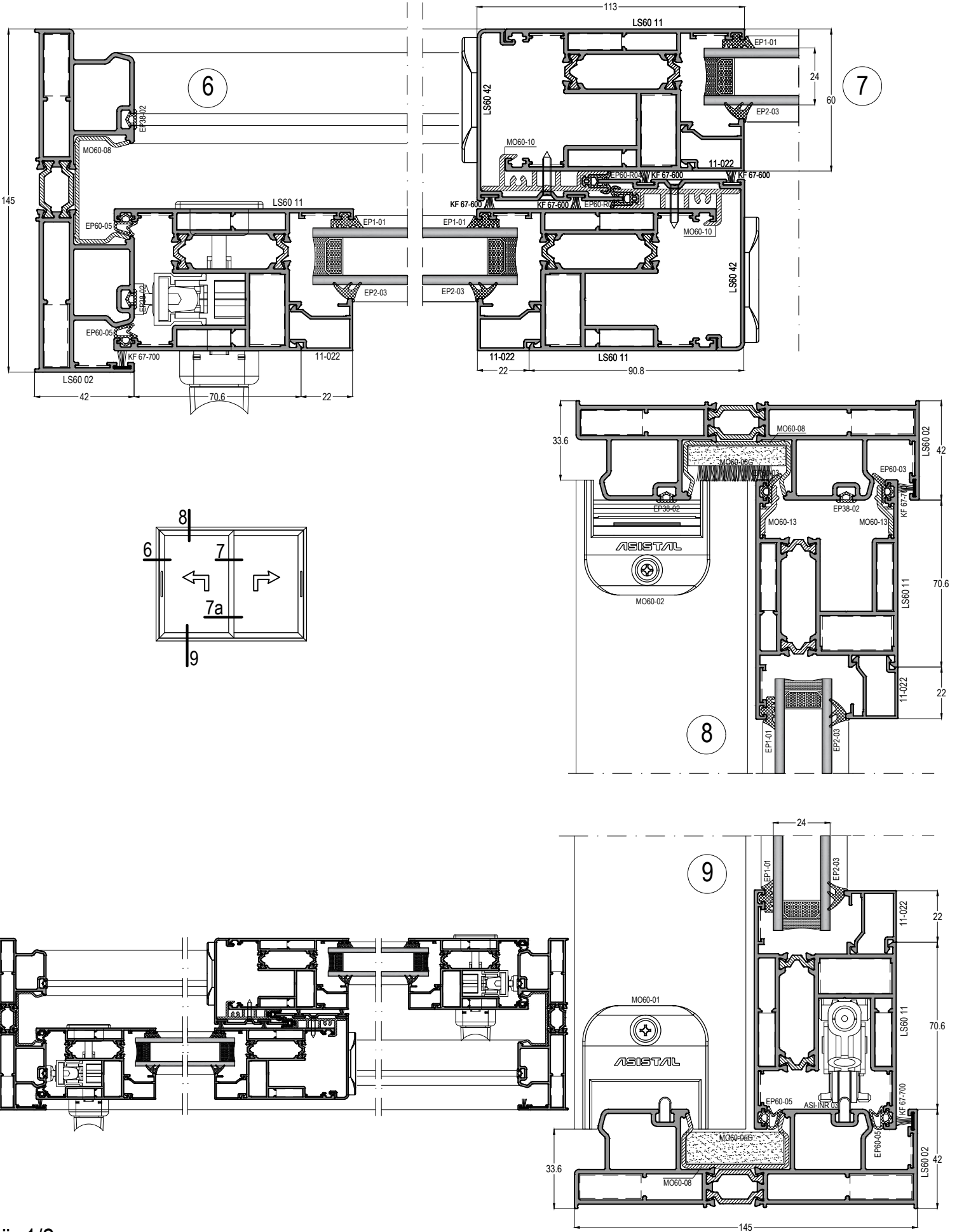

LS60 - 1,8mm

YALITIMLI KALDIR-SÜR SİSTEM
THERMAL LIFT&SLIDE SYSTEM



ORTA KENET KİLİTLEME DETAYLARI CENTRAL LOCKING DETAILS

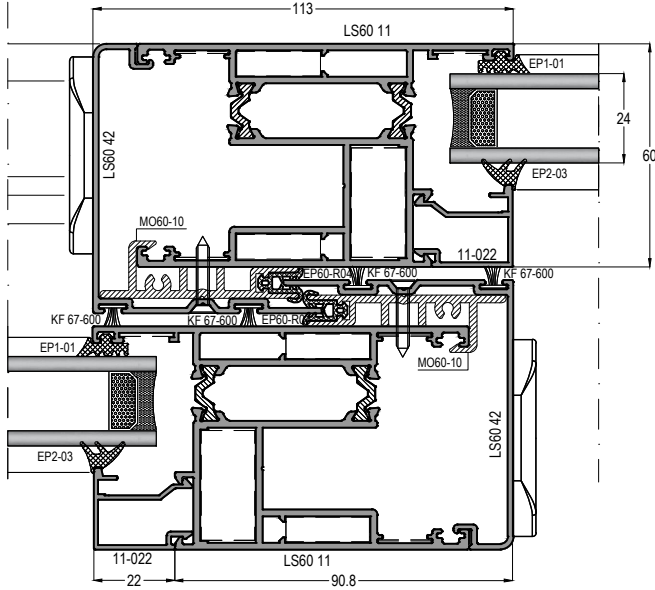

7

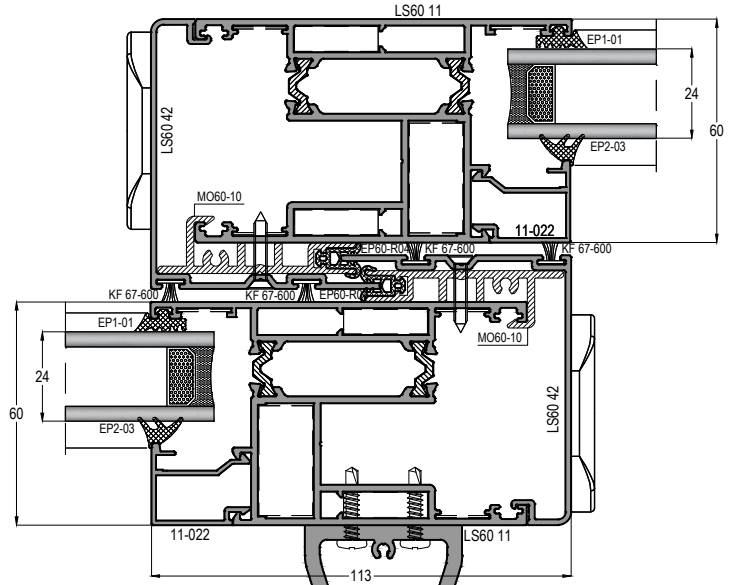

7a

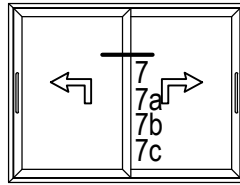

LS60 71

LS60 72

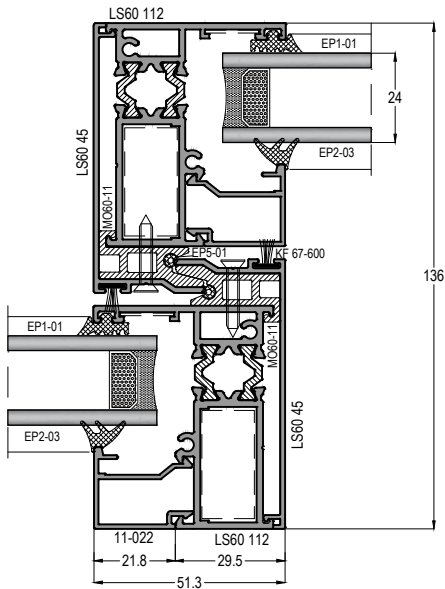

7b

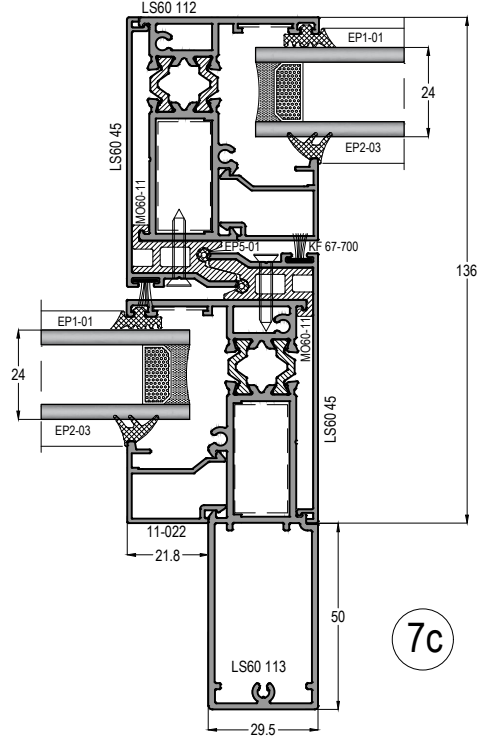

7c

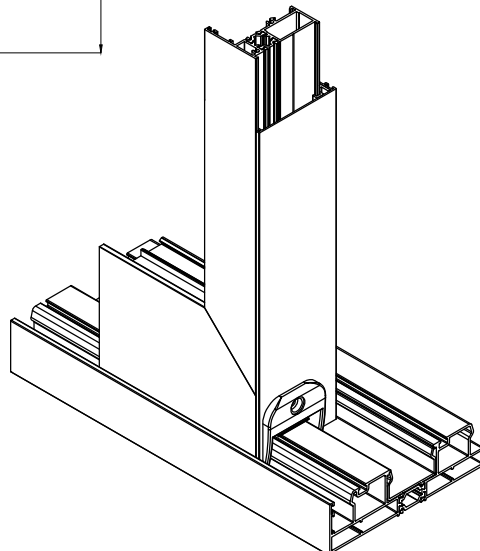

SİNEKLİK DETAYLARI
FLY SCREEN DETAILS

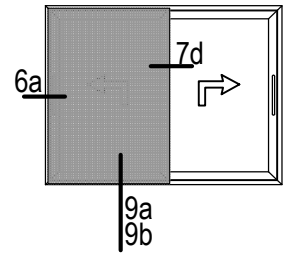
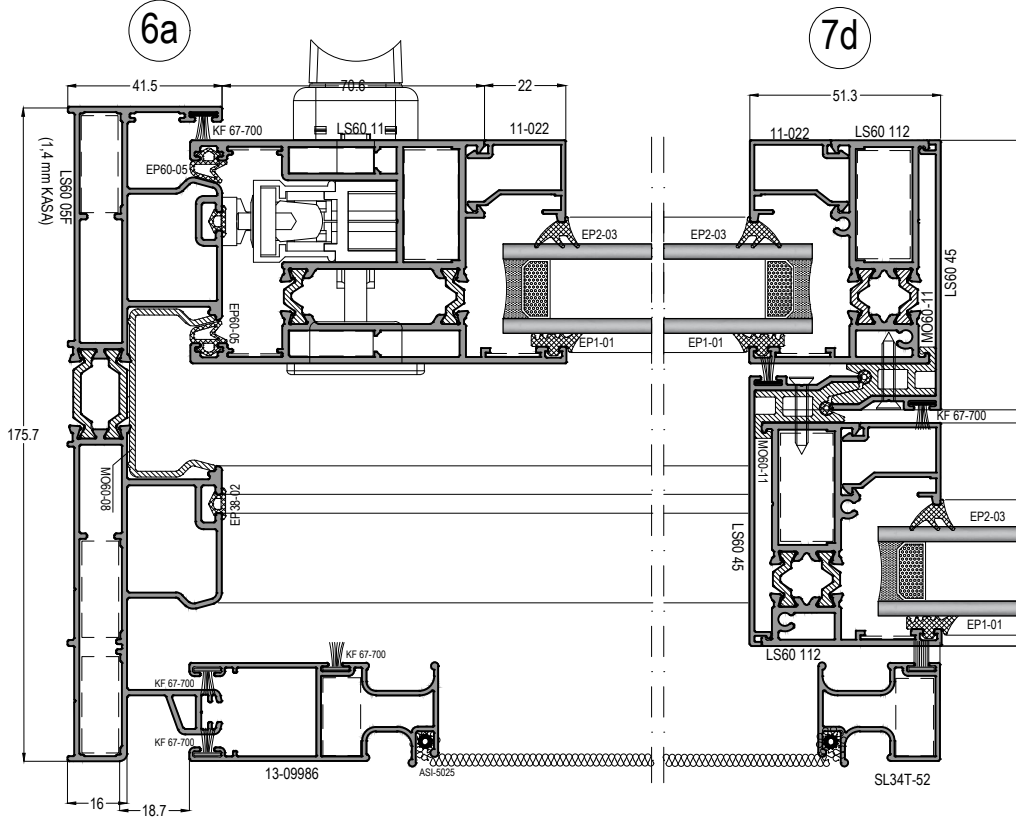
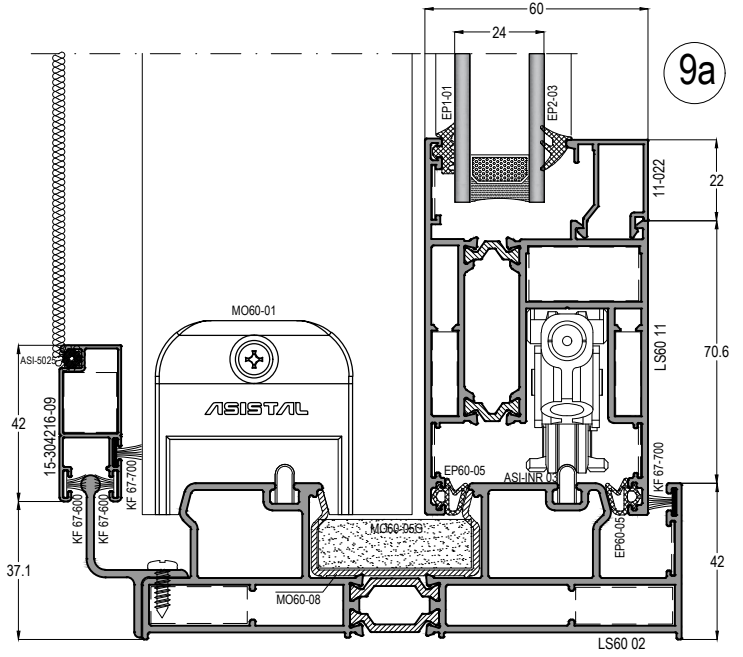
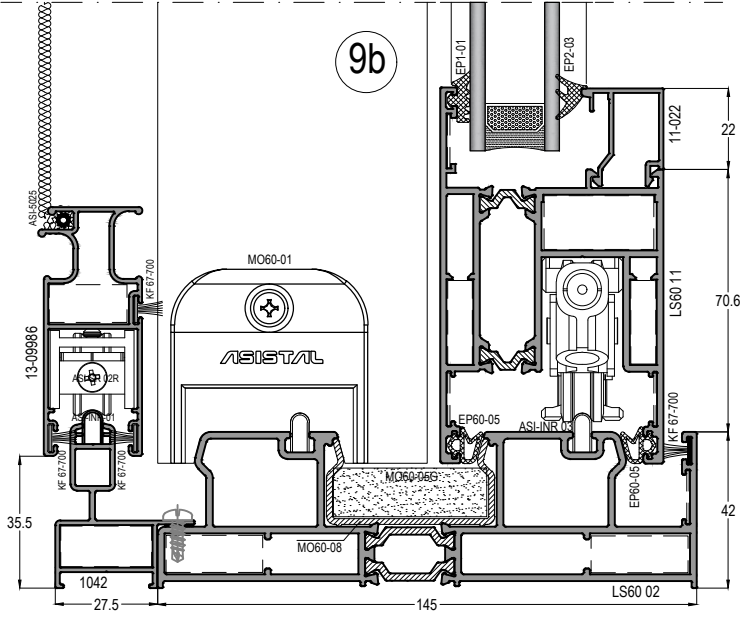

LS60 - 1,8mm

YALITIMLI KALDIR-SÜR SİSTEMİ
THERMAL LIFT&SLIDE SYSTEM

ASISTAL

11

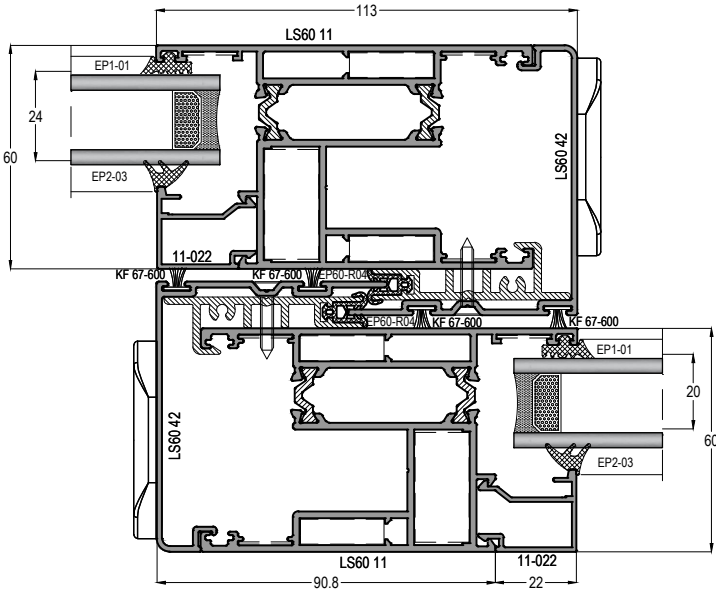

12

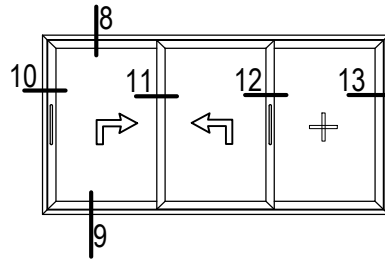
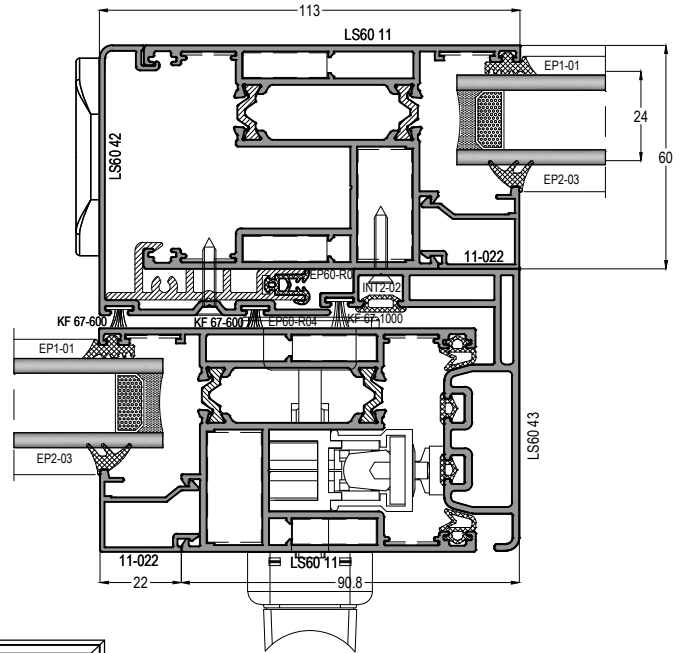

10

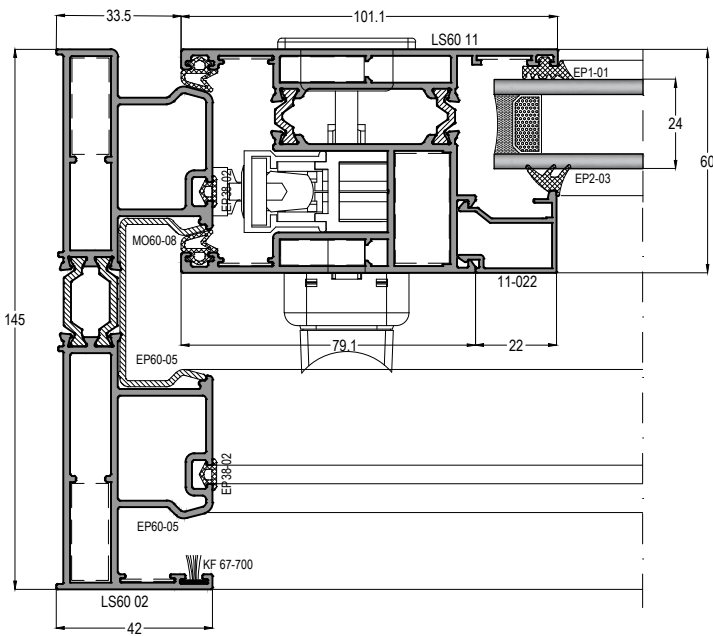

13

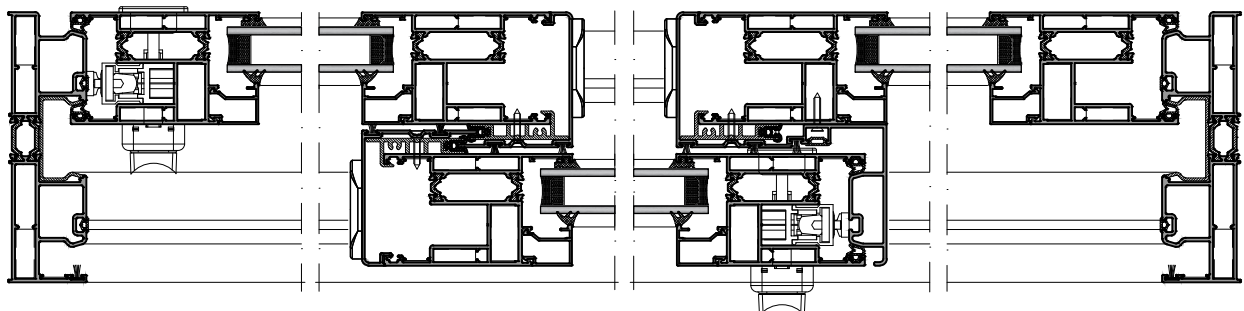
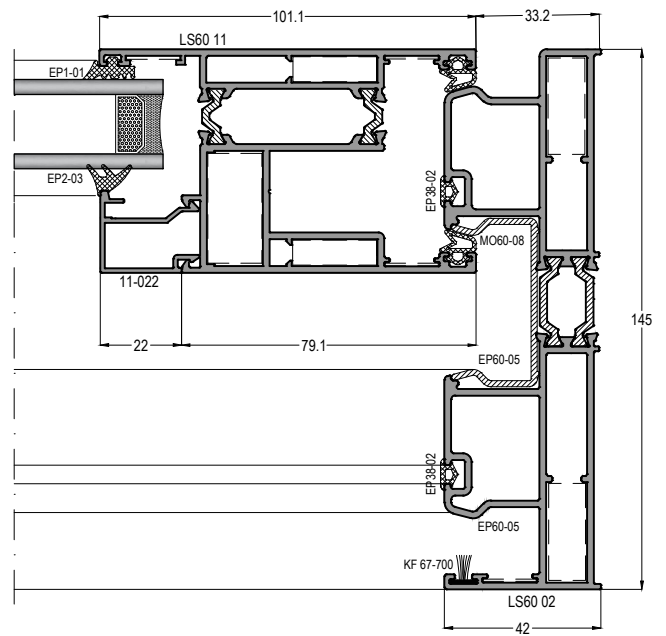

LS60 - 1,8mm

YALITIMLI KALDIR-SÜR SİSTEM
THERMAL LIFT&SLIDE SYSTEM

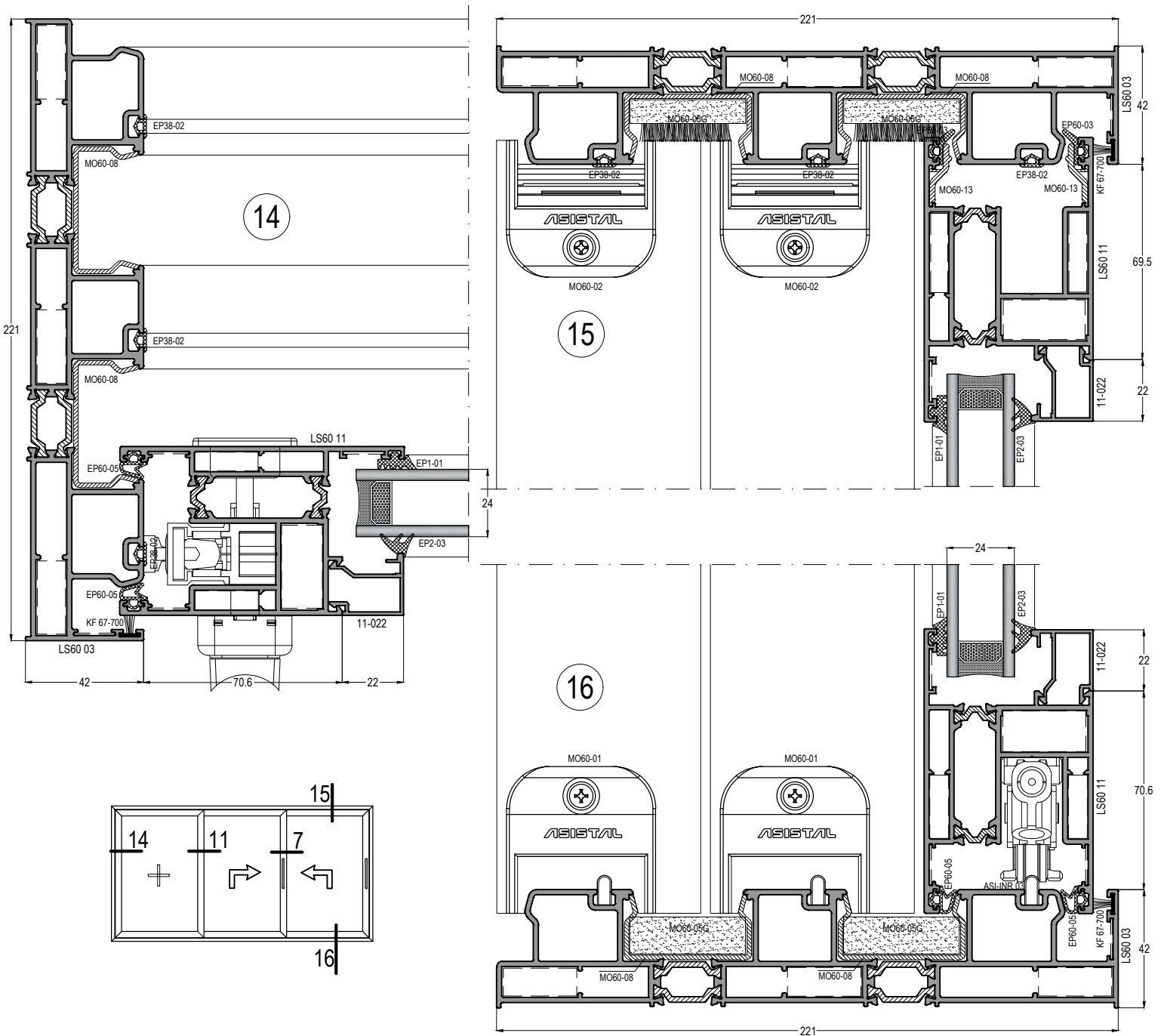

LS60 - 1,8mm

YALITIMLI KALDIR-SÜR SİSTEMİ
THERMAL LIFT&SLIDE SYSTEM



17

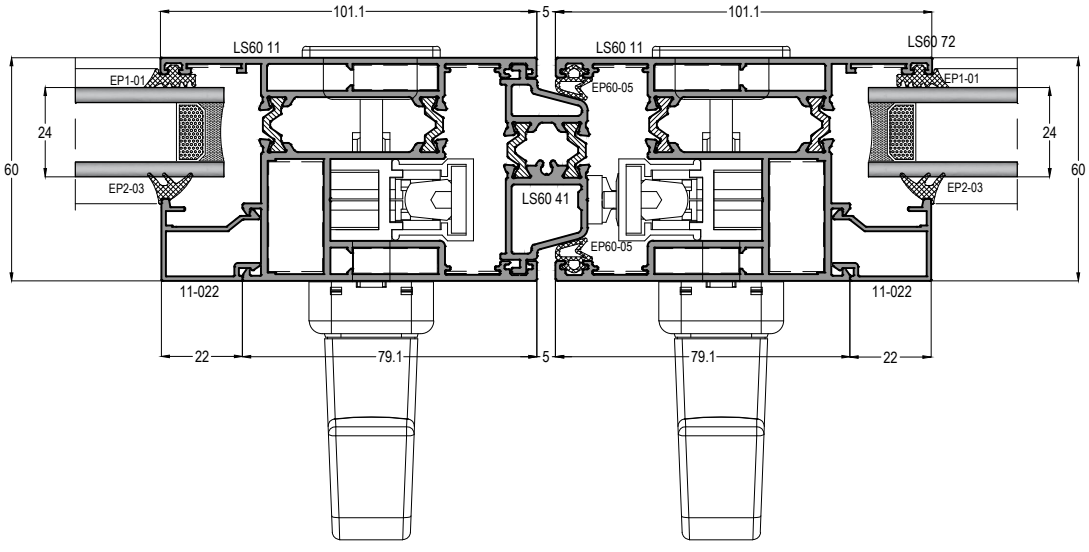

18

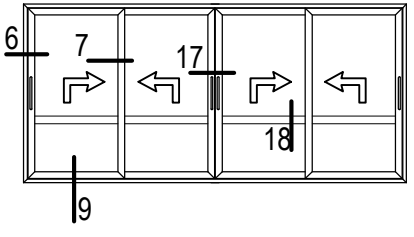
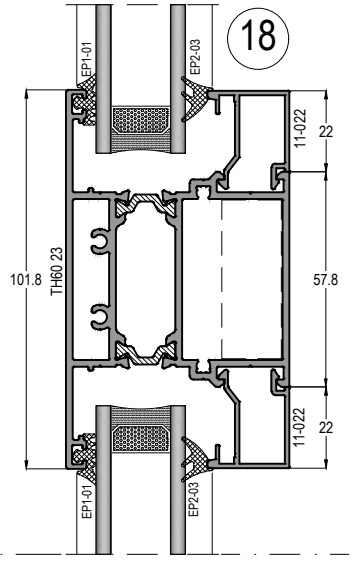

9

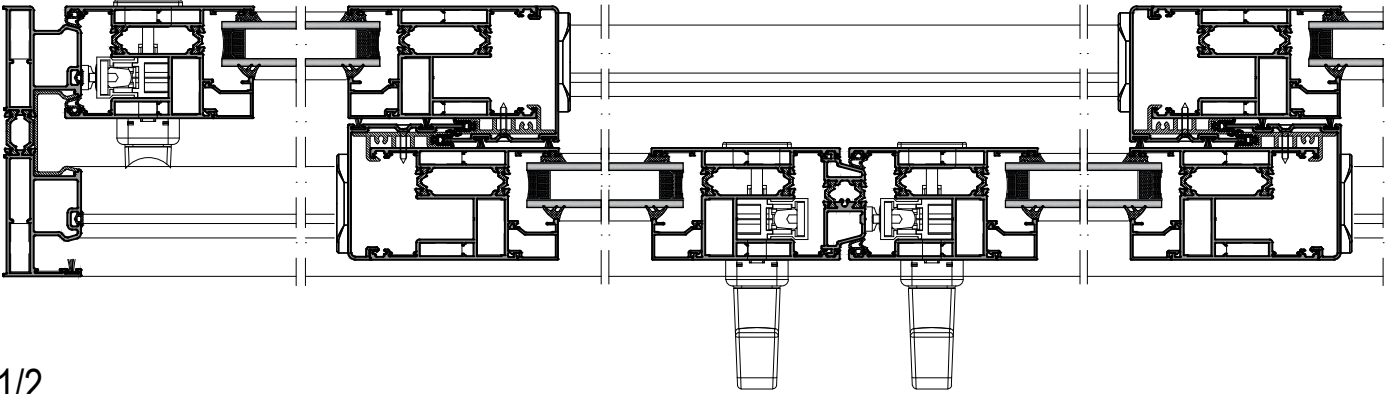
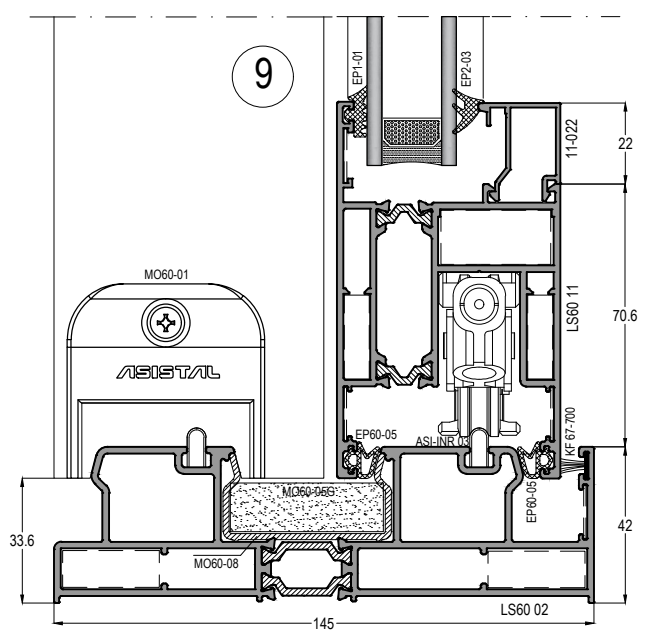



HAREKETLİ KANATDAN SABİT YAPILMASI
SLIDING SASH CONVERTING TO THE FIXED SASH

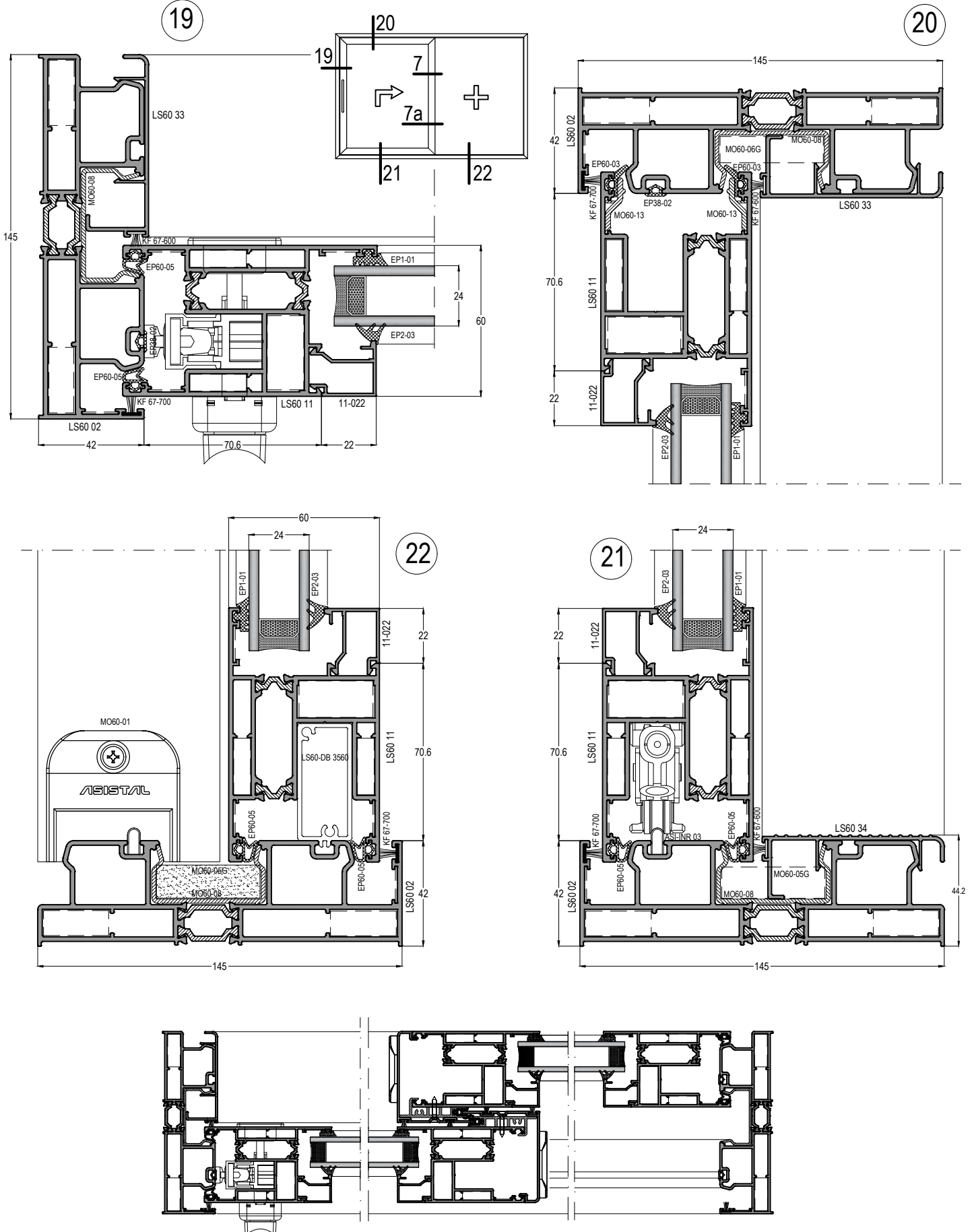

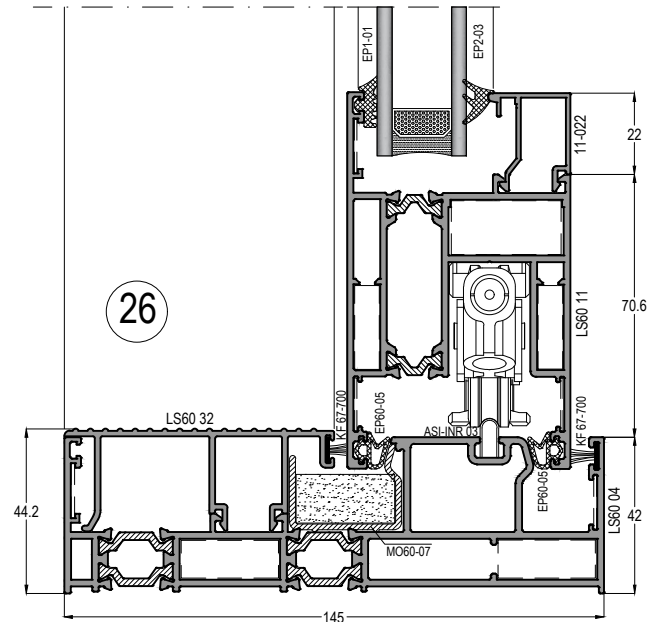
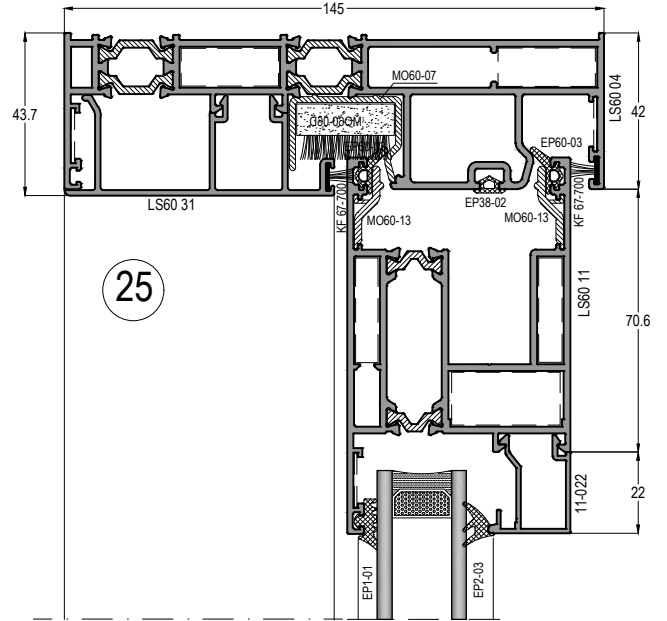
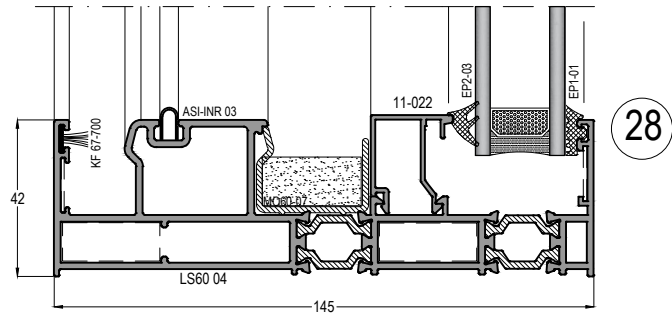
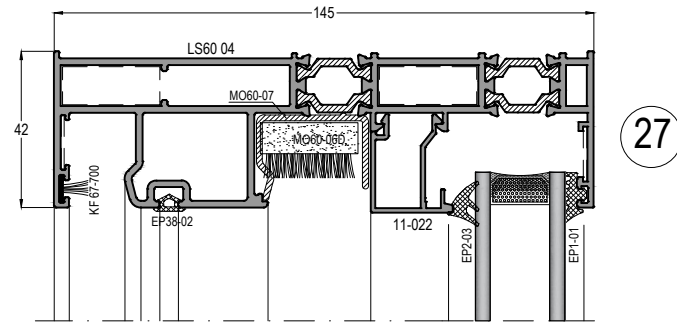
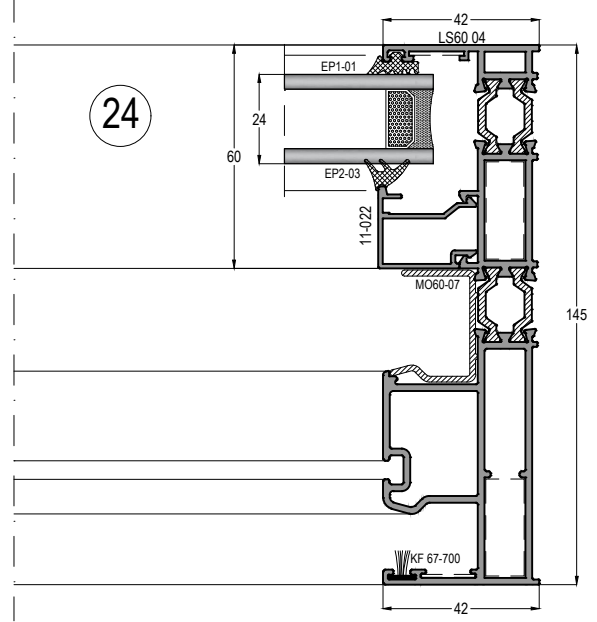
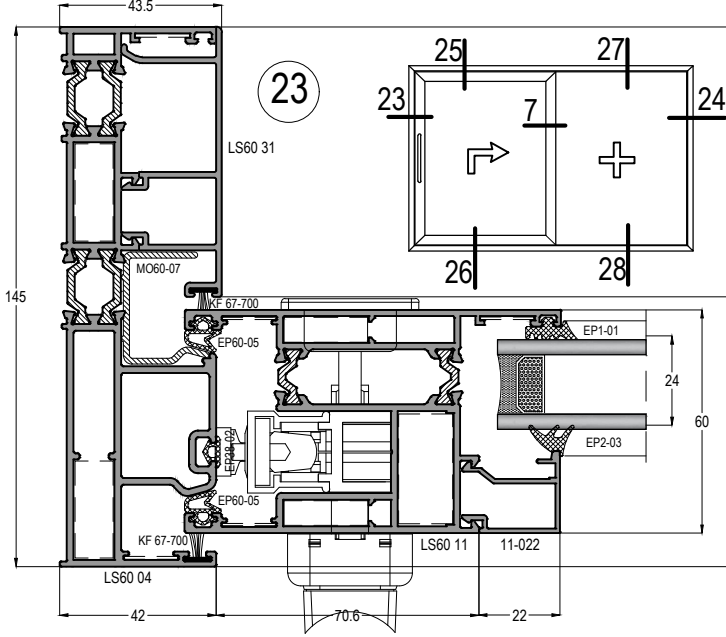
HAREKETLİ KANADI İÇERİDE OLAN MONORAIL SİSTEM
MONORAIL SYSTEM WITH SLIDING SASH INSIDE

NOT: LS60 04 KASA, CAM KALINLIĞI 24mm DEN FAZLA OLAN CAMLARIN MONTAJI İÇİN UYGUN DEĞİLDİR

LS60 04 CASE, NOT SUITABLE FOR INSTALLATION FOR GLASSES WITH GLASS THICKNESS MORE THAN 24mm

HAREKETLİ KANADI DIŞARIDA OLAN MONORAİL SİSTEM
MONORAIL SYSTEM WITH SLIDING SASH OUTSIDE

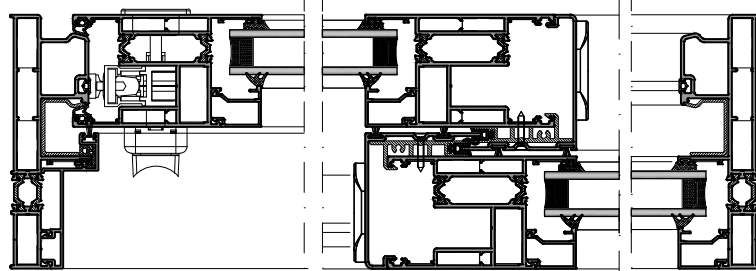
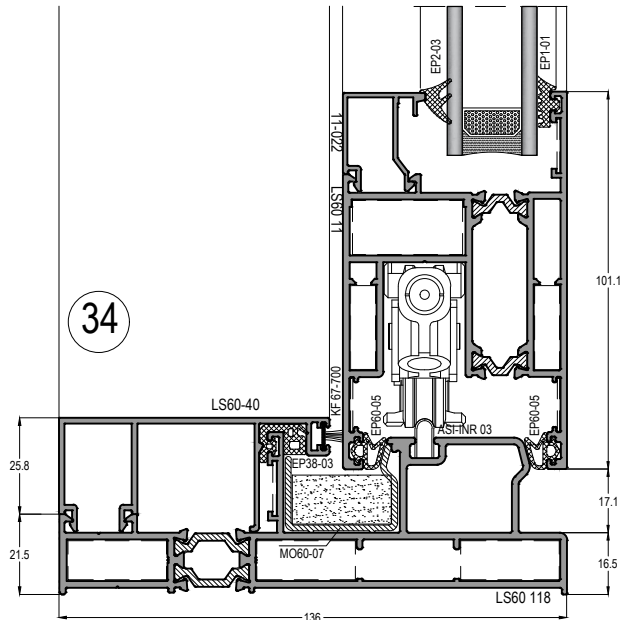
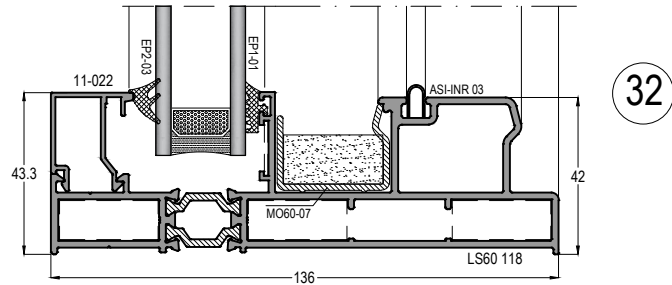
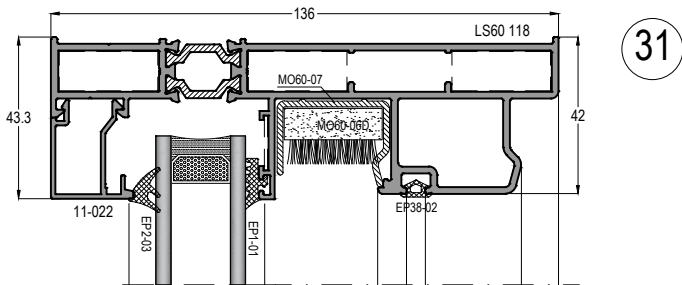
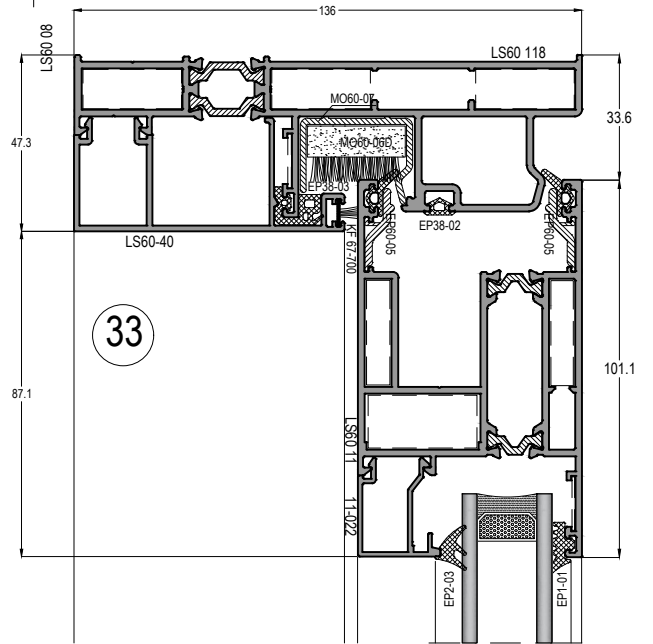
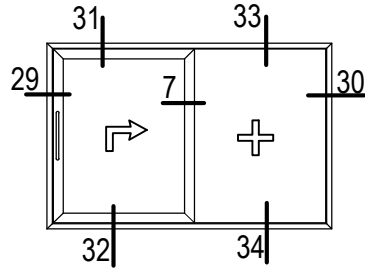
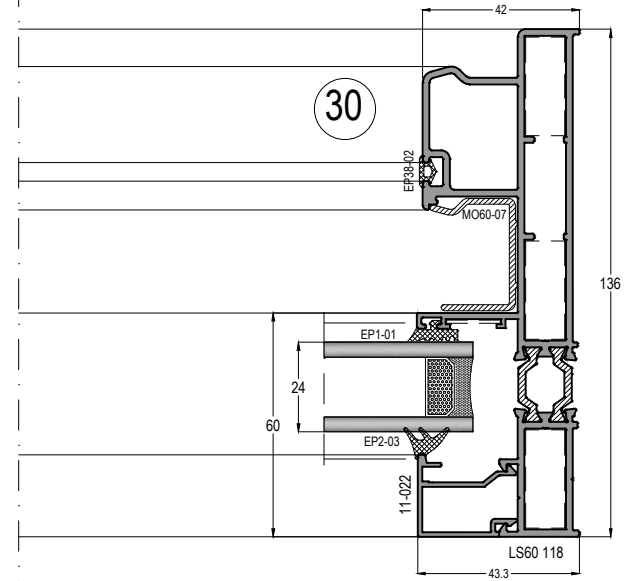
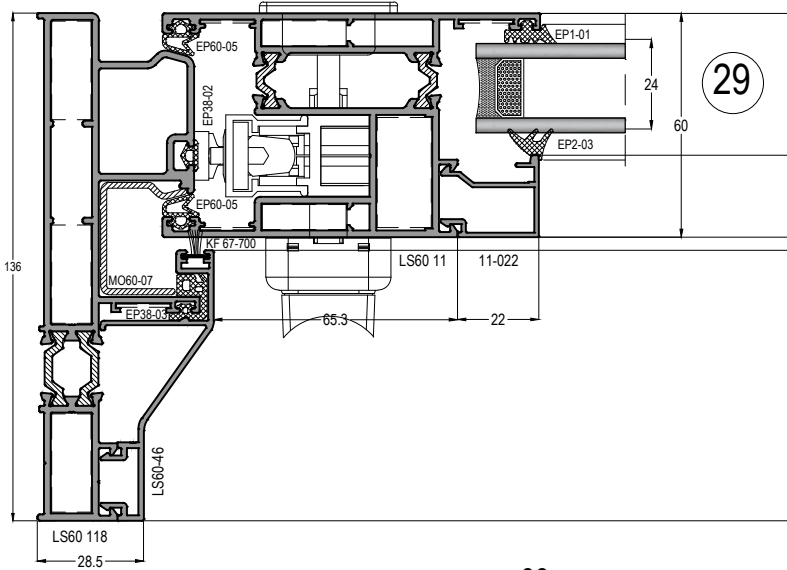

LS60

YALITIMLI KALDIR-SÜR SİSTEM
THERMAL LIFT&SLIDE SYSTEM



HAREKETLİ KANADI DIŞARIDA OLAN MONORAIL SİSTEM DAR KENET
NARROW MONORAIL SYSTEM WITH SLIDING SASH OUTSIDE

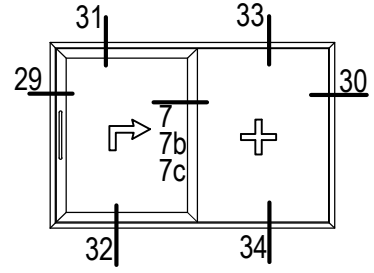

29

7b

30

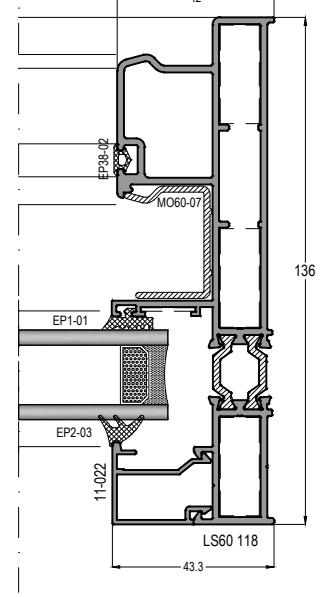
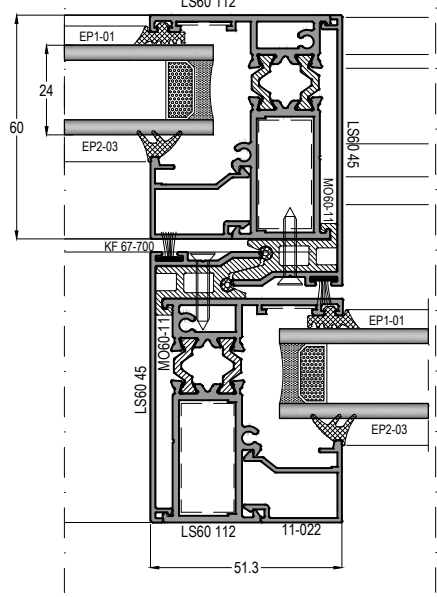
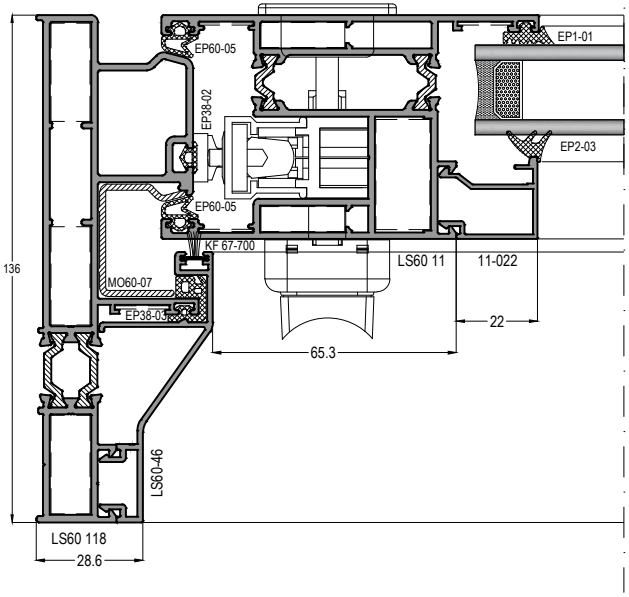

7c

30

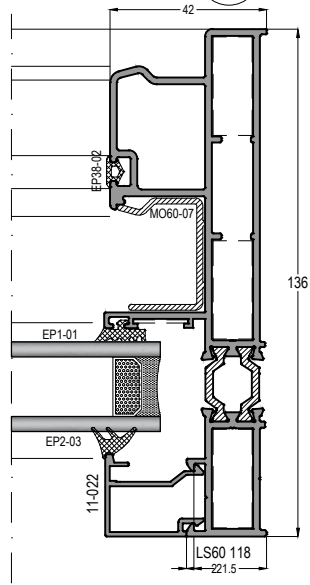
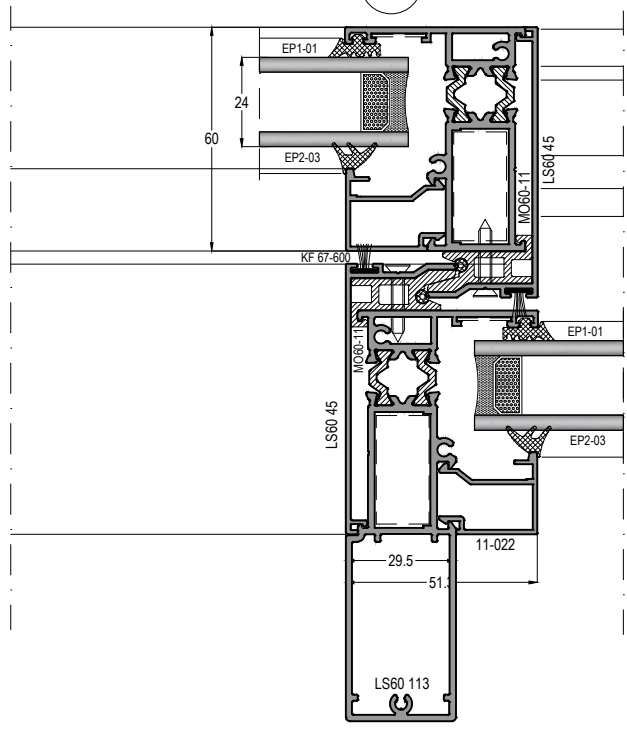

HAREKETLİ KANADI DIŞARIDA OLAN MONORAIL SİSTEM
MONORAIL SYSTEM WITH SLIDING SASH OUTSIDE

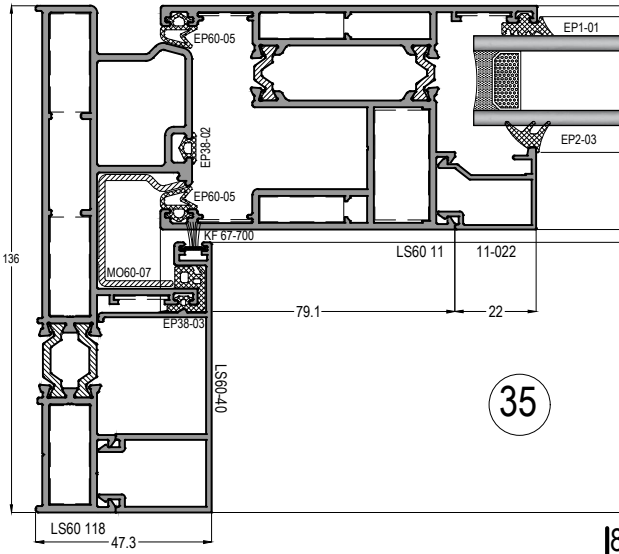

35

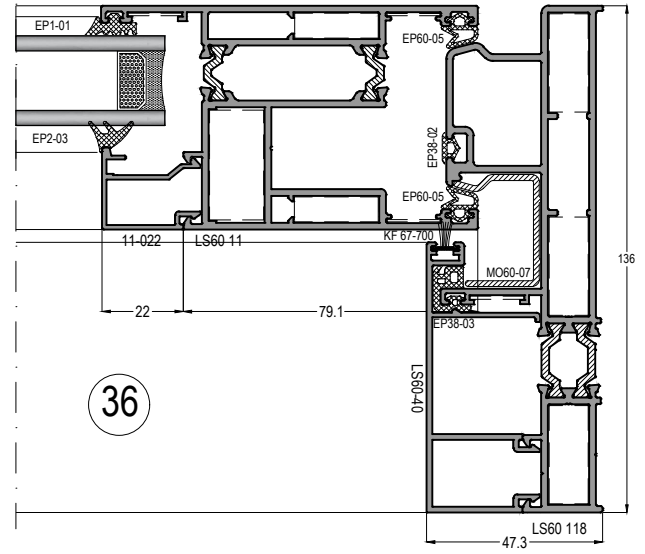

36

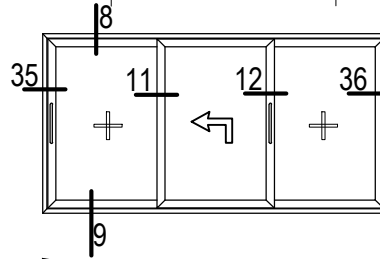

11

12

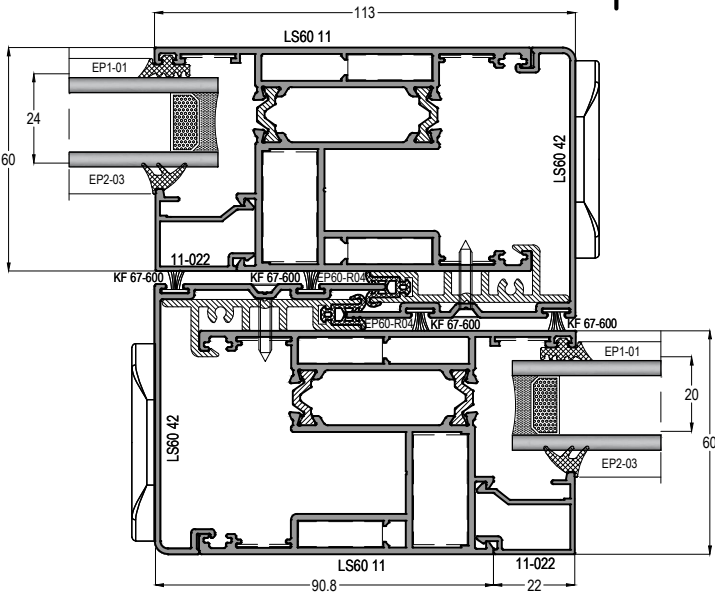

11

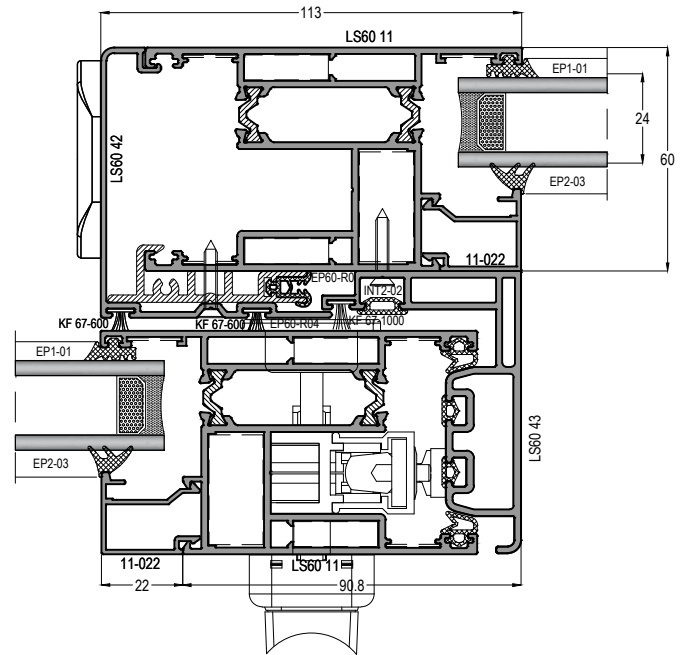

12

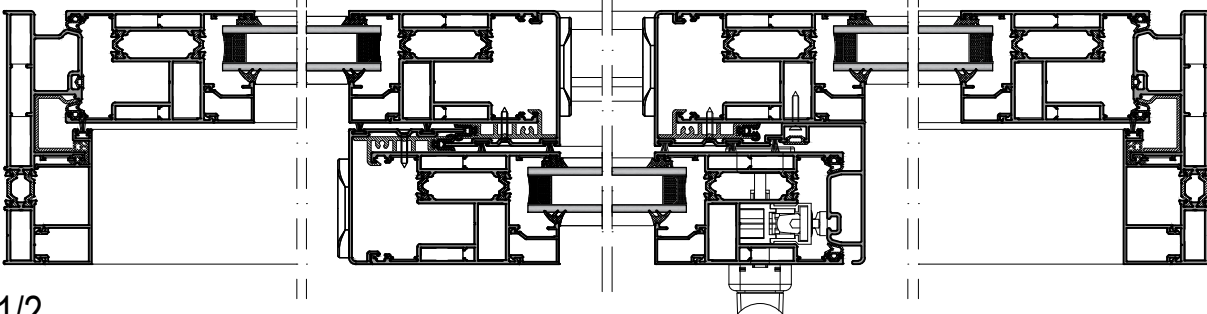

TH62 SİSTEME GEÇİŞ KASASI
TRANSITION FRAME TO TH62 SYSTEM

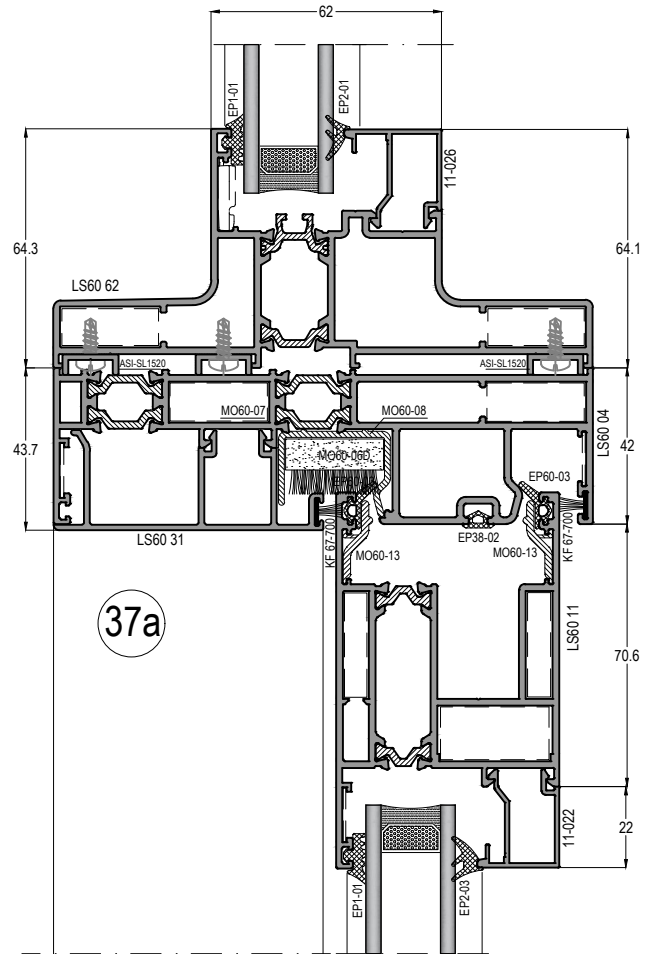
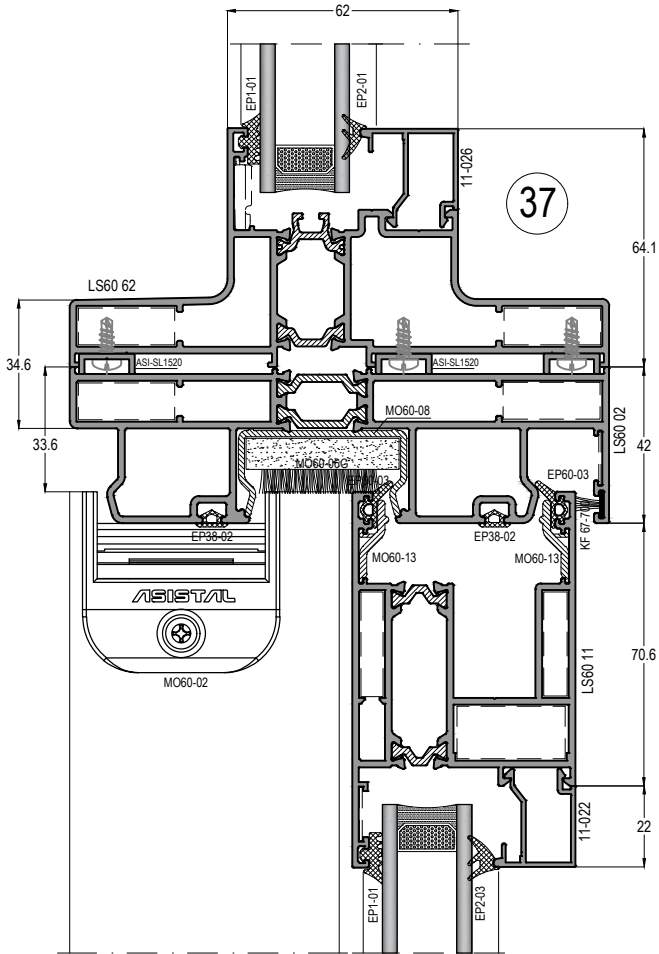
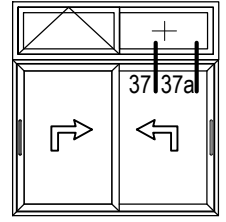



NORMAL SÜRME SİSTEM DETAYI - LS60 N
NORMAL SLIDING SYSTEM DETAILS

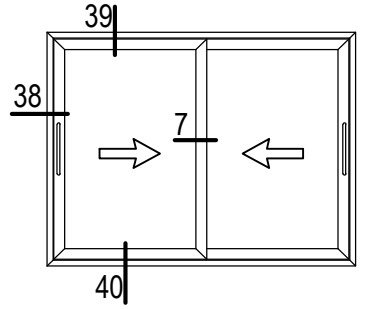

38

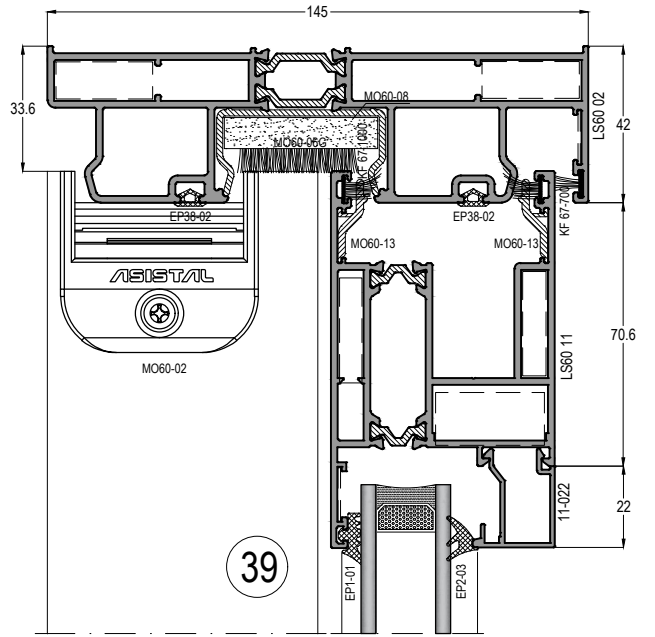
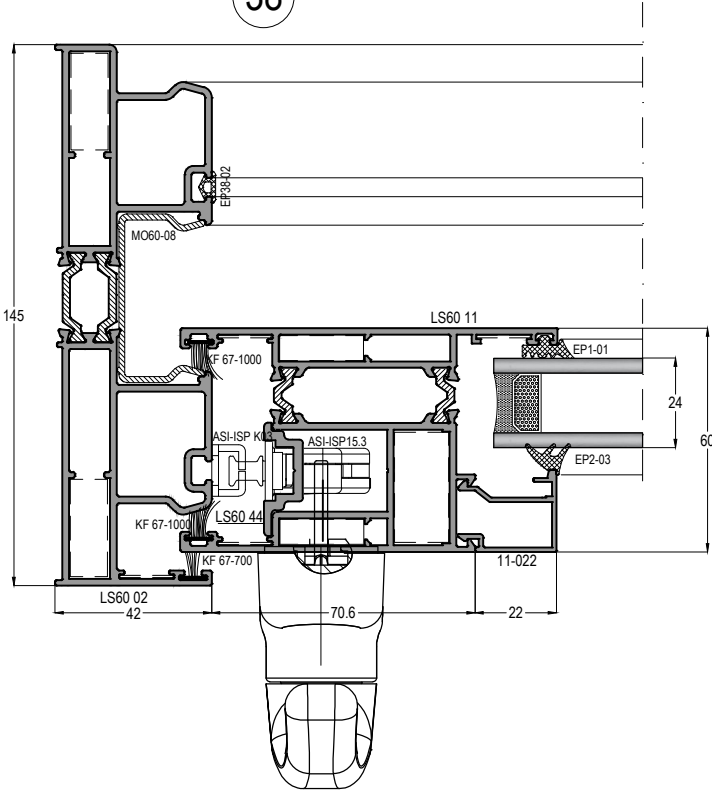

39

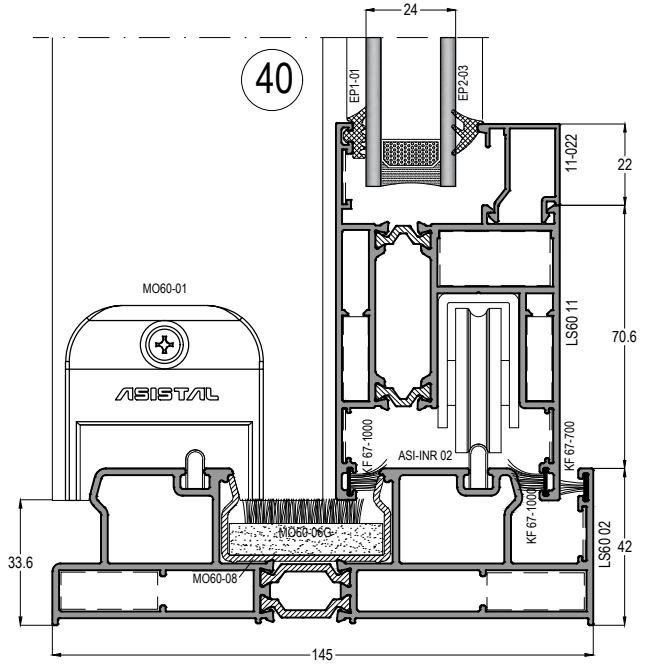

40

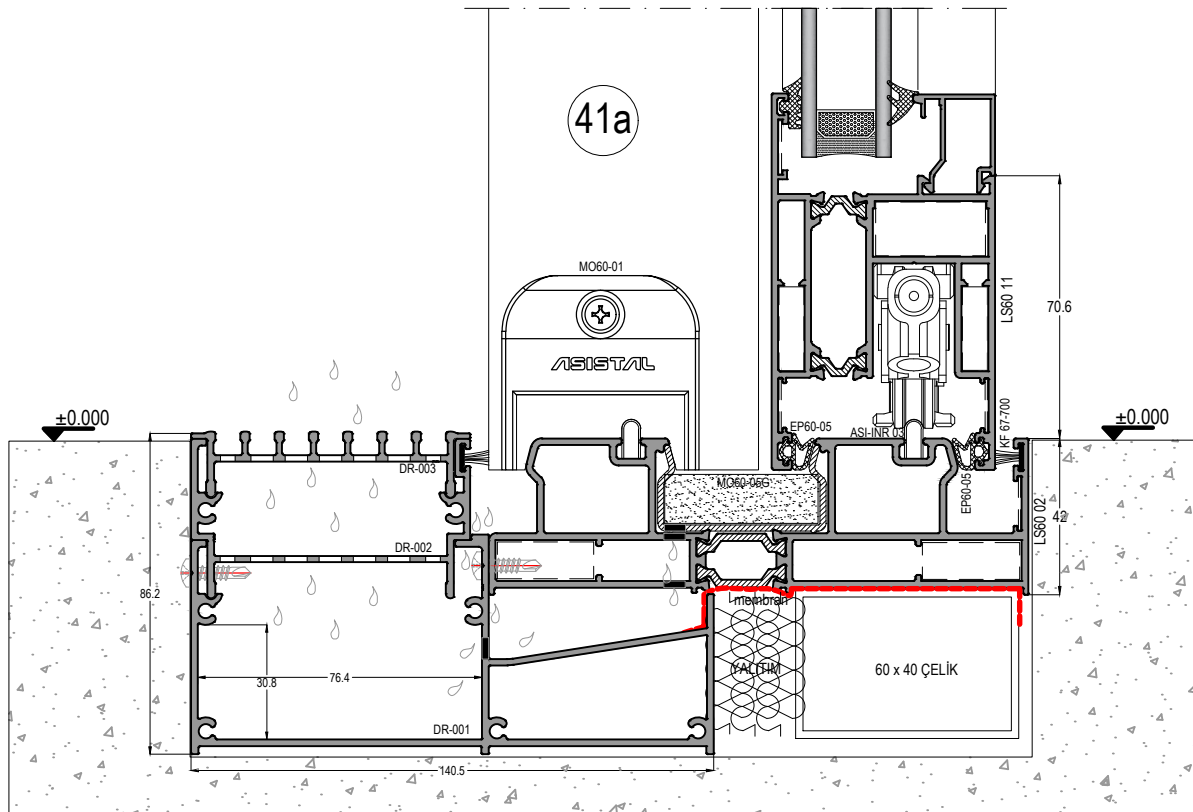
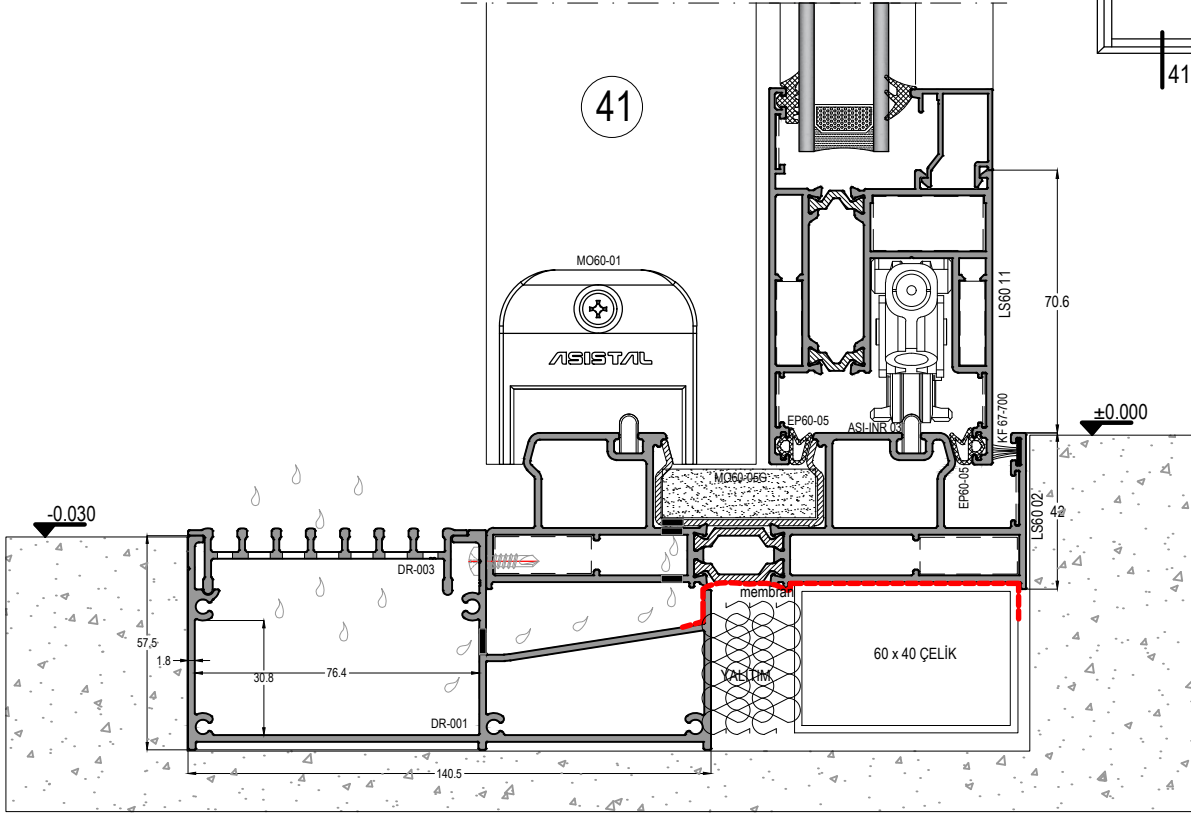
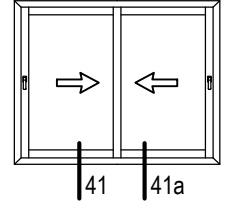
YAĞMUR SUYU TAHLİYE DETAYLARI / DRENAJ
RAIN WATER DRAINAGE DETAILS

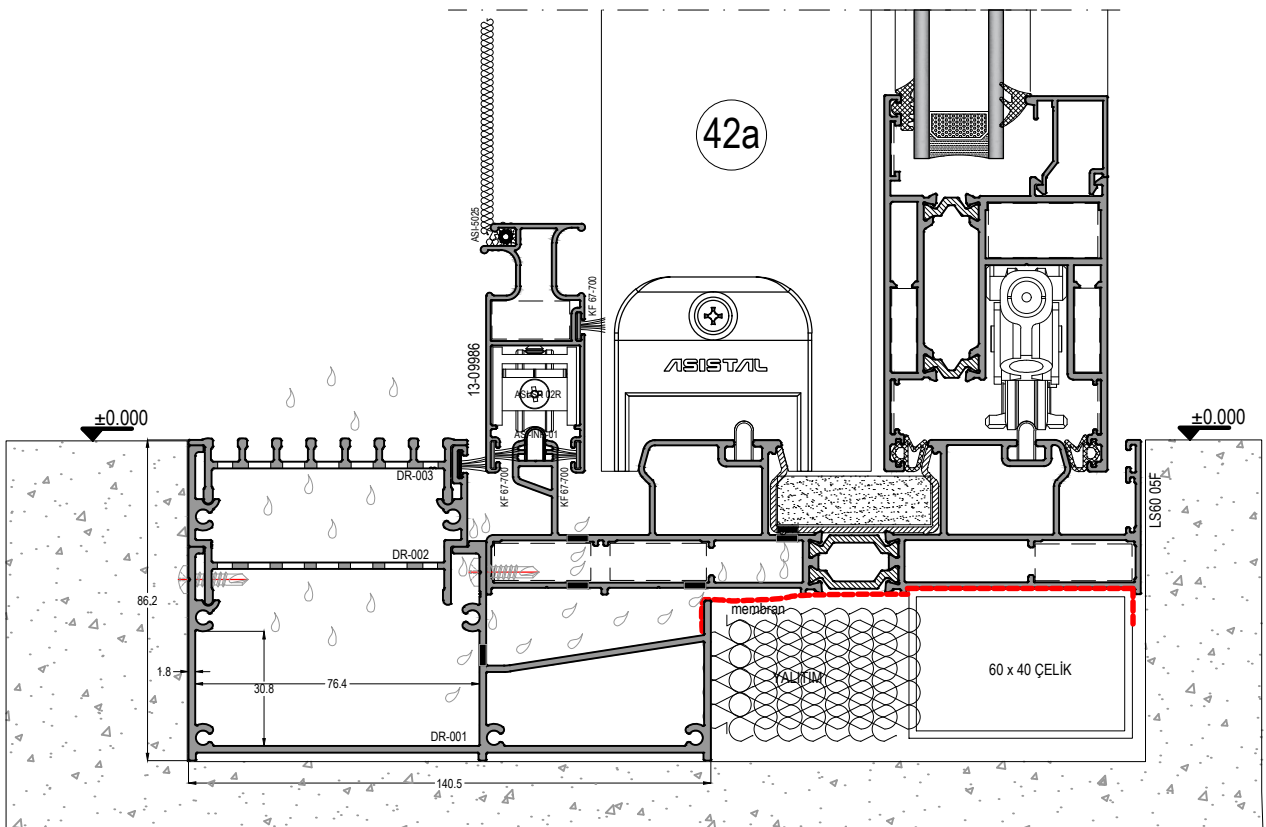
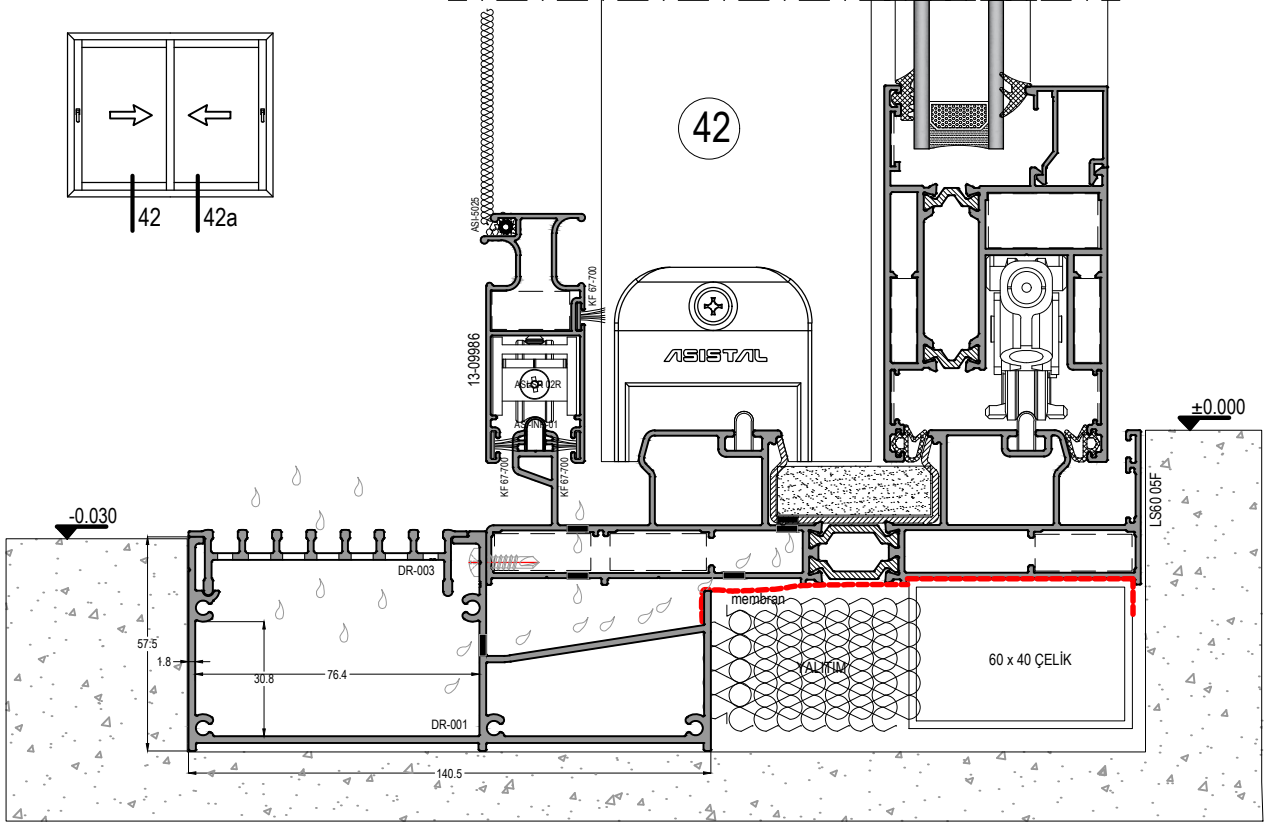
YAĞMUR SUYU TAHLİYE DETAYLARI / DRENAJ
RAIN WATER DRAINAGE DETAILS

YAĞMUR SUYU TAHLİYE DETAYLARI / DRENAJ
RAIN WATER DRAINAGE DETAILS