

SL38T - K

YALITIMLI KALDIR-SÜR SİSTEM
THERMAL LIFT&SLIDE SYSTEM

ASISTAL

KESİM ve MONTAJ
CUTTING & ASSEMBLY

SL38T-K

YALITIMLI KALDIR-SÜR SİSTEM
THERMAL LIFT&SLIDE SYSTEM

ASISTAL

KANAT 45° KÖŞE BİRLEŞİM DETAYLARI DETAILS FOR 45° SASH CORNER JOINT.

501 EKO PANÇ

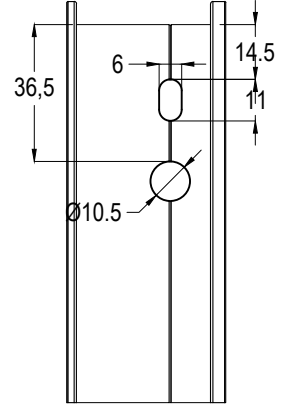
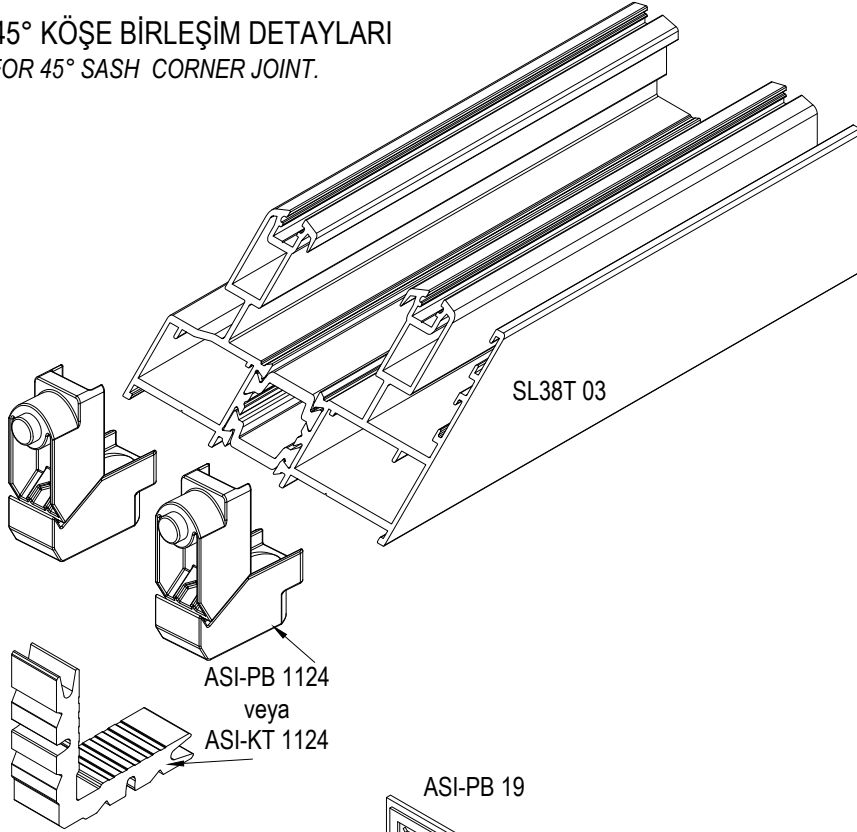
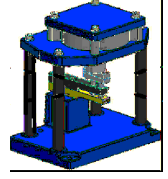

ASI-PB 19

ASI-CC 1220

KÖŞE BAĞLANTI İÇİN 7 veya 8mm ÇAPINDA
TAM ORTA NOKTADAN DELİK AÇILMALIDIR.
FOR CORNER CONNECTION, 7 or 8mm
DIAMETER HOLE SHOULD BE DRILLED
FROM THE MIDDLE POINT.

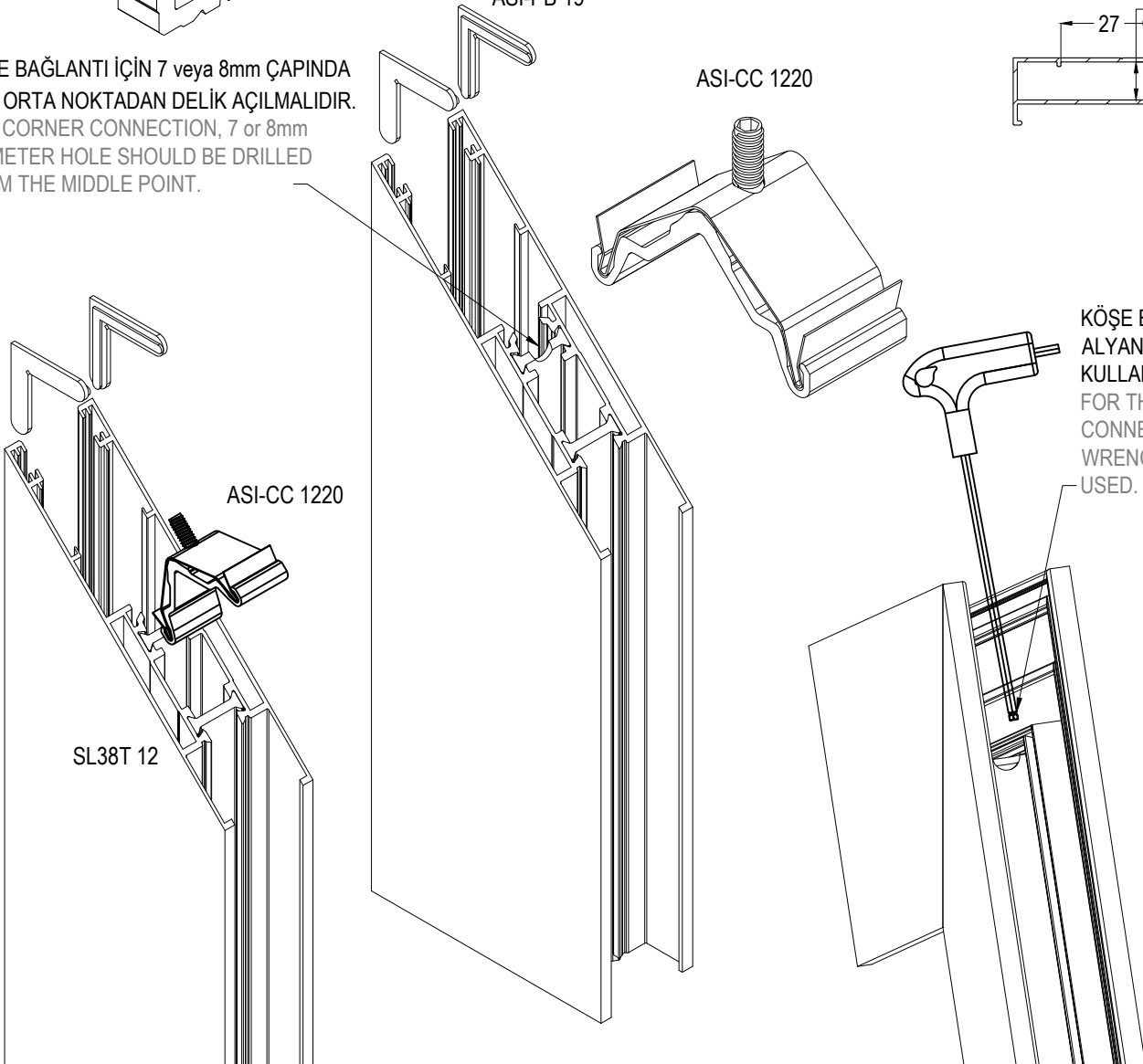
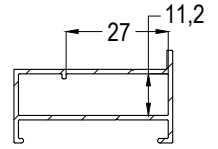

KÖŞE BAĞLANTI İÇİN
ALYAN ANAHTARI
KULLANILACAKTIR.
FOR THE CORNER
CONNECTION ALLEN
WRENCH SHOULD BE
USED.

SL38T 12

ASI-CC 1220

SL38T-K

YALITIMLI KALDIR-SÜR SİSTEM
THERMAL LIFT&SLIDE SYSTEM

ASISTAL

SL38T EKO PANÇ SL38T ECO PUNCH MACHINE

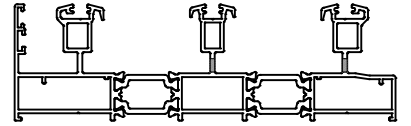
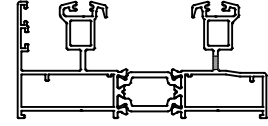
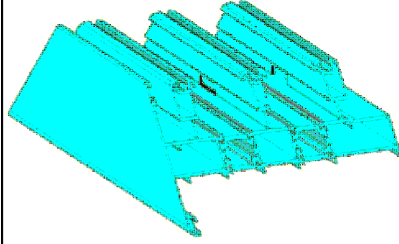
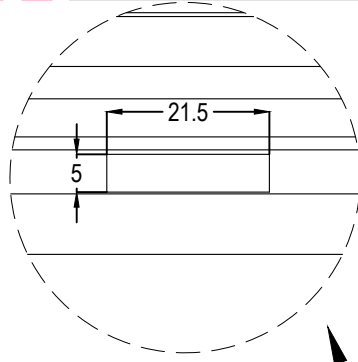

SU TAHLİYE DELİĞİ

Water Drainage

SL38T 09

SL38T 10

SL38T 101

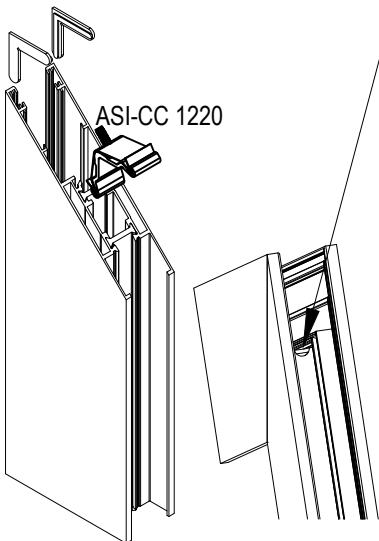
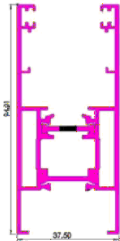
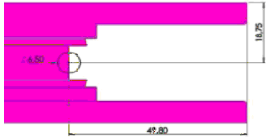
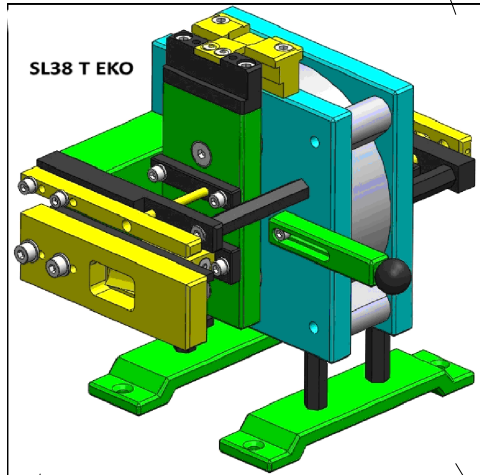

ASI-CC 1220 KÖŞE BAĞLANTI

İÇİN DELME İŞLEMİ

Drill For Corner Joint

SL38T 12

SL38T 16

SL38T 17

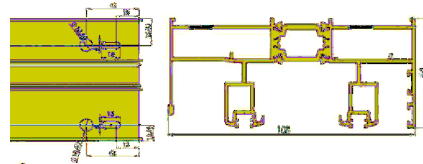
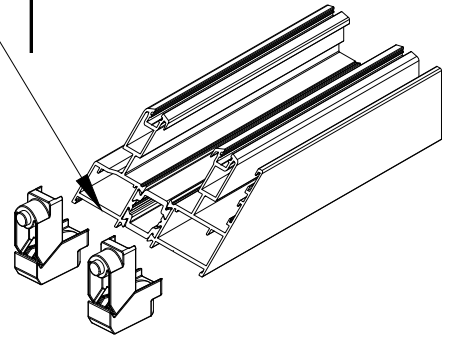

ASI-PB 1124 PİMLİ KÖŞE BAĞLANTI

İÇİN KASA DELME İŞLEMİ

Drill For Button Corner Joint

SL38T 09

SL38T 10

SL38T 101

ASI-STP 06 KANAT STOPER VE KANAT DENGELİYİCİ ASI-STP 06 SASH STOPER AND SASH STABILIZATION SPACER

ASI-STP 06

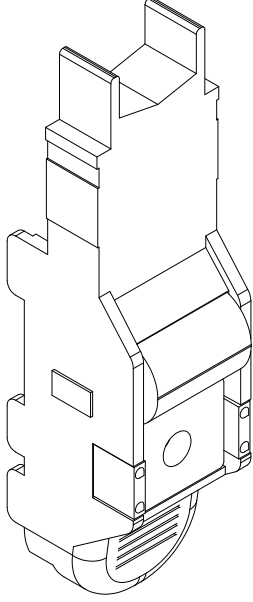

ASI-STP 06

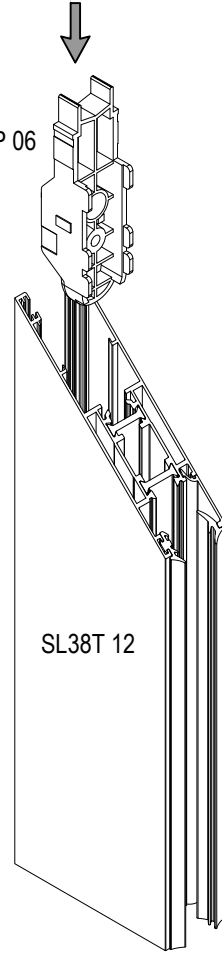

ASI-STP 06

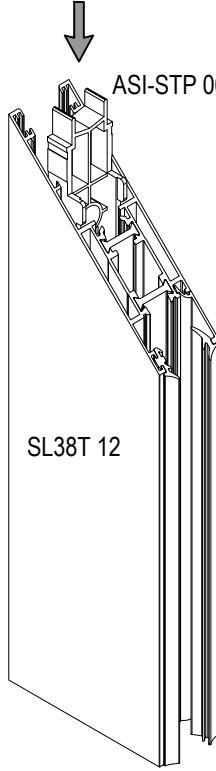

SL38T 12

SL38T 12

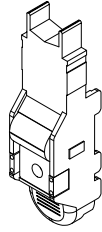

ASI-STP 06



ASI-STP 06

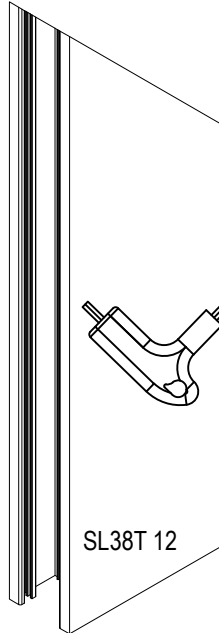

SL38T 12

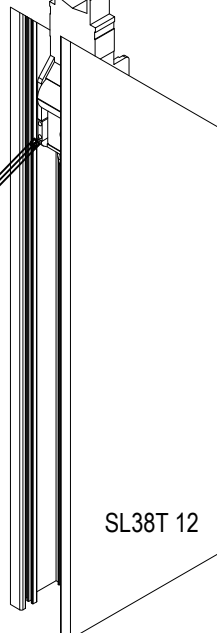

SL38T 12

DÜZ KESİM İÇİN KENET KAPAĞI FLAT CUTTING INTERLOCK PROFILE CAP

- KANAT AÇILIŞ YÖNÜNE GÖRE SAĞ VEYA SOL KAPAK OLARAK KULLANILACAKTIR.
COVERS WILL BE USED RIGHT OR LEFT, ACCORDING TO THE SASH SLIDING DIRECTION

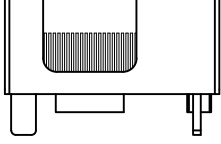

SL38T-KP 04

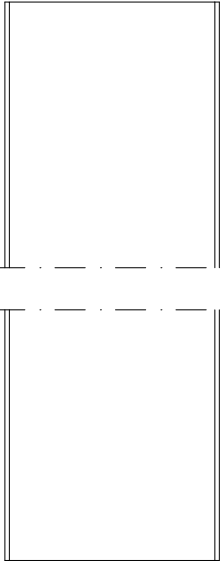

SL38T 42

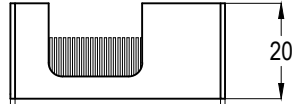

20

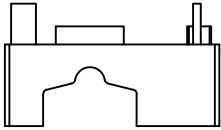

SL38T-KP 05

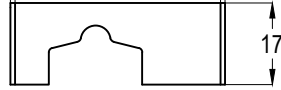

17

SL38T-KP 04

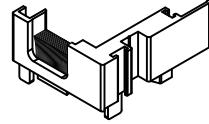

H-37mm

SL38T 42

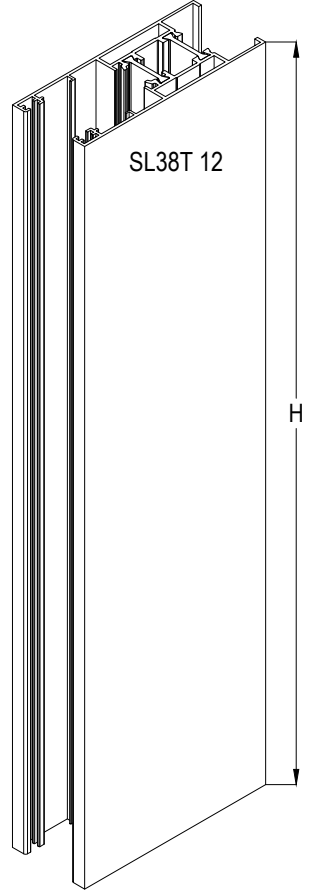

SL38T 12

H

SL38T 42 kesim ölçüsü: Kanat yüksekliği - 37mm
SL38T 42 cutting size : Sash height - 37mm

SL38T-KP 04

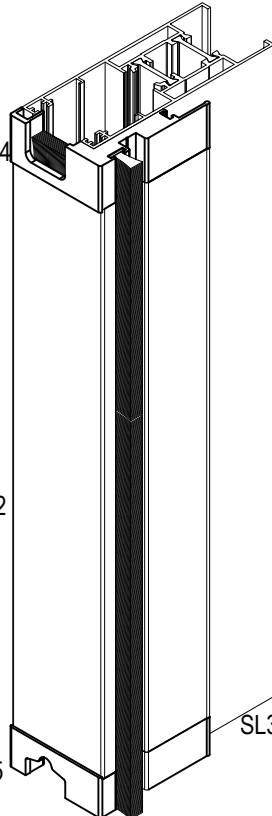

SL38T 42

SL38T-KP 05

SL38T 12

KF 67-550

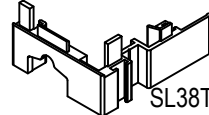

SL38T-KP 05

KF 67-550 FITİLLERİ
KANAT BOYU KADAR UZUN
OLMALI
KF 67-550 must be
as long as sash profile height.

DÜZ KESİM İÇİN KENET KAPAĞI

FLAT CUTTING INTERLOCK PROFILE CAP

- KANAT AÇILIŞ YÖNÜNE GÖRE SAĞ VEYA SOL KAPAK OLARAK KULLANILACAKTIR.
COVERS WILL BE USED RIGHT OR LEFT, ACCORDING TO THE SASH SLIDING DIRECTION

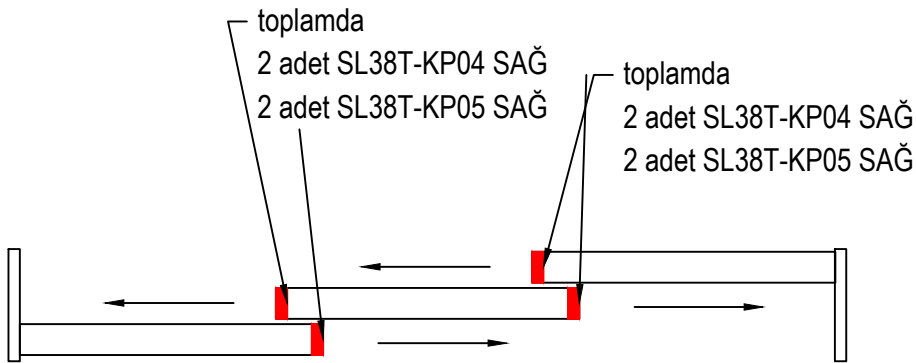
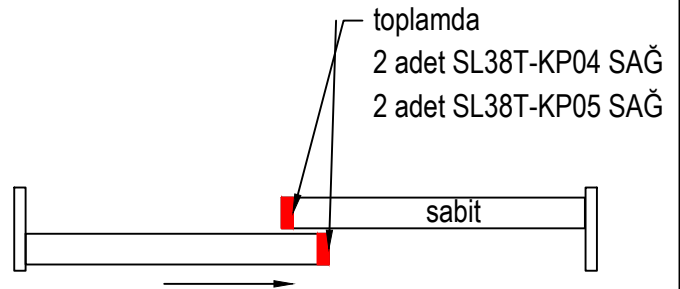
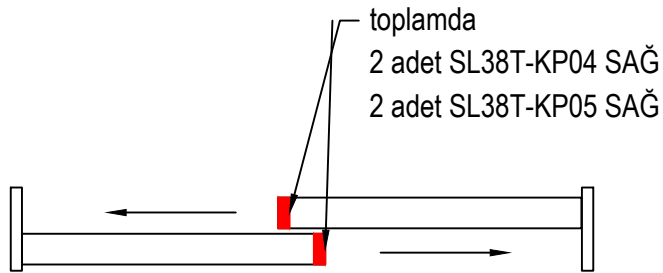
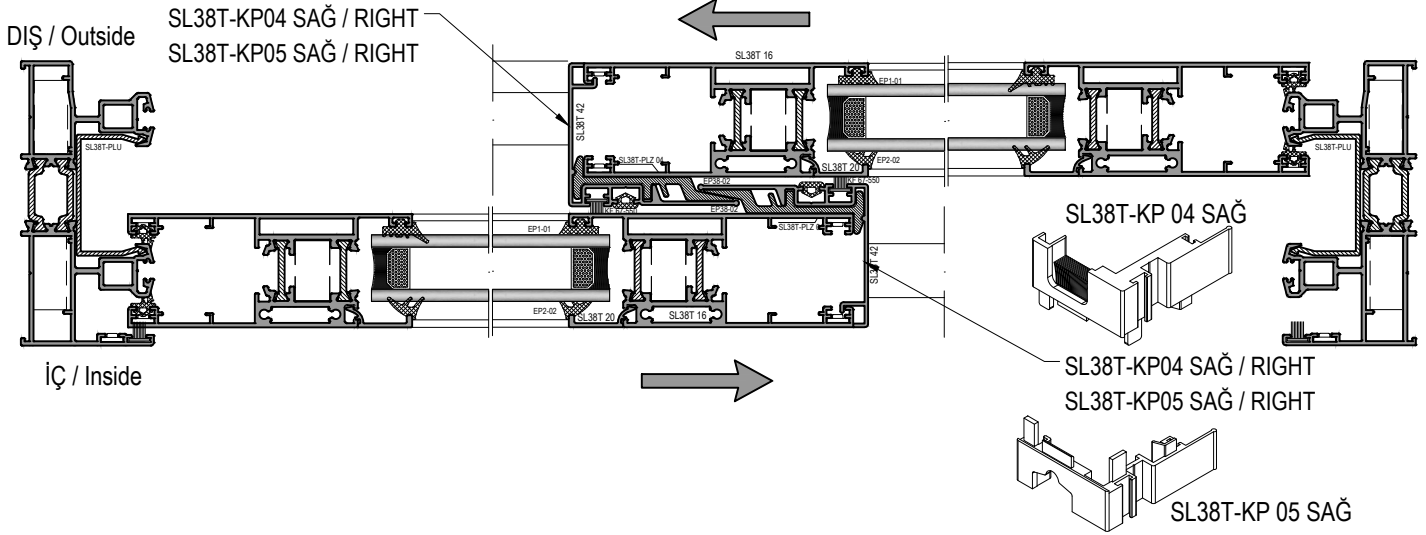

DÜZ KESİM İÇİN KENET KAPAĞI
FLAT CUTTING INTERLOCK PROFILE CAP

- KANAT AÇILIŞ YÖNÜNE GÖRE SAĞ VEYA SOL KAPAK OLARAK KULLANILACAKTIR.
COVERS WILL BE USED RIGHT OR LEFT, ACCORDING TO THE SASH SLIDING DIRECTION

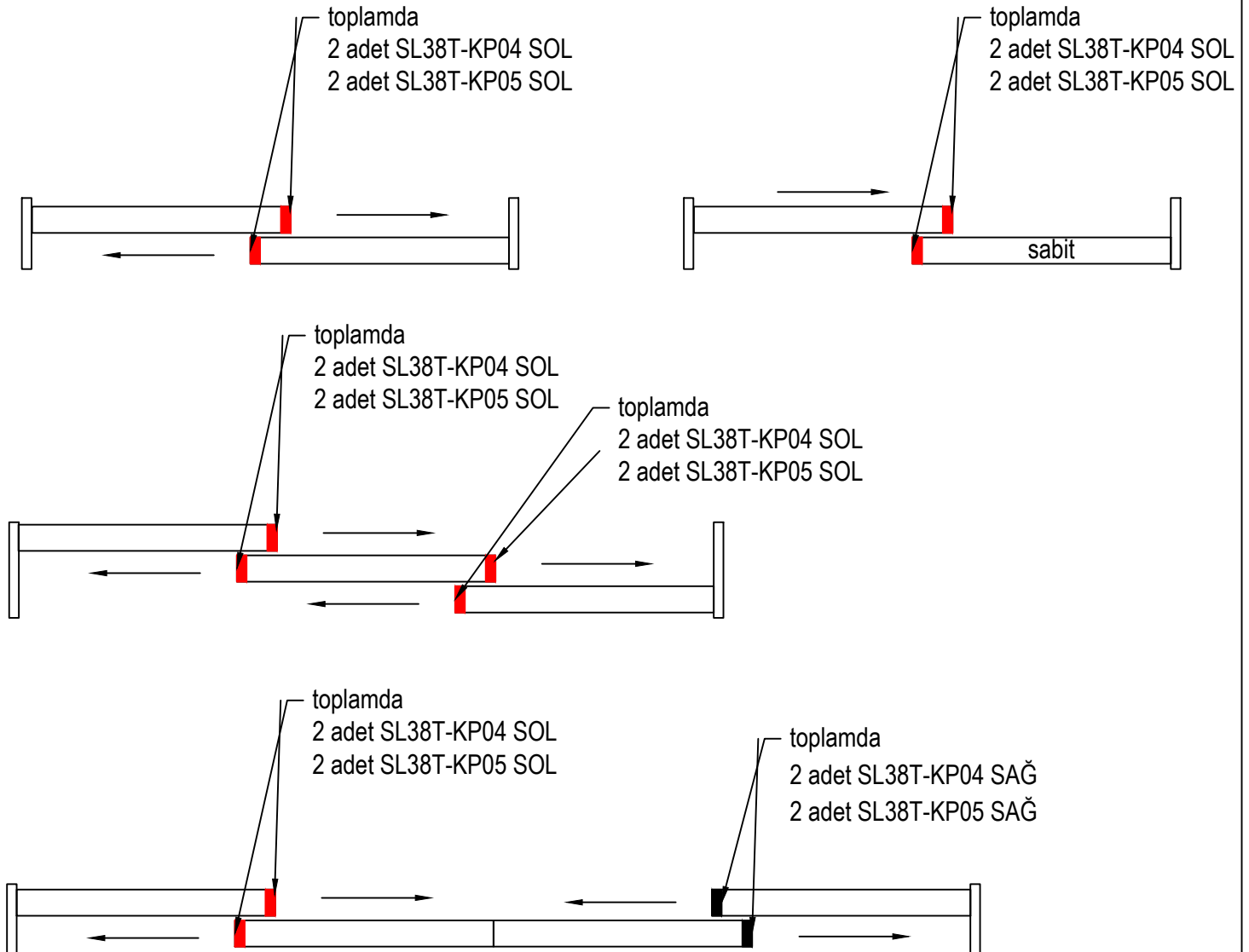
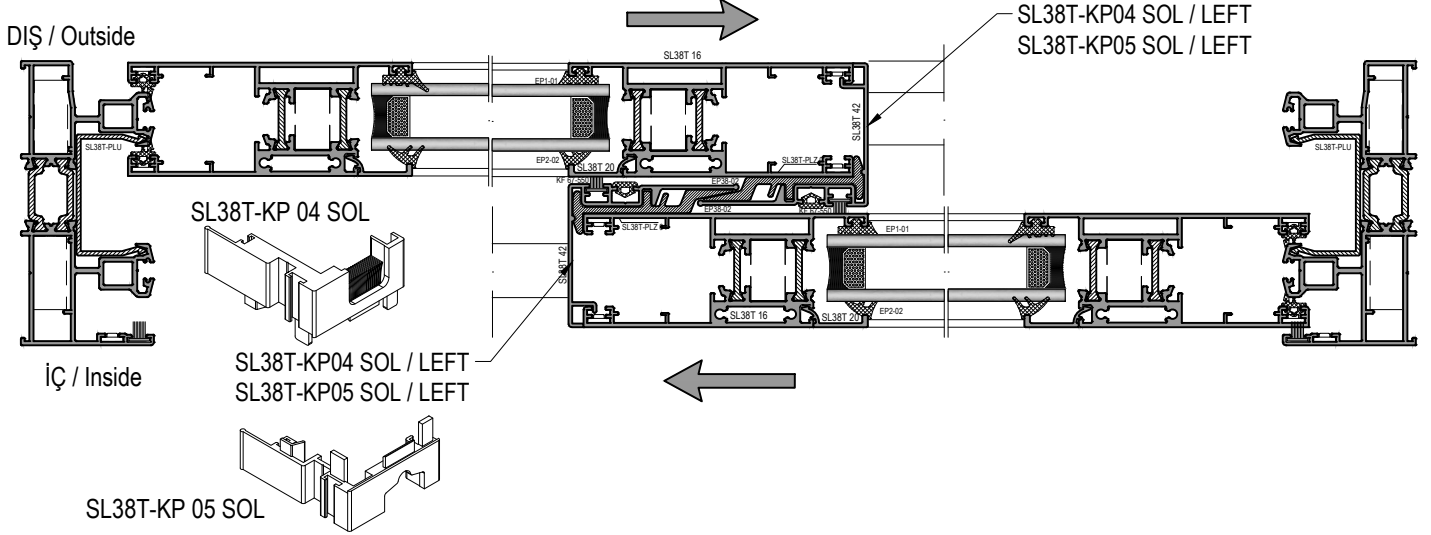

SL38T-K

YALITIMLI KALDIR-SÜR SİSTEM
THERMAL LIFT&SLIDE SYSTEM

ASISTAL

SL38T-KP 03

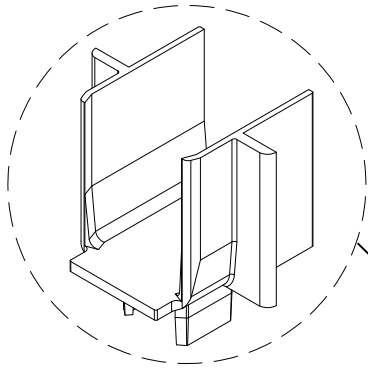

SL38T-KP 03

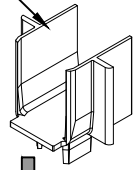

SL38T 12

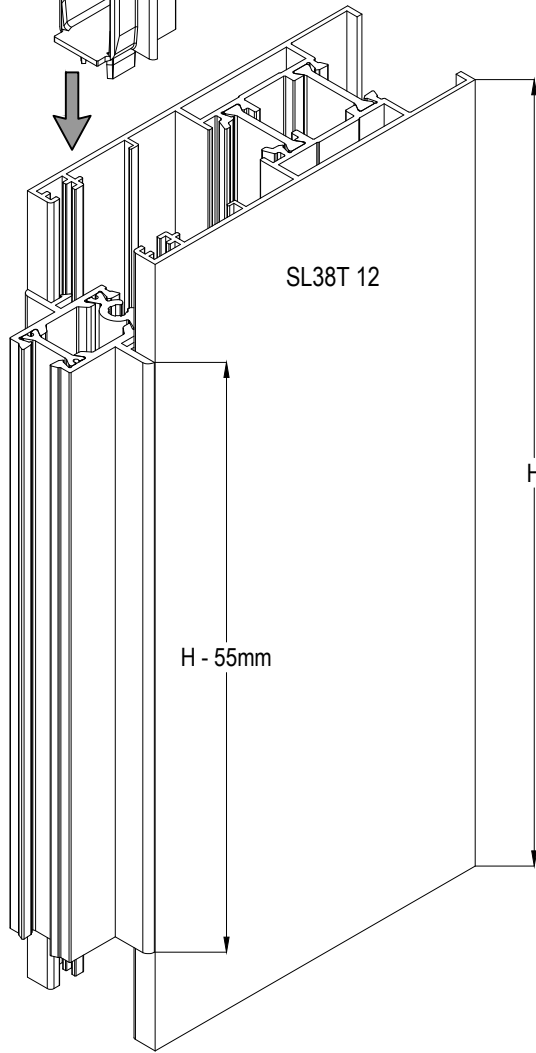

SL38T 43

SL38T-KP 03

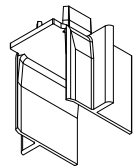

SL38T-K

YALITIMLI KALDIR-SÜR SİSTEM
THERMAL LIFT&SLIDE SYSTEM

ASISTAL

SABİTLİ KASADA ORTA KANAT SABİTLEME UYGULAMASI CENTRAL LOCKING ASSEMBLY IN FIXED FRAME PROFILE

ALT VE ÜST BİTİŞE
TOPLAM 4 ADET
ASI-PB 100 MONTAJ İÇİN
4 pieces ASI-PB 100 needed
for installation to lower and
upper finishes

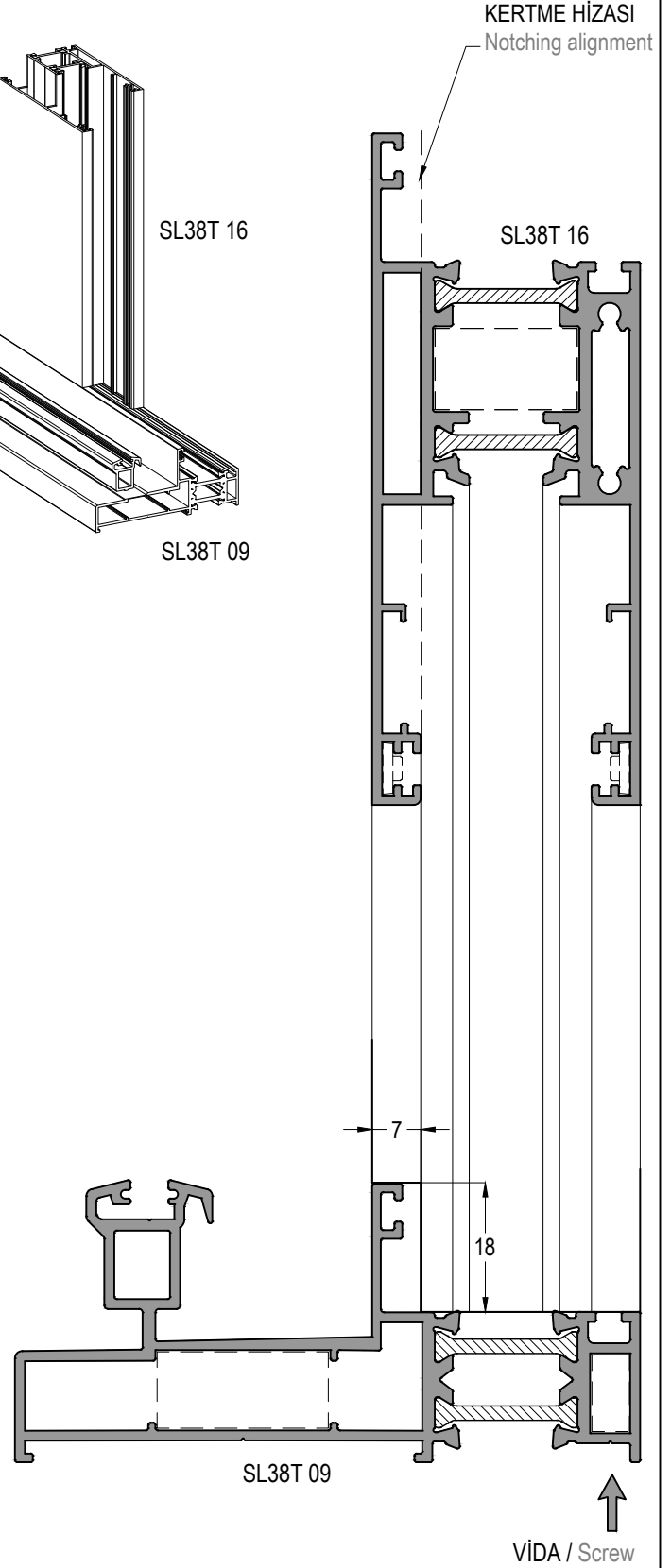
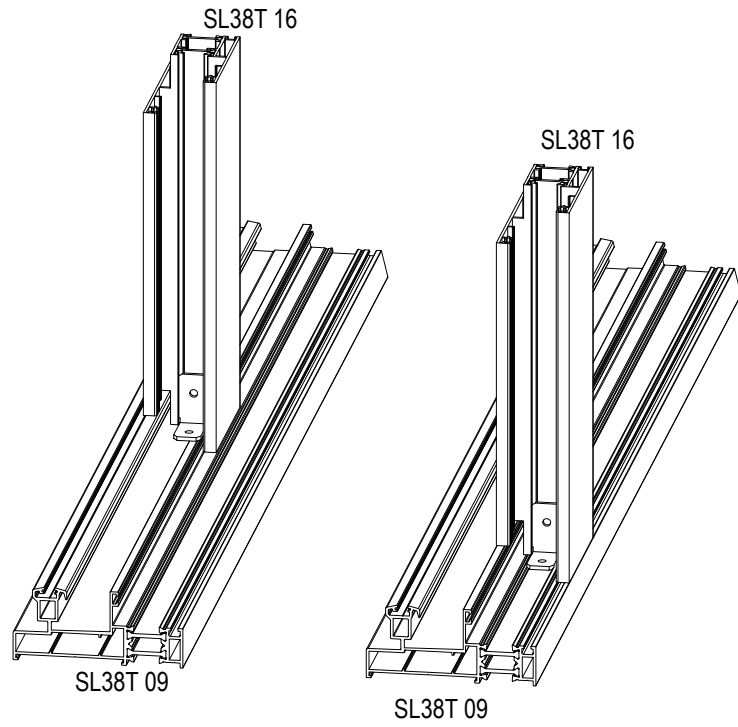
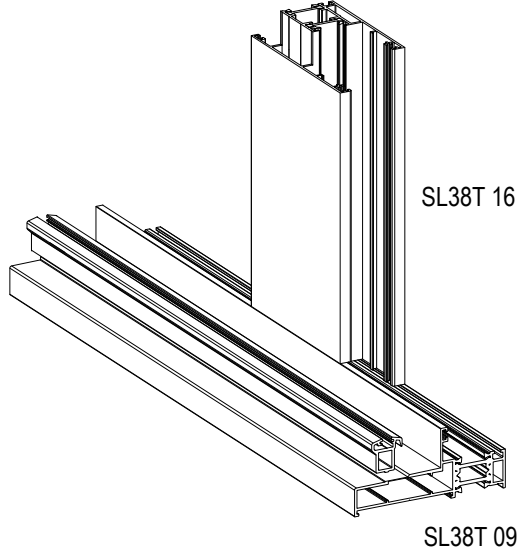
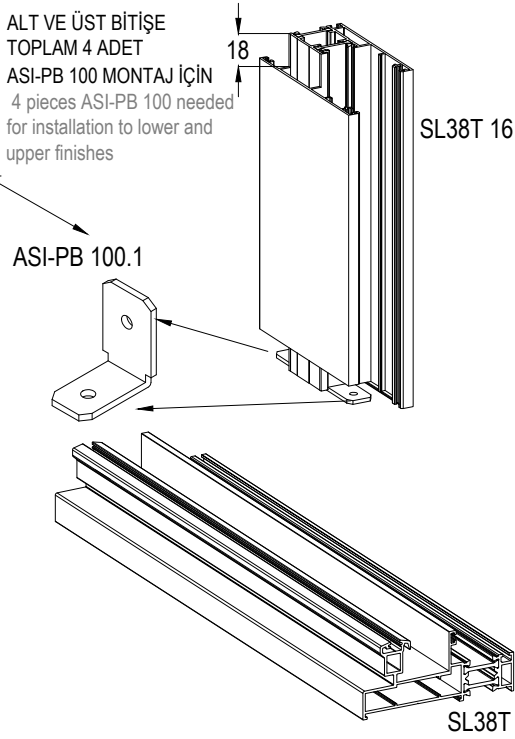

SABİTLİ KASADA TEK HAREKETLİ KANAT UYGULAMASI FIXED FRAME PROFILE ASSEMBLY WITH SINGLE SASH

SL38T 42 NOLU PROFİL
ALT VE ÜST KISIMDAN KERTİLMELİ
Must be notched from the top&bottom parts

SL38T 46 NOLU PROFİL ALT VE ÜST MONTAJDA
KASAYA GELEN KISIMDAN KERTİLMELİ
Top&Bottom sides which is colliding with the frame
shold be notched during installation

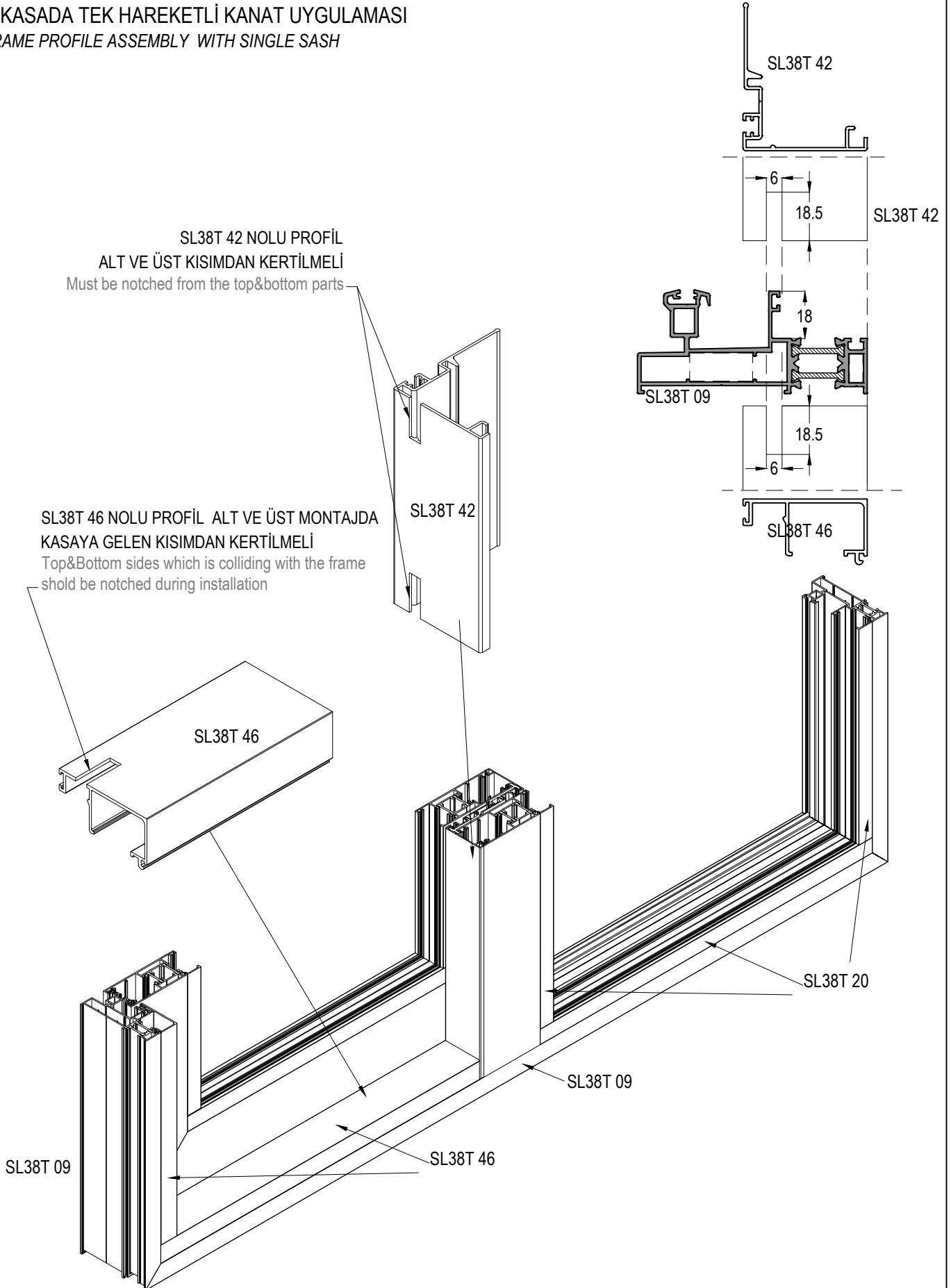

SL38T-N

YALITIMLI KALDIR-SÜR SİSTEM
THERMAL LIFT&SLIDE SYSTEM

ASISTAL

KANAT SABİTLEME SASH FIXING

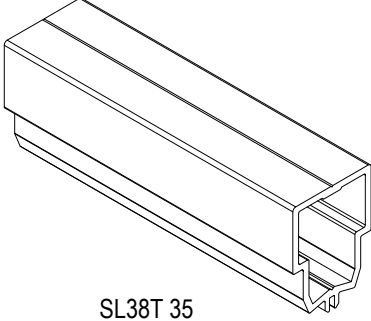

SL38T 35
(PARÇA KODU SL38T-DB100)

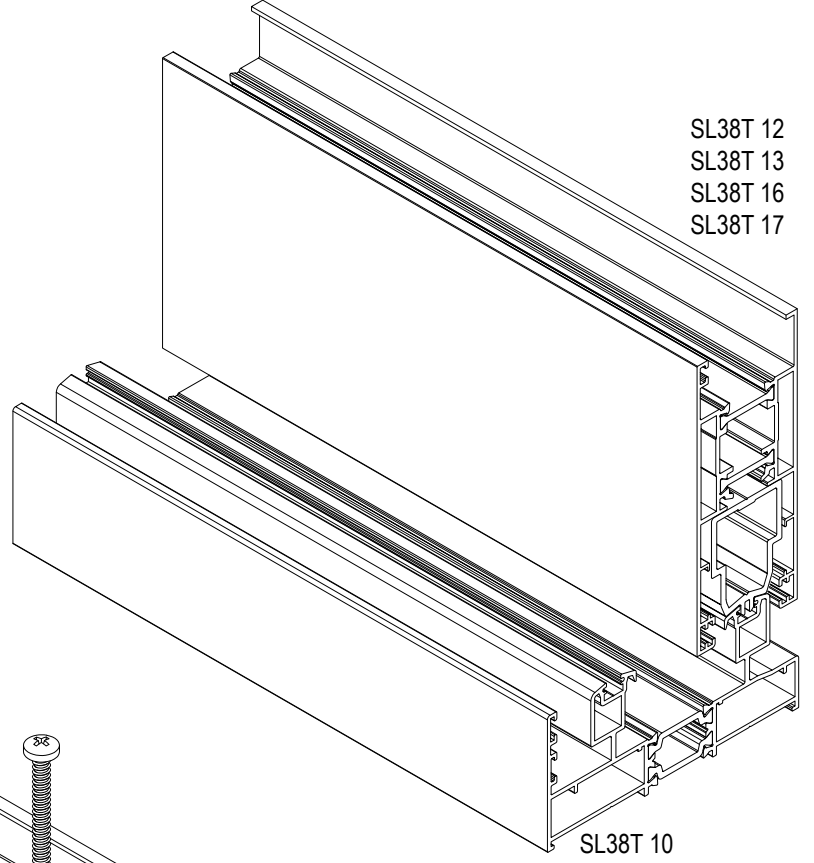

SL38T 12
SL38T 13
SL38T 16
SL38T 17

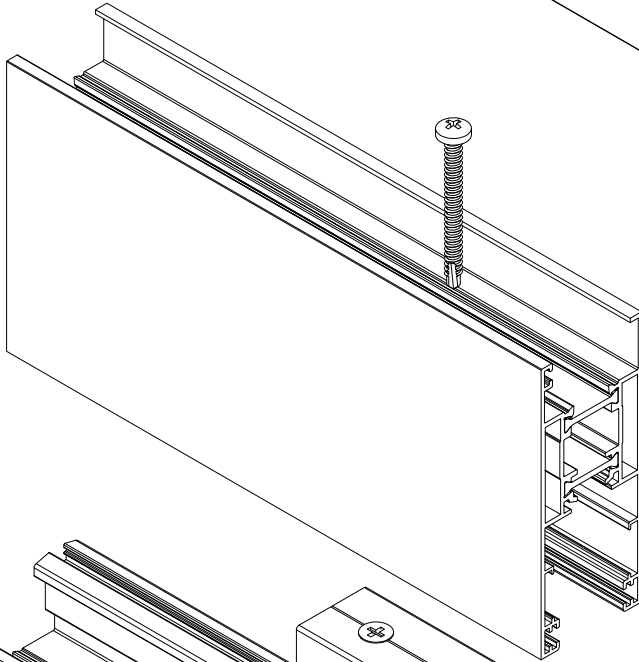

SL38T 12
SL38T 13
SL38T 16
SL38T 17

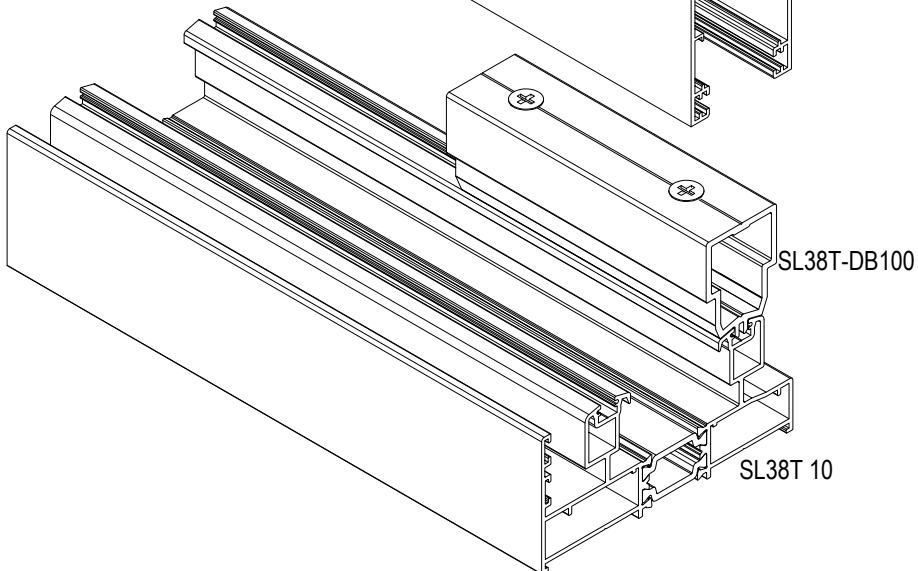

SL38T 10

SL38T SİSTEMDEN TH55 SİSTEME GEÇİŞ KASASI FRAME PROFILE BETWEEN SL38T AND TH55 SYSTEM

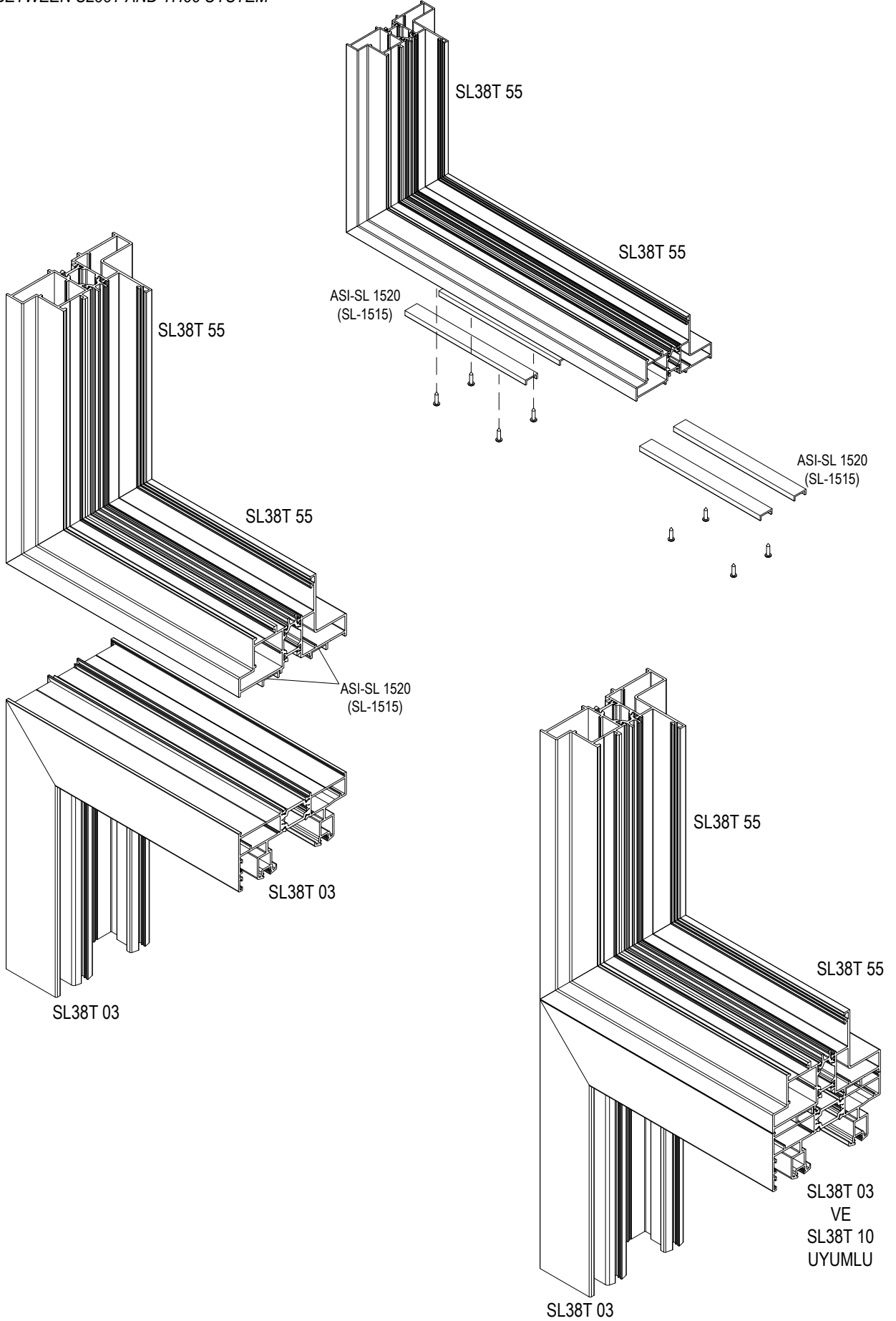

SL38T-K

YALITIMLI KALDIR-SÜR SİSTEM
THERMAL LIFT&SLIDE SYSTEM

ASISTAL

SL38T KALDIR-SÜR SİSTEMDE ALT TEKER MERKEZLEME PARÇASI MONTAJI ASSEMBLY FOR LIFT-SLIDE SYSTEM ROLLER SUPPORT ACCESSORIES.

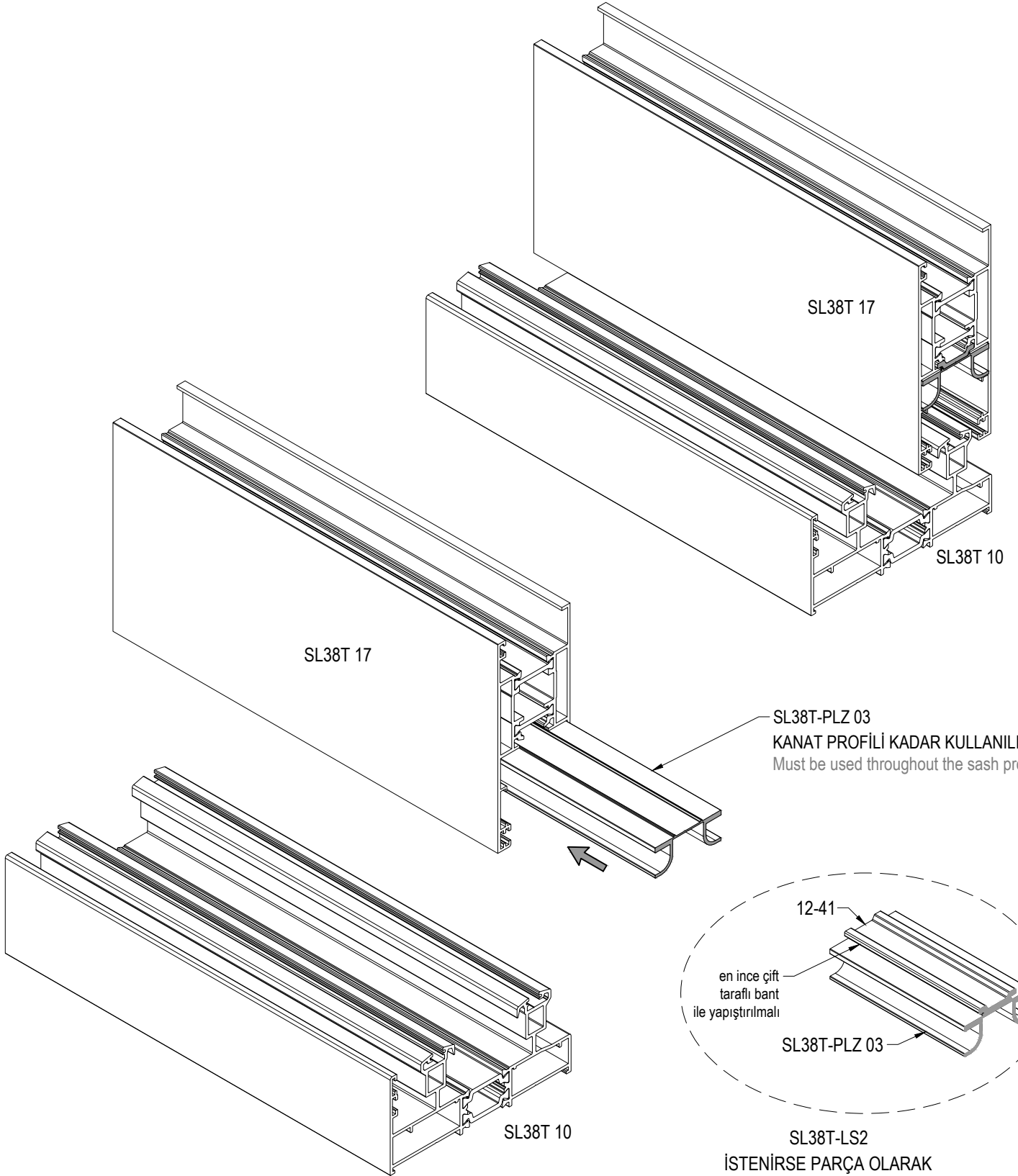

SL38T-PLZ 03
KANAT PROFİLİ KADAR KULLANILIR
Must be used throughout the sash profile

12-41
en ince çift
taraflı bant
ile yapıştırılmalı
SL38T-PLZ 03

SL38T-LS2
İSTENİRSE PARÇA OLARAK
ALÜMİNYUM TİJ PROFİLİ (12-41) EKLENEREK DE
KULLANILABİLİR

Optionally, it can be used by adding
a piece of aluminum rod profile(12-41)

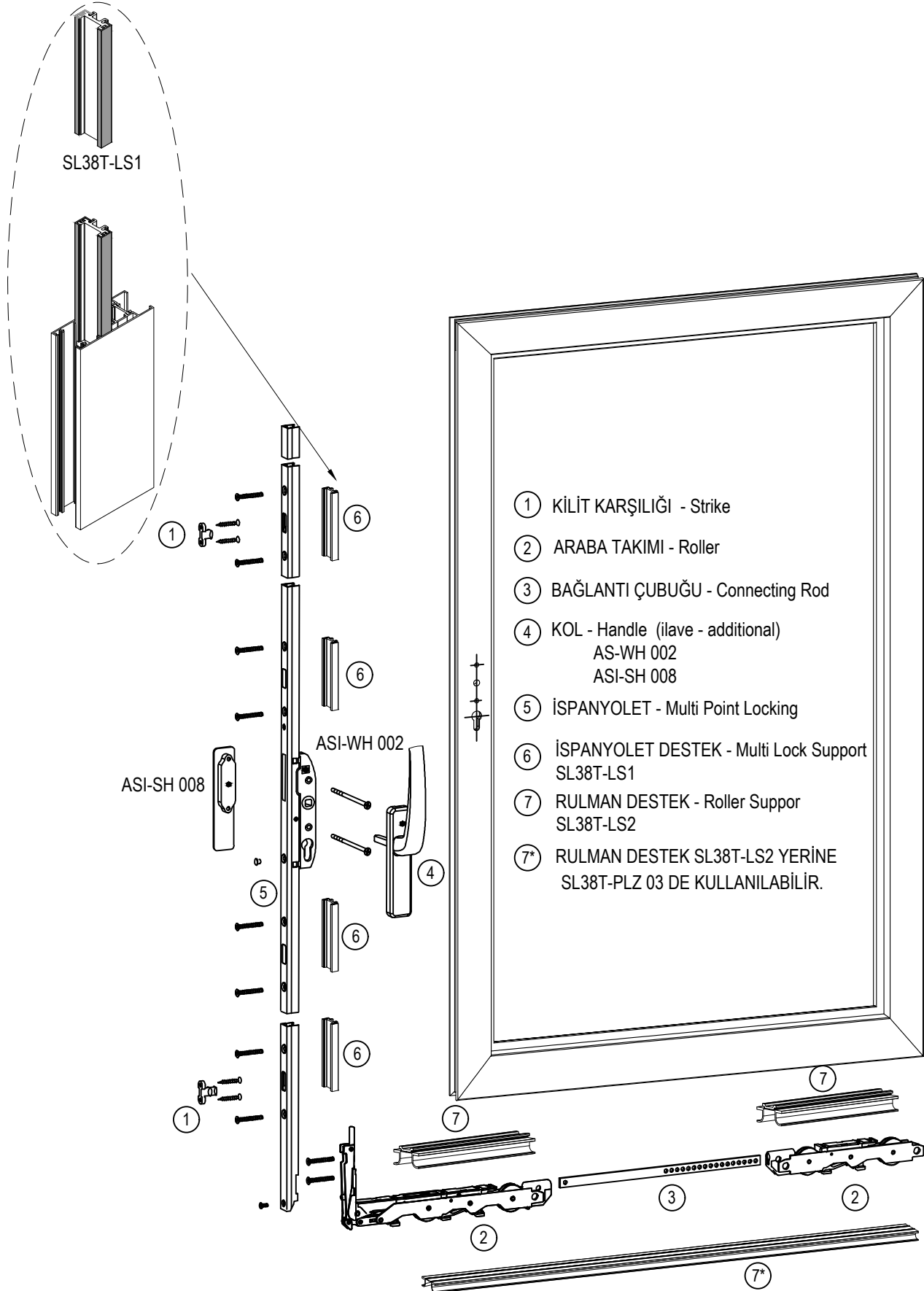
KALDIR-SÜR MEKANİZMASI MONTAJ ŞEMASI - SL38T MEK1
LIFT & SLIDING MECHANISM INSTALLATION FOR SL38T- MEK1

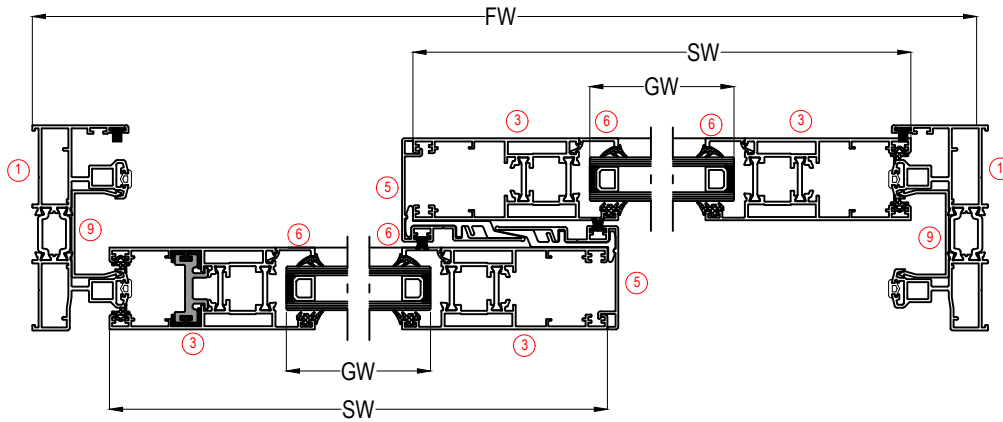
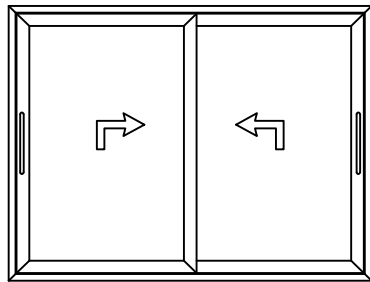
2 HAREKETLİ KANAT KESİM ÖLÇÜLERİ
2 SLIDING SASHES CUTTING SIZEKALDIR-SÜR SİSTEM
LIFT & SLIDE SYSTEM

CAM KESİM ÖLÇÜLERİ / GLASS CUTTING SIZES		
KOD / Code	TANIMI / Description	KESİM ÖLÇÜSÜ / Cutting Dimensions
GW	CAM GENİŞLİK / Sash Glass Width	GW=SW-162mm
GH	CAM YÜKSEKLİK / Sash Glass Height	GH=SH-162mm

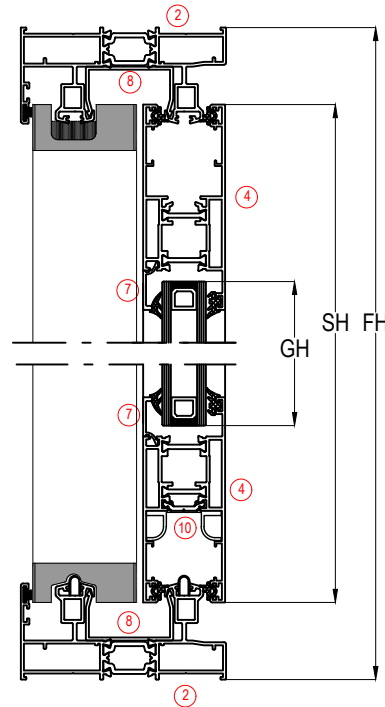

PROFİLLER / PROFILES					
NO / Number	ADET / Unit	KOD / Code	PROFİL ÇİZİMİ / Drawing	PROFİL TANIMI / Description	KESİM ÖLÇÜSÜ / Cutting Dimensions
1	2	SL38T 10		DÜŞEY KASA PROFİLİ / Vertical Frame Profile	FH
2	2	SL38T 10		YATAY KASA PROFİLİ / Horizontal Frame Profile	FW
3	4	SL38T16 SL38T17 SL38T12		DÜŞEY KANAT PROFİLİ / Vertical Sash Profile	SH=FH-71mm
4	4	SL38T16 SL38T17 SL38T12		YATAY KANAT PROFİLİ / Horizontal Frame Profile	SW=FW/2+9,2mm
5	2	SL38T42		KENET PROFİLİ / Central Locking Profile	SH - 37mm
6	4	SL38T 20		DÜŞEY CAM ÇİTASI / Vertical Glazing Bead	G1=SH-188
7	4	SL38T 20		YATAY CAM ÇİTASI / Horizontal Glazing Bead	G2=SW-152
	2	SL38T-PLZ 04		KENET PVC PROFİL / Central Locking PVC Profile	SH
8	2	SL38T-PLU		YATAY KASA KANAL PVC / Horizontal PVC Channel Profile	FW
9	2	SL38T-PLU		DÜŞEY KASA KANAL PVC / Vertical PVC Channel Profile	FH
	2	ASI-İNR 01		ÇELİK RAY PROFİLİ / Steel Rail Profile	FW-88

FİTİLLER / GASKETS				
MİKTAR / Unit	KOD / Code	PROFİL ÇİZİMİ / Drawing	PROFİL TANIMI / Description	KESİM ÖLÇÜSÜ / Cutting Dimensions
mt	EP2-02		İÇ CAM FİTİLİ / Inner Glazing Gasket	(4xG1)+(4xG2)
mt	EP38-02		KENET KANAL FİTİLİ / Screw Cover Gasket	2xSH
mt	EP1-01		DIŞ CAM FİTİLİ / Outer Glazing Gasket	(4xG1)+(4xG2)
mt	KF 67-550		FİRÇA FİTİLİ / Brush Gasket - 5,5mm	(2xFW)+(2xFH)+(2xSH)
mt	EP38-01		KANAT FİTİLİ / Sash Gasket	(4xSH)+(4xSW)
mt	EP38-05		ÜST KANAT FİTİLİ / Sash Gasket	(4xSW)
mt	EP38-02		KASA KANAL FİTİLİ / Frame Gasket	(4xFH)+(2xFW)

AKSESUARLAR / ACCESSORIES				
2 Adet / Pcs	SL38T-KP04		KENET KAPAĞI ÜST / Interlock Profile Cap Top	SAĞ veya SOL / Right or Left
2 Adet / Pcs	SL38T-KP05		KENET KAPAĞI ALT / Interlock Profile Cap Bottom	SAĞ veya SOL / Right or Left
4 Adet / Pcs	ASI-STP 06		KANAT STOPER / Sash Stopper	
1 Adet / Pcs	SL38T-SFP 01		ALT-ÜST HAVA KESİCİ EPDM / Bottom-Top Weather Protector	
1 Adet / Pcs	SL38T-SFP 02		ÜST HAVA KESİCİ EPDM / Top Weather Protector	
20 Adet / Pcs	ASI-PB 19		KÖŞE GÖNYESİ / Corner Alignment	
8 Adet / Pcs	ASI-CC 1220		ÖZEL KOŞE BAĞLANTI / Corner Joint	
8 Adet / Pcs	ASI-PB 1124 ASI-KT 1124		PİMLİ-PRESS BAĞLANTI / Corner Joint Pin	
2 Adet / Pcs	SL38T-MEK1		200 kg KAPASİTELİ KALDIR SÜR MEKANİZMA / Lift & Slide Mechanism	KOL / Handle
8 Adet / Pcs	SL38T-LS1		KALDIR-SÜR SİSTEM İSPANYOLET DESTEĞİ / Lift&Slide Locking Support	
4 Adet / Pcs	SL38T-LS2		KALDIR-SÜR SİSTEM RULMAN DESTEĞİ / Lift&Slide Roller Support	
			NOT: SL38T-LS2 YERİNE KANAT ENİ KADAR SL38T-PLZ 03 KULLANILABİLİR. 2 ADET / Pcs	

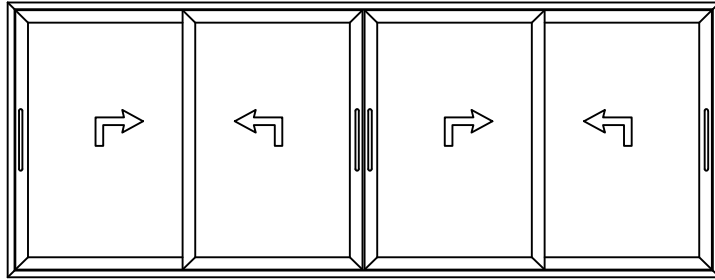
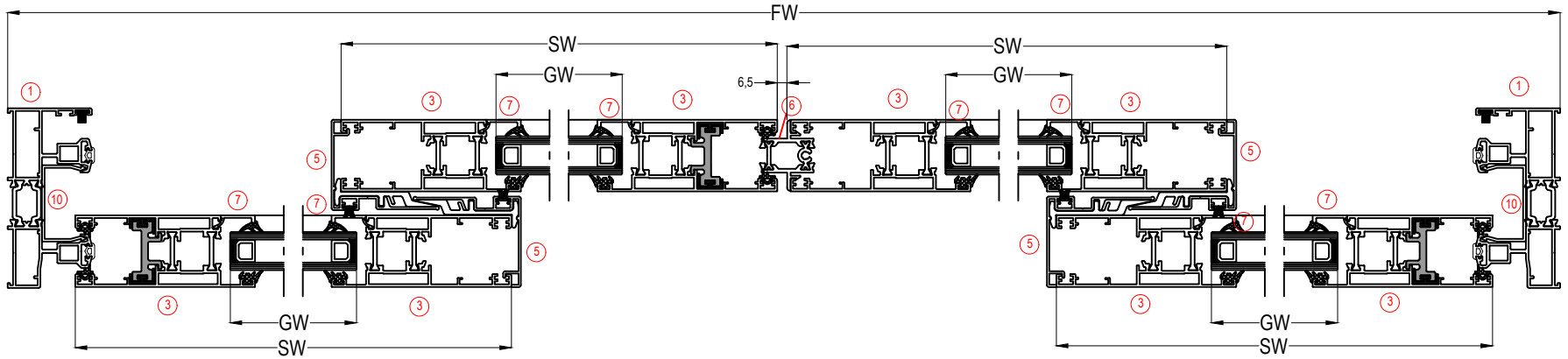
4 LÜ KANAT KESİM ÖLÇÜLERİ
4 SLIDING SASH CUTTING SIZESKALDIR-SÜR SİSTEM
LIFT & SLIDE SYSTEM

FİTİLLER / GASKETS

MİKTAR / Unit	KOD / Code	PROFİL ÇİZİMİ / Drawing	PROFİL TANIMI / Description	KESİM ÖLÇÜSÜ / Cutting Dimensions
mt	EP2-02		İÇ CAM FİTİLİ / Inner Glazing Gasket	(8xG1)+(8xG2)
mt	EP38-02		KENET KANAL FİTİLİ / Screw Cover Gasket	4xSH
mt	EP1-01		DIŞ CAM FİTİLİ / Outer Glazing Gasket	(8xG1)+(8xG2)
mt	KF 67-550		FİRÇA FİTİLİ / Brush Gasket - 5,5mm	(2xFW)+(2xFH)+(4xSH)
mt	EP38-01		KANAT FİTİLİ / Sash Gasket	(6xSH)+(8xSW)
mt	EP38-05		ÜST KANAT FİTİLİ / Sash Gasket	(8xSW)
mt	EP38-02		KASA KANAL FİTİLİ / Frame Gasket	(4xFH)+(2xFW)

AKSESUARLAR / ACCESSORIES

2 Adet / Pcs	SL38T-KP04 SAG		KENET KAPAĞI ÜST / Interlock Profile Cap Top	
2 Adet / Pcs	SL38T-KP05 SAG		KENET KAPAĞI ALT / Interlock Profile Cap Bottom	
2 Adet / Pcs	SL38T-KP04 SOL		KENET KAPAĞI ÜST / Interlock Profile Cap Top	
2 Adet / Pcs	SL38T-KP05 SOL		KENET KAPAĞI ALT / Interlock Profile Cap Bottom	
8 Adet / Pcs	ASI-STP 06		KANAT STOPER / Sash Stopper	
2 Adet / Pcs	SL38T-SFP 01		ALT-ÜST HAVA KESİCİ EPDM / Bottom-Top Weather Protector	
2 Adet / Pcs	SL38T-SFP 02		ÜST HAVA KESİCİ EPDM / Top Weather Protector	
2 Adet / Pcs	SL38T-KP 03		4'LÜ KANAT ADAPTÖR KAPAĞI / Adapter Cover	
36 Adet / Pcs	ASI-PB 19		KÖŞE GÖNYESİ / Corner Alignment	
16 Adet / Pcs	ASI-CC 1220		OZEL KOŞE BAĞLANTI / Corner Joint	
8 Adet / Pcs	ASI-PB 1124 ASI-KT 1124		PİMLİ-PRESS BAĞLANTI / Corner Joint Pin	
2 Adet / Pcs	SL38T-MEK1		KALDIR SÜR MEKANİZMA / Lift & Slide Mechanism	KOL / Handle
1 Takım / Set	SL38T-MEK1D		4'LÜ KANAT ORTA KİLİTLEME KALDIR SÜR MEKANİZMA / Lift & Slide Mechanism For Central Locking	KOL / Handle
16 Adet / Pcs	SL38T-LS1		KALDIR-SÜR SİSTEM İSPANYOLET DESTEĞİ / Lift&Slide Locking Support	
8 Adet / Pcs	SL38T-LS2		KALDIR-SÜR SİSTEM RULMAN DESTEĞİ / Lift&Slide Roller Support	
			NOT: SL38T-LS2 YERİNE KANAT ENİ KADAR SL38T-PLZ 03 KULLANILABİLİR. 4 ADET / Pcs	

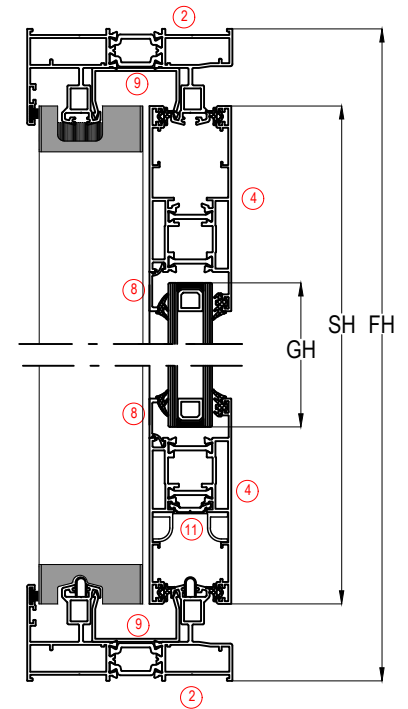

CAM KESİM ÖLÇÜLERİ / GLASS CUTTING SIZES

KOD / Code	TANIMI / Description	KESİM ÖLÇÜSÜ / Cutting Dimensions
GW	HAREKETLİ KANAT CAM GENİŞLİK / Sash Glass Width	GW=SW-162mm
GH	HAREKETLİ KANAT CAM YÜKSEKLİK / Sash Glass Height	GH=SH-162mm

PROFİLLER / PROFILES					
NO / Number	ADET / Unit	KOD / Code	PROFİL ÇİZİMİ / Drawing	PROFİL TANIMI / Description	KESİM ÖLÇÜSÜ / Cutting Dimensions
1	2	SL38T 10		DÜŞEY KASA PROFİLİ / Vertical Frame Profile	FH
2	2	SL38T 10		YATAY KASA PROFİLİ / Horizontal Frame Profile	FW
3	8	SL38T16 SL38T17 SL38T12		DÜŞEY KANAT PROFİLİ / Vertical Sash Profile	SH=FH-71mm
4	8	SL38T16 SL38T17 SL38T12		YATAY KANAT PROFİLİ / Horizontal Frame Profile	SW=FW/4+25mm
5	4	SL38T42		KENET PROFİLİ / Central Locking Profile	SH - 37mm
6	1	SL38T43		ADAPTÖR PROFİLİ / Adapter Profile	SL38T 43= SH-55mm
7	8	SL38T 20		DÜŞEY CAM ÇİTASI / Vertical Glazing Bead	G1=SH-188
8	8	SL38T 20		YATAY CAM ÇİTASI / Horizontal Glazing Bead	G2=SW-152
	4	SL38T-PLZ 04		KENET PVC PROFİL / Central Locking PVC Profile	SH
9	2	SL38T-PLU		YATAY KASA KANAL PVC / Horizontal PVC Channel Profile	FW
10	2	SL38T-PLU		DÜŞEY KASA KANAL PVC / Vertical PVC Channel Profile	FH
	2	ASI-INR 01		ÇELİK RAY PROFİLİ / Steel Rail Profile	FW-88

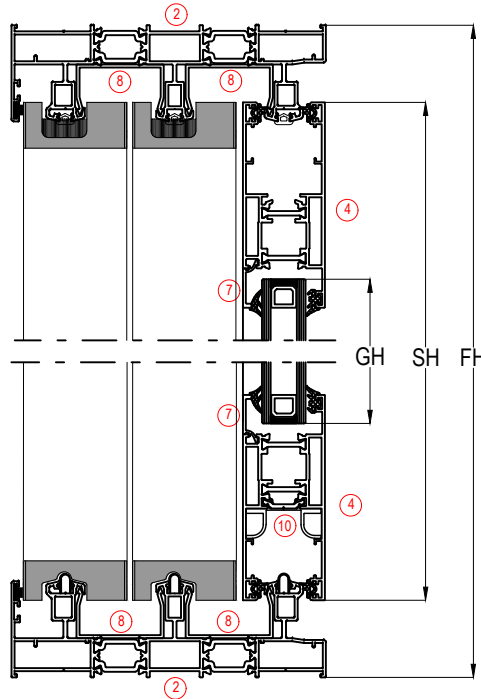
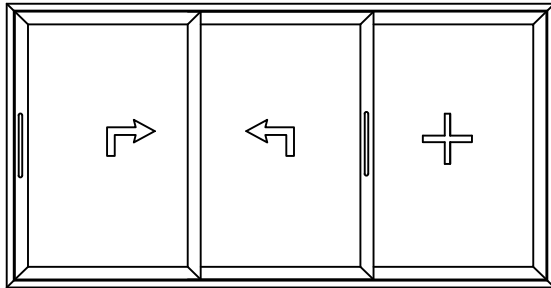
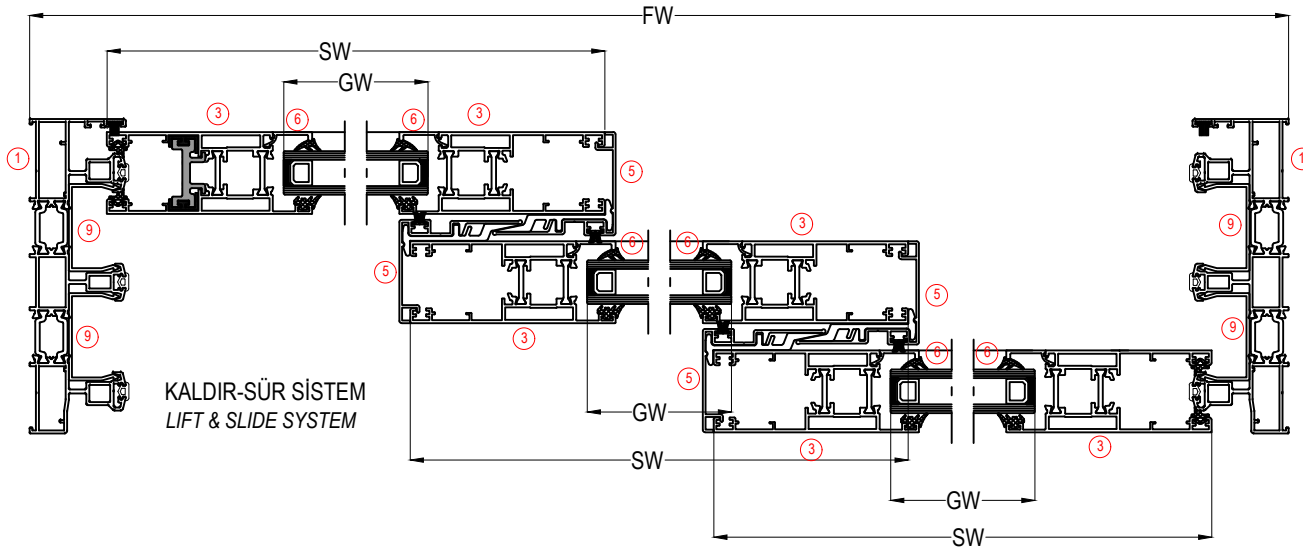
3 LÜ KANAT KESİM ÖLÇÜLERİ
3 SLIDING SASH CUTTING SIZES

CAM KESİM ÖLÇÜLERİ / GLASS CUTTING SIZES

KOD / Code	TANIMI / Description	KESİM ÖLÇÜSÜ / Cutting Dimensions
GW	CAM GENİŞLİK / Sash Glass Width	GW=SW-162mm
GH	CAM YÜKSEKLİK / Sash Glass Height	GH=SH-162mm

PROFİLLER / PROFILES

NO / Number	ADET / Unit	KOD / Code	PROFİL ÇİZİMİ / Drawing	PROFİL TANIMI / Description	KESİM ÖLÇÜSÜ / Cutting Dimensions
1	2	SL38T 101		DÜŞEY KASA PROFİLİ / Vertical Frame Profile	FH
2	2	SL38T 101		YATAY KASA PROFİLİ / Horizontal Frame Profile	FW
3	6	SL38T16 SL38T17 SL38T12		DÜŞEY KANAT PROFİLİ / Vertical Sash Profile	SH=FW-71mm
4	6	SL38T16 SL38T17 SL38T12		YATAY KANAT PROFİLİ / Horizontal Frame Profile	SW=FW/3+35,8mm
5	4	SL38T42		KENET PROFİLİ / Central Locking Profile	SH - 37mm
6	6	SL38T 20		DÜŞEY CAM ÇITASI / Vertical Glazing Bead	G1=SH-188
7	6	SL38T 20		YATAY CAM ÇITASI / Horizontal Glazing Bead	G2=SW-152
	4	SL38T-PLZ 04		KENET PVC PROFİL / Central Locking PVC Profile	SH
8	4	SL38T-PLU		YATAY KASA KANAL PVC / Horizontal PVC Channel Profile	FW
9	4	SL38T-PLU		DÜŞEY KASA KANAL PVC / Vertical PVC Channel Profile	FH
	3	ASI-INR 01		ÇELİK RAY PROFİLİ / Steel Rail Profile	FW-88

FİTİLLER / GASKETS

MIKTAR / Unit	KOD / Code	PROFİL ÇİZİMİ / Drawing	PROFİL TANIMI / Description	KESİM ÖLÇÜSÜ / Cutting Dimensions
mt	EP2-02		İÇ CAM FİTİLİ / Inner Glazing Gasket	(6xG1)+(6xG2)
mt	EP38-02		KENET KANAL FİTİLİ / Screw Cover Gasket	4xSH
mt	EP1-01		DIŞ CAM FİTİLİ / Outer Glazing Gasket	(6xG1)+(6xG2)
mt	KF 67-550		FİRÇA FİTİLİ / Brush Gasket - 5,5mm	(2xFW)+(2xFH)+(4xSH)
mt	EP38-01		KANAT FİTİLİ / Sash Gasket	(4xSH)+(6xSW)
mt	EP38-05		ÜST KANAT FİTİLİ / Sash Gasket	(6xSW)
mt	EP38-02		KASA KANAL FİTİLİ / Frame Gasket	(6xFH)+(3xFW)

AKSESUARLAR / ACCESSORIES

4 Adet / Pcs	SL38T-KP04		KENET KAPAĞI ÜST / Interlock Profile Cap Top	SAĞ veya SOL/ Right or Left
4 Adet / Pcs	SL38T-KP05		KENET KAPAĞI ALT / Interlock Profile Cap Bottom	SAĞ veya SOL/ Right or Left
6 Adet / Pcs	ASI-STP 06		KANAT STOPER / Sash Stopper	
2 Adet / Pcs	SL38T-SFP 01		ALT-ÜST HAVA KESİCİ EPDM / Bottom-Top Weather Protector	
2 Adet / Pcs	SL38T-SFP 02		ÜST HAVA KESİCİ EPDM / Top Weather Protector	
28 Adet / Pcs	ASI-PB 19		KÖŞE GÖNYESİ / Corner Alignment	
12 Adet / Pcs	ASI-CC 1220		OZEL KOSE BAĞLANTI / Corner Joint	
8 Adet / Pcs	ASI-PB 1124 ASI-KT 1124		PİMLİ-PRESS BAĞLANTI / Corner Joint Pin	
2 Adet / Pcs	SL38T-MEK1		200 kg KAPASİTELİ KALDIR SÜR MEKANİZMA / Lift & Slide Mechanism	KOL / Handle
8 Adet / Pcs	SL38T-LS1		KALDIR-SÜR SİSTEM İSPANYOLET DESTEĞİ / Lift&Slide Locking Support	
6 Adet / Pcs	SL38T-LS2		KALDIR-SÜR SİSTEM RULMAN DESTEĞİ / Lift&Slide Roller Support	
			NOT: SL38T-LS2 YERİNE KANAT ENİ KADAR SL38T-PLZ 03 KULLANILABİLİR - 3 ADET/Pcs	

ASİSTAL

SABİTLİ KASADA 1 HAREKETLİ KANAT KESİM ÖLÇÜLERİ

1 SLIDING SASH IN FIXED FRAME CUTTING SIZE

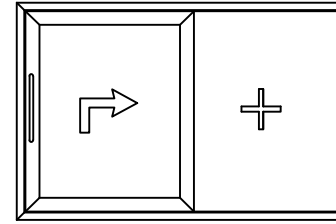
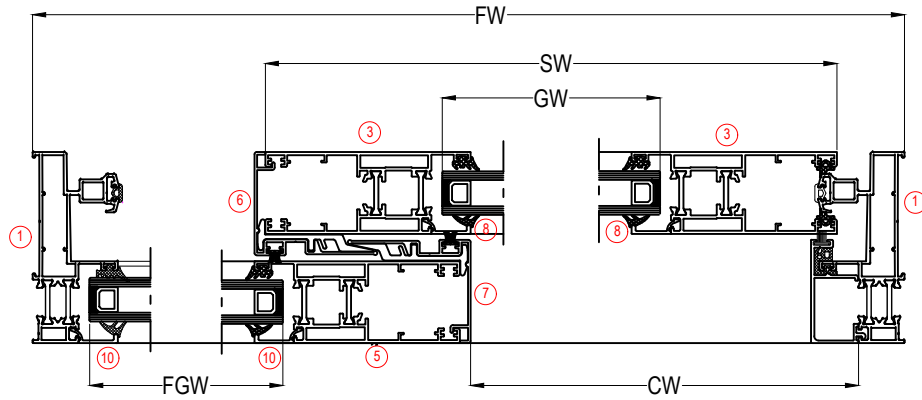

CAM KESİM ÖLÇÜLERİ / GLASS CUTTING SIZES

KOD / Code	TANIMI / Description	KESİM ÖLÇÜSÜ / Cutting Dimensions
GW	HAREKETLİ KANAT CAM GENİŞLİK / Sash Glass Width	GW=SW - 162mm
GH	HAREKETLİ KANAT CAM YÜKSEKLİK / Sash Glass Height	GH=SH - 162mm
FGW	SABİT KISIM CAM GENİŞLİK / Fixed Glass Width	FGW=FW/2 - 106mm
FGH	SABİT KISIM CAM YÜKSEKLİK / Fixed Glass Height	FGH=FH - 52mm

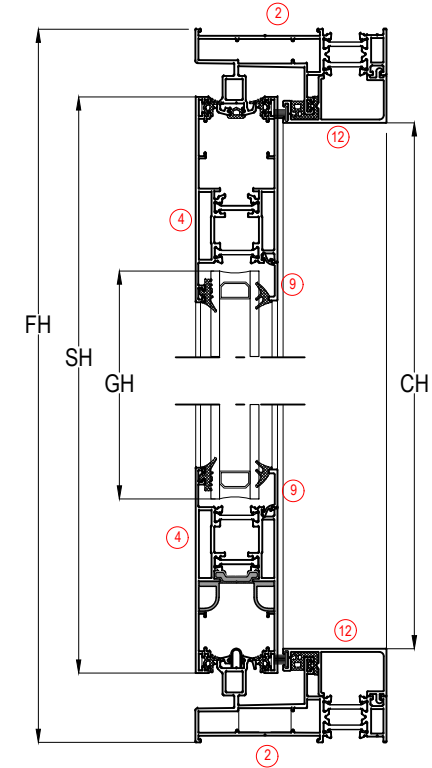

PROFİLLER / PROFILES					
NO / Number	ADET / Unit	KOD / Code	PROFİL ÇİZİMİ / Drawing	PROFİL TANIMI / Description	KESİM ÖLÇÜSÜ / Cutting Dimensions
1	2	SL38T 09		DÜŞEY KASA PROFİLİ / Vertical Frame Profile	FH
2	2	SL38T 09		YATAY KASA PROFİLİ / Horizontal Frame Profile	FW
3	2	SL38T16 SL38T17 SL38T12		DÜŞEY KANAT PROFİLİ / Vertical Sash Profile	SH=FH-62,5mm
4	2	SL38T16 SL38T17 SL38T12		YATAY KANAT PROFİLİ / Horizontal Frame Profile	SW=FW/2+56mm
5	1	SL38T 16		ORTA KAYIT KANAT PROFİLİ	FH - 42mm
6	1	SL38T42		KENET PROFİLİ / Central Locking Profile	SH - 37mm
7	1	SL38T 42		ORTA KAYIT KENET PROFİLİ / Transom Cover	FH - 42mm
8	2	SL38T 20		KANAT DÜŞEY CAM ÇİTASI / Sash Vertical Glazing Bead	G1=SH-188
9	2	SL38T 20		KANAT YATAY CAM ÇİTASI / Sash Horizontal Glazing Bead	G2=SW-152
10	2	SL38T 20		SABİT DÜŞEY CAM ÇİTASI / Fixed Vertical Glazing Bead	G4=FH - 78mm
11	2	SL38T 20		SABİT YATAY CAM ÇİTASI / Fixed Horizontal Glazing Bead	G3=FW/2-96mm
12	2	SL38T 46		SABİT KASA ALT-ÜST KAPAK PROFİLİ / Top-Bottom Cover Profile	CW=FW/2 - 27mm
13	1	SL38T 46		SABİT KASA DÜŞEY KAPAK PROFİLİ / Vertical Cover Profile	CH=FH - 86mm
	2	SL38T-PLZ 04		KENET PVC PROFİL / Central Locking PVC Profile	SH-37mm
	1	ASI-INR 01		ÇELİK RAY PROFİLİ / Steel Rail Profile	FW-70

FİTİLLER / GASKETS

MİKTAR / Unit	KOD / Code	PROFİL ÇİZİMİ / Drawing	PROFİL TANIMI / Description	KESİM ÖLÇÜSÜ / Cutting Dimensions
mt	EP2-02		İÇ CAM FİTİLİ / Inner Glazing Gasket	2 x (G1+G2+G3+G4)
mt	EP38-02		KENET KANAL FİTİLİ / Screw Cover Gasket	2 x SH
mt	EP1-01		DIŞ CAM FİTİLİ / Outer Glazing Gasket	2 x (G1+G2+G3+G4)
mt	KF 67-550		FİRÇA FİTİL / Brush Gasket - 5,5mm	(2xSH) + CH + (2xCW)
mt	EP38-01		KANAT FİTİLİ / Sash Gasket	(2xSH) + (2xSW)
mt	EP38-05		ÜST KANAT FİTİLİ / Sash Gasket	(2xSW)
mt	EP38-02		KASA KANAL FİTİLİ / Frame Gasket	(2xFH) + FW
mt	EP38-03		SABİT ÇİTA FİTİLİ / Fixed Frame Gasket	2xCW+CH

AKSESUARLAR / ACCESSORIES

1 Adet / Pcs	SL38T-KP 04		KENET KAPAĞI ÜST / Interlock Profile Cap Top	SAG veya SOLU / Right or Left
1 Adet / Pcs	SL38T-KP 05		KENET KAPAĞI ALT / Interlock Profile Cap Bottom	SAG veya SOLU / Right or Left
2 Adet / Pcs	ASI-STP 06		KANAT STOPER / Sash Stopper	
1 Adet / Pcs	SL38T-SFP 04		ALT HAVA KESİCİ EPDM / Bottom Top Weather Protector	
1 Adet / Pcs	SL38T-SFP 03		ÜST HAVA KESİCİ EPDM / Top Weather Protector	
8 Adet / Pcs	ASI-PB 19		KÖŞE GÖNYESİ / Corner Alignment	
4 Adet / Pcs	ASI-CC 1220		OZEL KOŞE BAĞLANTI / Corner Joint	
4 Adet / Pcs	ASI-PB 1124 ASI-KT 1124		PİMLİ-PRESS BAĞLANTI / Corner Joint Pin	
4 Adet / Pcs	ASI-KT 1105		KÖŞE TAKOZU / Corner Joint	
1 Adet / Pcs	SL38T-MEK1		200 kg KAPASİTELİ KALDIR SÜR MEKANİZMA / Lift & Slide Mechanism	KOL / Handle
4 Adet / Pcs	SL38T-LS1		KALDIR-SÜR SİSTEM İSPANYOLET DESTEĞİ / Lift&Slide Locking Support	
2 Adet / Pcs	SL38T-LS2		KALDIR-SÜR SİSTEM RULMAN DESTEĞİ / Lift&Slide Roller Support	
4 Adet / Pcs	ASI-P 100.1		ORTA KAYIT DİK BAĞLANTI / T Joint	

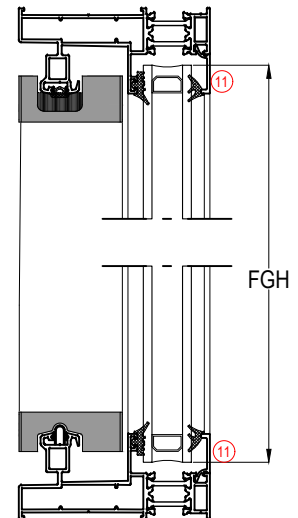

SL38T-K

YALITIMLI KALDIR-SÜR SİSTEM
THERMAL LIFT&SLIDE SYSTEM

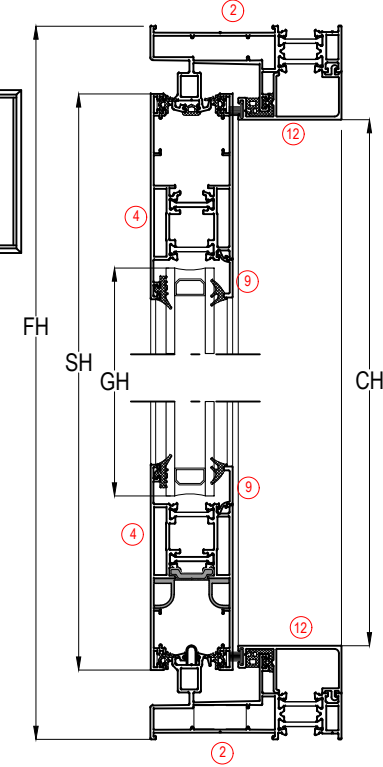
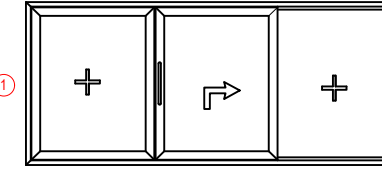
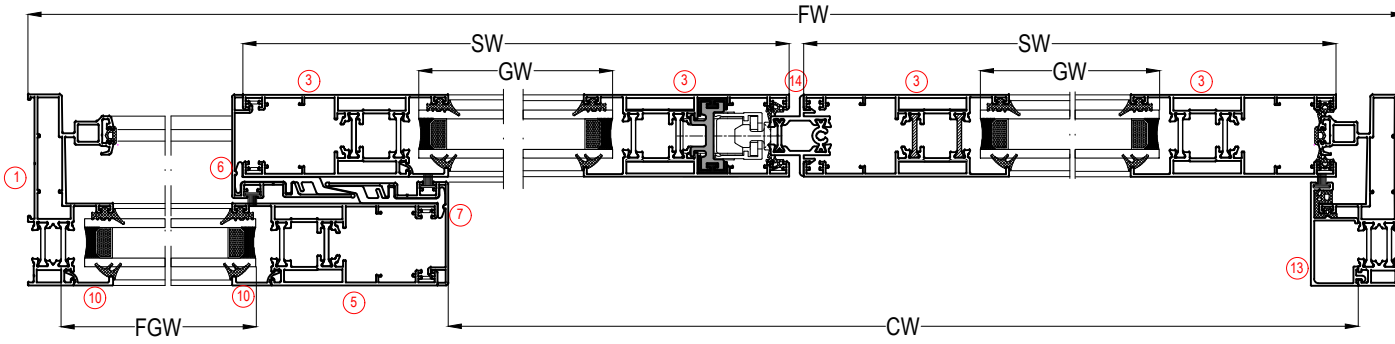

CAM KESİM ÖLÇÜLERİ / GLASS CUTTING SIZES		
KOD / Code	TANIMI / Description	KESİM ÖLÇÜSÜ / Cutting Dimensions
GW	HAREKETLİ KANAT CAM GENİŞLİK / Sash Glass Width	GW=SW - 162mm
GH	HAREKETLİ KANAT CAM YÜKSEKLİK / Sash Glass Height	GH=SH - 162mm
FGW	SABİT KISIM CAM GENİŞLİK / Fixed Glass Width	FGW=FW/3 - 127mm
FGH	SABİT KISIM CAM YÜKSEKLİK / Fixed Glass Height	FGH=FH - 52mm

PROFİLLER / PROFILES					
NO / Number	ADET / Unit	KOD / Code	PROFİL ÇİZİMİ / Drawing	PROFİL TANIMI / Description	KESİM ÖLÇÜSÜ / Cutting Dimensions
1	2	SL38T 09		DÜŞEY KASA PROFİLİ / Vertical Frame Profile	FH
2	2	SL38T 09		YATAY KASA PROFİLİ / Horizontal Frame Profile	FW
3	4	SL38T16 SL38T17 SL38T12		DÜŞEY KANAT PROFİLİ / Vertical Sash Profile	SH=FH-62,5mm
4	4	SL38T16 SL38T17 SL38T12		YATAY KANAT PROFİLİ / Horizontal Frame Profile	SW=FW/3+35mm
5	1	SL38T 16		ORTA KAYIT KANAT PROFİLİ	FH - 42mm
6	1	SL38T42		KENET PROFİLİ / Central Locking Profile	SH - 37mm
7	1	SL38T 42		ORTA KAYIT KENET PROFİLİ / Transom Cover	FH - 42mm
8	4	SL38T 20		KANAT DÜŞEY CAM ÇİTASI (SL38T 16 KANAT İÇİN) / Sash Vertical Glazing Bead	G1=SH-188
9	4	SL38T 20		KANAT YATAY CAM ÇİTASI (SL38T 16 KANAT İÇİN) / Sash Horizontal Glazing Bead	G2=SW-152
10	2	SL38T 20		SABİT DÜŞEY CAM ÇİTASI / Fixed Vertical Glazing Bead	G4=FH - 78mm
11	2	SL38T 20		SABİT YATAY CAM ÇİTASI / Fixed Horizontal Glazing Bead	G3=FW/3-117mm
12	2	SL38T 46		SABİT KASA ALT-ÜST KAPAK PROFİLİ / Top-Bottom Cover Profile	CW=(FW/3)x2 - 6,5mm
13	1	SL38T 46		SABİT KASA DÜŞEY KAPAK PROFİLİ / Vertical Cover Profile	CH=FH - 86mm
14	1	SL38T43		ADAPTÖR PROFİLİ / Adapter Profile	SL38T 43= SH-55mm
	2	SL38T-PLZ 04		KENET PVC PROFİL / Central Locking PVC Profile	SH-37mm
	1	ASI-NR 01		ÇELİK RAY PROFİLİ / Steel Rail Profile	FW-70

FİTİLLER / GASKETS				
MİKTAR / Unit	KOD / Code	PROFİL ÇİZİMİ / Drawing	PROFİL TANIMI / Description	KESİM ÖLÇÜSÜ / Cutting Dimensions
mt	EP2-02		İÇ CAM FİTİLİ / Inner Glazing Gasket	4x(G1+G2)+2x(G3+G4)
mt	EP38-02		KENET KANAL FİTİLİ / Screw Cover Gasket	2XSH
mt	EP1-01		DIŞ CAM FİTİLİ / Outer Glazing Gasket	4x(G1+G2)+2x(G3+G4)
mt	KF 67-550		FİRÇA FİTİL / Brush Gasket - 5,5 mm	(2xSH)+ CH + (2xCW)
mt	EP38-01		KANAT FİTİLİ / Sash Gasket	(4xSH) + (4xSW)
mt	EP38-05		ÜST KANAT FİTİLİ / Sash Gasket	(4xSW)
mt	EP38-02		KASA KANAL FİTİLİ / Frame Gasket	(2xFH) + FW
mt	EP38-03		SABİT ÇİTA FİTİLİ / Fixed Frame Gasket	2xCW+CH

AKSESUARLAR / ACCESSORIES				
MİKTAR / Pcs	KOD / Code	AKSESUAR ÇİZİMİ / Drawing	AKSESUAR TANIMI / Description	NOT / Note
1 Adet / Pcs	SL38T-KP 04		KENET KAPAĞI ÜST / Interlock Profile Cap Top	SAĞ veya SOL / Right or Left
1 Adet / Pcs	SL38T-KP 05		KENET KAPAĞI ALT / Interlock Profile Cap Bottom	SAĞ veya SOL / Right or Left
2 Adet / Pcs	ASI-STP 06		KANAT STOPER / Sash Stopper	
1 Adet / Pcs	SL38T-SFP 04		ALT HAVA KESİCİ EPDM / Bottom Top Weather Protector	
1 Adet / Pcs	SL38T-SFP 03		ÜST HAVA KESİCİ EPDM / Top Weather Protector	
16 Adet / Pcs	ASI-PB 19		KÖŞE GÖNYESİ / Corner Alignment	
8 Adet / Pcs	ASI-CC 1220		OZEL KOŞE BAĞLANTI / Corner Joint	
4 Adet / Pcs	ASI-PB 1124 ASI-KT 1124		PİMLİ-PRESS BAĞLANTI / Corner Joint Pin	
4 Adet / Pcs	ASI-KT 1105		KÖŞE TAKOZU / Corner Joint	
1 Adet / Pcs	SL38T-MEK1		200 kg KAPASİTELİ KALDIR SÜR MEKANİZMA / Lift & Slide Mechanism	KOL / Handle
4 Adet / Pcs	SL38T-LS1		KALDIR-SÜR SİSTEM İSPANYOLET DESTEĞİ / Lift&Slide Locking Support	
2 Adet / Pcs	SL38T-LS2		KALDIR-SÜR SİSTEM RULMAN DESTEĞİ / Lift&Slide Roller Support	
4 Adet / Pcs	ASI-P 100.1		ORTA KAYIT DIK BAĞLANTI / T Joint	
2 Adet / Pcs	SL38T-KP 03		4'LÜ KANAT ADAPTÖR KAPAĞI / Adapter Cover	
2 Adet / Pcs	SL38T-DB100		KANAT SABİTLEME PARÇASI / Sash Fixed Parts	

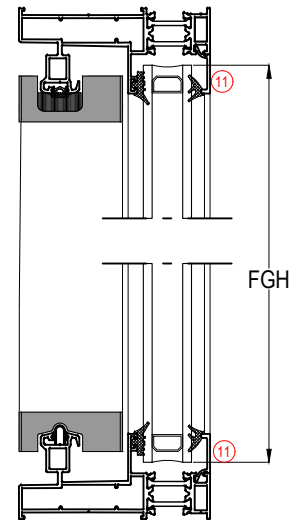

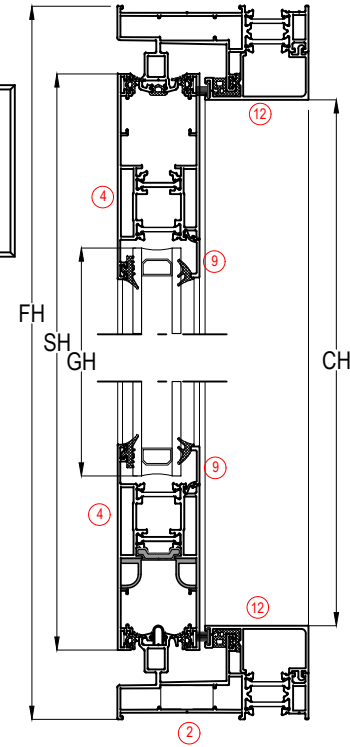
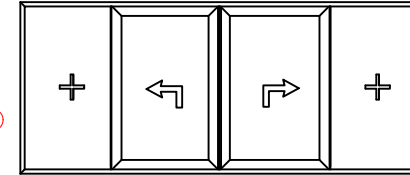
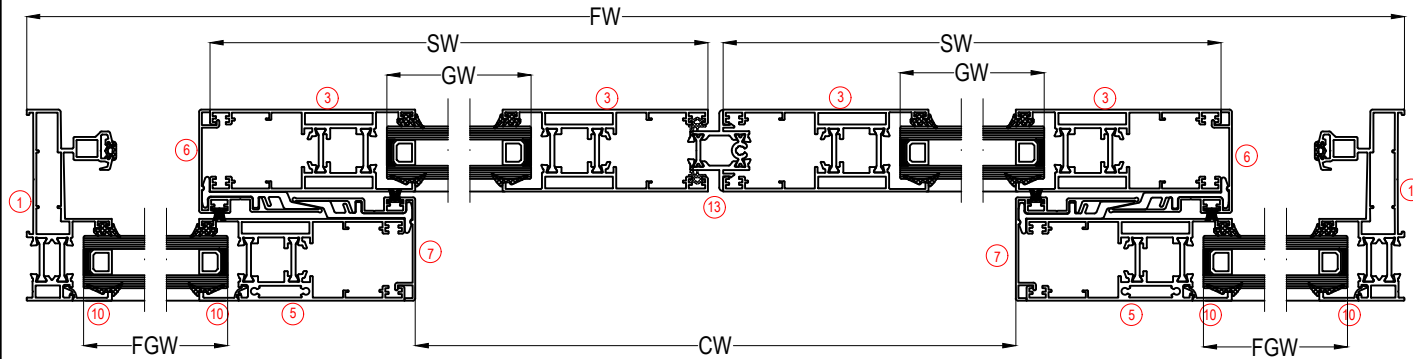

CAM KESİM ÖLÇÜLERİ / GLASS CUTTING SIZES

KOD / Code	TANIMI / Description	KESİM ÖLÇÜSÜ / Cutting Dimensions
GW	HAREKETLİ KANAT CAM GENİŞLİK / Sash Glass Width	GW=SW - 162mm
GH	HAREKETLİ KANAT CAM YÜKSEKLİK / Sash Glass Height	GH=SH - 162mm
FGW	SABİT KISIM CAM GENİŞLİK / Fixed Glass Width	FGW=FW/2 - 106mm
FGH	SABİT KISIM CAM YÜKSEKLİK / Fixed Glass Height	FGH=FH - 52mm

PROFİLLER / PROFILES

NO / Number	ADET / Unit	KOD / Code	PROFİL ÇİZİMİ / Drawing	PROFİL TANIMI / Description	KESİM ÖLÇÜSÜ / Cutting Dimensions
1	2	SL38T 09		DÜŞEY KASA PROFİLİ / Vertical Frame Profile	FH
2	2	SL38T 09		YATAY KASA PROFİLİ / Horizontal Frame Profile	FW
3	4	SL38T16 SL38T17 SL38T12		DÜŞEY KANAT PROFİLİ / Vertical Sash Profile	SH=GH-62,5mm
4	4	SL38T16 SL38T17 SL38T12		YATAY KANAT PROFİLİ / Horizontal Frame Profile	SW=FW/4+70,3mm
5	2	SL38T 16		ORTA KAYIT KANAT PROFİLİ	FH - 42mm
6	2	SL38T42		KENET PROFİLİ / Central Locking Profile	SH - 37mm
7	2	SL38T 42		ORTA KAYIT KENET PROFİLİ / Transom Cover	FH - 42mm
8	4	SL38T 20		KANAT DÜŞEY CAM ÇİTASI (SL38T 16 KANAT İÇİN) / Sash Vertical Glazing Bead	G1=SH-188
9	4	SL38T 20		ANAT YATAY CAM ÇİTASI (SL38T 16 KANAT İÇİN) / Sash Horizontal Glazing Bead	G2=SW-152
10	4	SL38T 20		SABİT DÜŞEY CAM ÇİTASI / Fixed Vertical Glazing Bead	G4=GH - 78mm
11	4	SL38T 20		SABİT YATAY CAM ÇİTASI / Fixed Horizontal Glazing Bead	G3=FW/4-82mm
12	2	SL38T 46		SABİT KASA ALT-ÜST KAPAK PROFİLİ / Top-Bottom Cover Profile	FW/2-40,5 mm
13	1	SL38T43		ADAPTOR PROFİLİ / Adapter Profile	SL38T 43= SH-55mm
	2	SL38T-PLZ 04		KENET PVC PROFİL / Central Locking PVC Profile	SH-37mm
	1	ASI-INR 01		ÇELİK RAY PROFİLİ / Steel Rail Profile	FW-70

FİTİLLER / GASKETS

MİKTAR / Unit	KOD / Code	PROFİL ÇİZİMİ / Drawing	PROFİL TANIMI / Description	KESİM ÖLÇÜSÜ / Cutting Dimensions
mt	EP2-02		İÇ CAM FİTİLİ / Inner Glazing Gasket	4x(G1+G2+G3+G4)
mt	EP38-02		KENET KANAL FİTİLİ / Screw Cover Gasket	4xSH
mt	EP1-01		DIŞ CAM FİTİLİ / Outer Glazing Gasket	4x(G1+G2+G3+G4)
mt	KF 67-550		FİRÇA FİTİL / Brush Gasket - 5,5 mm	(4xSH)+ (2xCW)
mt	EP38-01		KANAT FİTİLİ / Sash Gasket	(2xSH) + (4xSW)
mt	EP38-05		ÜST KANAT FİTİLİ / Sash Gasket	(4xSW)
mt	EP38-02		KASA KANAL FİTİLİ / Frame Gasket	(2XFH) + FW
mt	EP38-03		SABİT ÇİTA FİTİLİ / Fixed Frame Gasket	2xCW

AKSESUARLAR / ACCESSORIES

1 Adet / Pcs	SL38T-KP 04 SAĞ		KENET KAPAĞI ÜST / Interlock Profile Cap Top	
1 Adet / Pcs	SL38T-KP 04 SOL		KENET KAPAĞI ÜST / Interlock Profile Cap Top	
1 Adet / Pcs	SL38T-KP 05 SAĞ		KENET KAPAĞI ALT / Interlock Profile Cap Bottom	
1 Adet / Pcs	SL38T-KP 05 SOL		KENET KAPAĞI ALT / Interlock Profile Cap Bottom	
4 Adet / Pcs	ASI-STP 06		KANAT STOPER / Sash Stopper	
2 Adet / Pcs	SL38T-SFP 04		ALT HAVA KESİCİ EPDM / Bottom Top Weather Protector	
2 Adet / Pcs	SL38T-SFP 03		ÜST HAVA KESİCİ EPDM / Top Weather Protector	
16 Adet / Pcs	ASI-PB 19		KÖŞE GÖNYESİ / Corner Alignment	
8 Adet / Pcs	ASI-CC 1220		OZEL KOŞE BAĞLANTI / Corner Joint	
4 Adet / Pcs	ASI-PB 1124 ASI-KT 1124		PİMLİ-PRESS BAĞLANTI / Corner Joint Pin	
4 Adet / Pcs	ASI-KT 1105		KÖŞE TAKOZU / Corner Joint	
1 Adet / Pcs	SL38T-MEK1D		200 kg KAPASİTELİ KALDIR SÜR MEKANİZMA / Lift & Slide Mechanism	KOL / Handle
8 Adet / Pcs	SL38T-LS1		KALDIR-SÜR SİSTEM İSPANYOLET DESTEĞİ / Lift&Slide Locking Support	
4 Adet / Pcs	SL38T-LS2		KALDIR-SÜR SİSTEM RULMAN DESTEĞİ / Lift&Slide Roller Support	
8 Adet / Pcs	ASI-P 100.1		ORTA KAYIT DIK BAĞLANTI / T Joint	
2 Adet / Pcs	SL38T-KP 03		4'LÜ KANAT ADAPTOR KAPAĞI / Adapter Cover	

